



HYDRAULIC HAMMER OPERATORS MANUAL

GH SERIES HAMMERS

GH06

GH3

GH07

GH4

GH1

GH6

GH2/GH2S/GH2TS

“Use Genuine NPK Parts”

NPK *...attachments;
designed, built
and backed by NPK.*

7550 Independence Drive
Walton Hills, OH 44146-5541
Phone (440) 232-7900
Fax (440) 232-6294

CONTENTS

SAFETY	3
INTRODUCTION.....	5
CARRIER MACHINE COMPATIBILITY	6
HAMMER SPECIFICATIONS	7
STRUCTURE	8
STRUCTURAL DRAWING.....	8
MODELS GH06 – GH3	8
MODELS GH4 – GH6	9
HAMMER SERIAL NUMBER LOCATION	10
SERIAL NUMBER LOCATION (sn1)	10
HYDRAULIC INSTALLATION	11
BACKHOE/EXCAVATOR HAMMER LINES	11
SKID STEER HAMMER LINES	11
HAMMER CONTROL VALVE	11
SKID STEER HAMMER FLOW CONTROL VALVE (OPTIONAL)	12
PREVENTION OF CONTAMINATION.....	13
HYDRAULIC QUICK DISCONNECTS.....	14
MOUNTING INSTALLATION	16
BACKHOES and EXCAVATORS.....	16
SKID STEERS	16
REMOVAL FROM THE CARRIER.....	16
BACKHOES and EXCAVATORS.....	16
REMOVAL FROM THE SKID STEER	17
MOUNTING TO THE CARRIER	17
BACKHOES and EXCAVATORS.....	17
MOUNTING TO THE SKID STEER	17
LUBRICATION	18
GREASING PROCEDURE	18
CORRECT FUNCTION OF GREASING AND GREASE INTERVALS.....	19
CORRECT GREASE FOR HYDRAULIC HAMMERS.....	19
NPK HAMMER GREASE	20
AUTO LUBE SYSTEMS	21
AUTO LUBE GREASE LINE PRE-FILLING.....	22
HAMMER MOUNTED AUTO LUBE GREASE LINE PRE-FILLING.....	25
PRIMING THE GREASE LINE.....	25
LUBRICANT TERMS AND DEFINITIONS.....	27
AUTO LUBE / UNDERWATER PORT IDENTIFICATION.....	29
HIGH HEAT APPLICATION	30
START-UP OPERATION	31
HAMMERS THAT ARE NEW, REBUILT, OR HAVE BEEN INACTIVE	31
BEFORE STARTING THE HAMMER	32
DAILY START-UP PROCEDURE.....	32
OPERATION	33
SAFE OPERATING INSTRUCTIONS.....	33
OPERATING TECHNIQUES & PRECAUTIONS	34
TAMPER PAD OPERATION.....	39

CONTENTS

IMPACT ENERGY TRANSMISSION THROUGH TOOLS	40
IMPACT STRESS WAVES AT THE END OF THE TOOL	41
TOOL BREAKAGE	42
TOOL BREAKAGE DUE TO EXCESSIVE BENDING MOMENT	42
CHARACTERISTICS OF THE BROKEN SECTION	42
TOOL BREAKAGE DUE TO EXCESSIVE WEAR OF THE TOOL HOLDER BUSHINGS	43
CHIPPING IN RETAINING PIN SLOT	45
DEFORMATION OF THE RETAINING PIN SLOT SIDES	45
DEFORMATION OF THE TOOL TIP	46
CHIPPING OF A MOIL POINT TOOL TIP	47
CHIPPING OF A CHISEL TOOL TIP	47
TEMPERATURE RELATED TOOL PROBLEMS	48
TOOL BREAKAGE DUE TO CORROSION	49
TOOL BREAKAGE DUE TO DEFECTIVE MATERIAL	49
ROUTINE INSPECTION AND MAINTENANCE	50
WEEKLY INSPECTION	51
TYPES AND APPLICATIONS OF TOOL	52
STANDARD TOOLS	52
ACCESSORY TOOLS	52
TOOL IDENTIFICATION	53
TOOLS	54
CHANGING THE TOOL	54
MAXIMUM TOOL TO TOOL BUSHING CLEARANCE	55
TOOL INSPECTION	57
CHISEL TOOL SHARPENING	58
STANDARD LENGTH FOR NPK TOOLS	59
TOOL RETAINING PIN INSPECTION	60
TORQUE VALUES FOR HAMMER FASTENERS	61
GAS CHARGE	62
NITROGEN GAS PRESSURE	62
GAS CHARGE ADAPTER	62
GAS CHARGING KIT	63
CHECKING THE GAS PRESSURE	64
CHARGING THE HAMMER	66
DISCHARGING THE GAS PRESSURE	67
STORAGE OF HYDRAULIC HAMMER	68
WARRANTY REGISTRATION FOR NEW UNITS	69
TOOL WARRANTY	70
WARRANTY STATEMENTS	72
NOTES AND RECORDS	76

SAFETY



Safety notices in NPK Instruction Manuals follow ISO and ANSI standards for safety warnings:



DANGER (red) notices indicate an imminently hazardous situation which, if not avoided, **will result in death or serious injury**.



WARNING (orange) notices indicate a potentially hazardous situation which, if not avoided, **could result in death or serious injury**.



CAUTION (yellow) notices indicate a potentially hazardous situation, which, if not avoided, **may result in minor or moderate injury**.



ATTENTION (blue) notices in NPK Instruction Manuals are an NPK standard to alert the reader to situations which, if not avoided, **could result in equipment damage**.

WARNING and BASIC OPERATING INSTRUCTIONS decals are included with each NPK hammer and installation kit. Decals must be installed in the cab, visible to the operator while operating the hammer.

STAY CLEAR, PRESSURE VESSEL, GAS PRESSURE and TOOL SHARPENING decals are installed on all NPK hammer models. Keep them clean and visible. NPK will provide decals free of charge as needed.



1. Operator and Service personnel must read and understand the ***NPK INSTRUCTION MANUAL*** to prevent serious or fatal injury.
2. ***FLYING DEBRIS CAN CAUSE SERIOUS OR FATAL INJURY.***
 - Keep personnel and bystanders clear of hammer while in operation.
 - Do not operate HAMMER without an impact resistant guard between HAMMER and operator. NPK recommends LEXAN® or equivalent material, or steel mesh. Some carrier manufacturers offer demolition guards for their machine. Check with the carrier manufacturer for availability. If not available, please call NPK.
3. Do not hardface or sharpen the tool point with a cutting torch. Excessive heat from torching or welding can cause embrittlement, breakage, and flying pieces. Resharpener by milling or grinding only, using sufficient coolant.

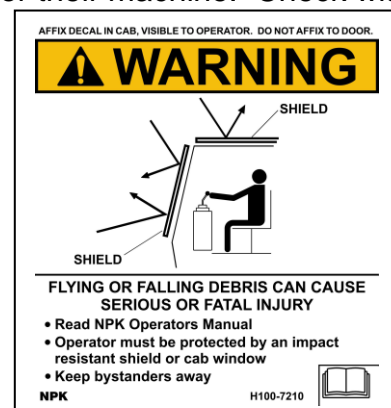

SAFETY

CAUTION

4. Fully extend the tool while charging the HAMMER with nitrogen gas. Be sure that the retaining pin is installed. **STAY CLEAR OF TOOL POINT WHILE CHARGING.**
5. Do not disassemble a HAMMER before discharging the hammer gas pre-charge.
6. **USE NITROGEN GAS ONLY!** Store and handle nitrogen tanks per OSHA regulations.
7. Avoid high pressure fluids. Escaping fluid under pressure can penetrate the skin causing serious injury. Relieve pressure before disconnecting hydraulic or other lines.
8. Operate HAMMER from operator's seat only.
9. Match HAMMER size to carrier according to NPK recommendations. The carrier must be stable during hammer operation and during transport.
See CARRIER MACHINE COMPATIBILITY section of the NPK instruction manual.
10. Do not make any alterations to the TOOL without authorization from NPK Engineering.
11. Use proper lifting equipment and tools when handling or servicing the HAMMER.
12. Wear ear protection and safety glasses when operating the hammer. Consult OSHA/MSHA regulations when applicable.
13. Beware of flying metal pieces when driving Boom Pins.
14. If modifications are to be made, **do not alter the HAMMER without authorization from NPK Engineering!**
15. Use only genuine NPK replacement parts. NPK specifically disclaims any responsibility for any damage or injury that results from the use of any tool or parts not sold or approved by NPK.

For further safety information, consult the AEM Hydraulic Mounted Breakers Safety Manual, AEM form MB-140 (NPK P/N H050-9600), which is furnished with every NPK hammer. To request an additional copy, please contact NPK at 440-232-7900 or Internet at www.npkce.com.

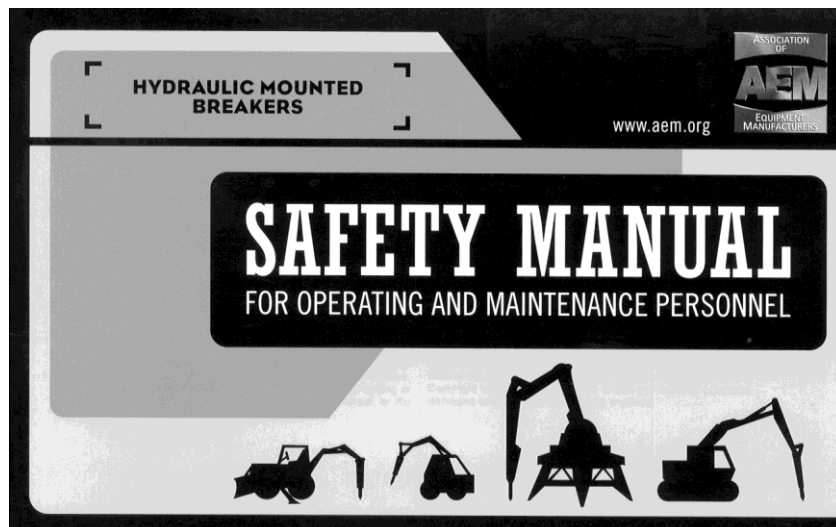

INTRODUCTION

NPK is a leading manufacturer of HYDRAULIC HAMMERS and has the most complete product line available anywhere. The success of NPK is due to our commitment to quality, dependability, and long life. The HYDRAULIC HAMMER has many unique designed features, and it is a company philosophy that the NPK HYDRAULIC HAMMER can be brought to "like new" condition long after competitive products are scrapped. You can feel confident that you have purchased the best value available.

This comprehensive operator's manual contains instructions for operating and maintaining NPK HYDRAULIC HAMMERS. This manual includes helpful information for obtaining the full potential and efficiency from NPK HYDRAULIC HAMMERS. Please read this manual thoroughly to understand the NPK HAMMER and its operating principles before using it.

For additional information or help with any problem encountered, please contact your NPK authorized dealer.

Whenever repair or replacement of component parts is required, only NPK parts should be used. NPK is not responsible for failures resulting from substitution of parts not sold or approved by NPK.

This manual will also assist NPK Dealers and Customers to obtain the longest possible life from the NPK Demolition Tools.

Customers can use this manual to take corrective action when tool breakage occurs. Dealers can use this manual to determine if tool breakage can be claimed under warranty.

Refer to the NPK Demolition Tool Warranty Statement found later in this manual for the specifics of the warranty coverage.

CARRIER MACHINE COMPATIBILITY

These carrier weight ranges are intended as a guideline only. Other factors, such as stick length, counterweights, undercarriage, etc., must be taken into consideration.



Mounting a HAMMER that is too heavy for the carrier machine can be dangerous and damage the machine. Verify carrier stability with hammer before transport or operation.

Mounting a HAMMER that is too small for the carrier machine can damage the HAMMER, cause tool breakage and void Warranties. Please consult NPK Engineering for specific detailed information.

CARRIER WEIGHT lbs. (*metric tons*)

HAMMER MODEL	MOUNTING STYLE	RECOMMENDED RANGE	
		lbs.	(<i>metric tons</i>)
GH06	Excavator	2,200 - 4,400	(1 - 2)
	Skid Steer	2,400 - 3,500	(1.1 - 1.6)
GH07	Excavator	2,800 - 5,500	(1.3 - 2.5)
	Skid Steer	3,000 - 5,500	(1.4 - 2.5)
GH1	Excavator	5,400 - 9,000	(2.5 - 4.1)
	Skid Steer	5,000 - 7,500	(2.3 - 3.4)
GH2/GH2S/ GH2TS	Excavator	6,600 - 12,000	(3 - 5.4)
	Skid Steer	6,000 - 9,000	(2.7 - 4.1)
GH3	Excavator	8,800 - 15,000	(4 - 6.8)
	Skid Steer	8,000 - 14,000	(3.6 - 6.4)
GH4	Excavator	13,000 - 22,000	(5.9 - 10)
GH6	Excavator	22,000 - 31,000	(10 - 14.1)

**Specifications are subject to change without notice.*

HAMMER SPECIFICATIONS

HAMMER MODEL	IMPACT ENERGY CLASS		FREQUENCY	MOUNTING STYLE	WORKING WEIGHT		TOOL			
							DIA.		WORKING LENGTH	
	ft lb	(J)			bpm	lbs.	(kg)	in.	(mm)	in.
GH06	150	205	480 - 1,200	Excavator	500	(225)	1.65	(42)	11.8	(300)
				Skid Steer	235	(107)				
GH07	200	270	500 - 1,200	Excavator	270	(125)	1.85	(47)	12.4	(316)
				Skid Steer	550	(250)				
GH1	350	475	550 - 1,100	Excavator	450	(205)	2.24	(57)	14.0	(356)
				Skid Steer	750	(340)				
GH2/GH2S/ GH2TS	500	680	500 - 1,300	Excavator	525	(240)	2.60	(66)	15.1	(384)
				Skid Steer	800	(365)				
GH3	750	1,015	500 - 1,150	Excavator	800	(365)	2.99	(76)	16.5	(419)
				Skid Steer	1,075	(490)				
GH4	1,300	1,765	400 - 1,050	Excavator	1,250	(570)	3.39	(86)	18.5	(469)
GH6	2,000	2,710	460 - 800	Excavator	2,500	(1,135)	4.17	(106)	19.7	(500)

HAMMER MODEL	OIL FLOW		HYDRAULIC OPERATING PRESSURE ¹		MINIMUM CIRCUIT RELIEF ²	
	gpm	(lpm)	psi	(bar)	psi	(bar)
GH06	2.5 - 7	(10 - 25)	1,650	(115)	2,150	(150)
GH07	4 - 9	(15 - 35)	1,500	(105)	2,000	(140)
GH1	7 - 13	(25 - 50)	1,750	(120)	2,250	(155)
GH2/GH2S/ GH2TS	7 - 17	(25 - 65)	2,250	(160)	2,750	(190)
GH3	12 - 26	(45 - 100)	1,900	(130)	2,400	(165)
GH4	13 - 32	(50 - 120)	2,200	(150)	2,700	(185)
GH6	24 - 40	(90 - 150)	2,400	(165)	2,900	(200)

NITROGEN GAS PRE-CHARGE

HAMMER MODEL	AT AMBIENT TEMPERATURE (cold before operating)		AT OPERATING TEMPERATURE (hot, after 1 to 2 hrs. operation)	
	psi	(bar)	psi	(bar)
GH06	350	(24)	405	(28)
GH07	350	(24)	405	(28)
GH1	350	(24)	405	(28)
GH2/GH2S/ GH2TS	350	(24)	405	(28)
GH3	350	(24)	405	(28)
GH4	375	(26)	435	(30)
GH6	390	(27)	450	(31)

*Specifications subject to change without notice.

NOTES:

- Hydraulic operating pressure maximum is inlet pressure at the hammer with the oil at operating temperature and with the gas charge set at the hot operating pressure. See "CHECKING THE HYDRAULIC PRESSURES" section in this manual.
- Circuit relief pressure is at least 500 psi (35 bar) above hammer operating pressure. Above 1,000 psi (70 bar) for machines with dual stage relief.
- Cold gas charge is the initial set with the hammer at ambient temperature.
- Hot gas charge is checked after 1 to 2 hours of running and with a system oil temperature of 140° to 180°F (60° to 80° C). This is the preferred check.
- Gas pressures listed are the maximum allowed. Use tolerance of minus 25 psi (2 bar).

STRUCTURE

STRUCTURAL DRAWING

MODELS GH06 – GH3

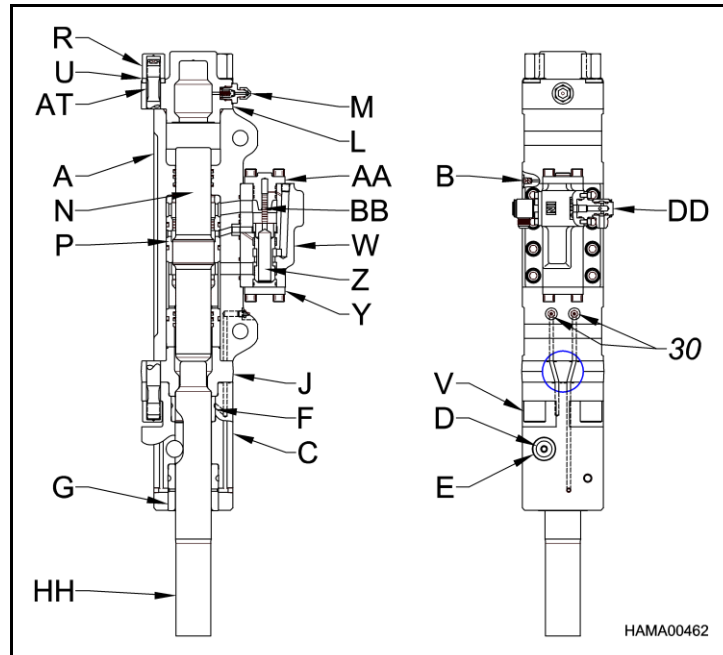

30	GREASE FITTING
A	MAIN BODY
AA	PLUNGER BUSHING
B	DRAIN PLUG
BB	PLUNGER
C	TOOL HOLDER
D	RETAINING PIN
DD	SWIVEL ELBOW
E	RETAINING RING
F	UPPER TOOL BUSHING (*GH2, GH2TS, GH3 only)
G	LOWER TOOL BUSHING
HH	TOOL
J	IMPACT RING (SPACER SECTION)
L	GAS HEAD
M	CHARGE VALVE
N	PISTON
P	MAIN BODY SLEEVE (B)
R	TOP NUT
U	WASHER
V	BOTTOM NUT
W	VALVE BODY
Y	VALVE BOTTOM CAP
Z	VALVE SPOOL

*GH2 assembly number 132501-16 only

STRUCTURE

STRUCTURAL DRAWING

MODELS GH4 – GH6

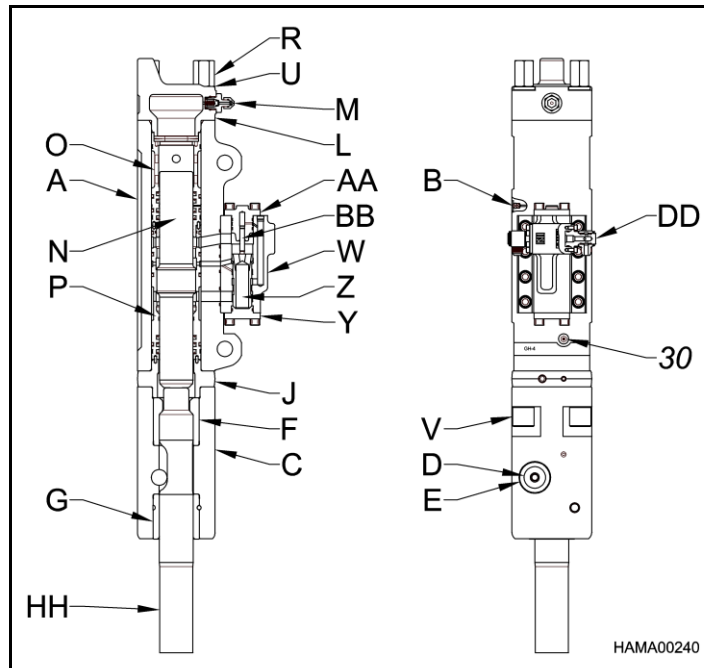

30	GREASE FITTING
A	MAIN BODY
AA	PLUNGER BUSHING
AT	COLLAR
B	DRAIN PLUG
BB	PLUNGER
C	TOOL HOLDER
D	RETAINING PIN
DD	SWIVEL ELBOW
E	RETAINING RING
F	UPPER TOOL BUSHING
G	LOWER TOOL BUSHING
HH	TOOL
J	IMPACT RING
L	GAS HEAD
M	CHARGE VALVE
N	PISTON
O	MAIN BODY SLEEVE (A)
P	MAIN BODY SLEEVE (B)
R	TOP NUT
U	WASHER
V	BOTTOM NUT
W	VALVE BODY
Y	VALVE BOTTOM CAP
Z	VALVE SPOOL

HAMMER SERIAL NUMBER LOCATION

SERIAL NUMBER LOCATION (sn1)

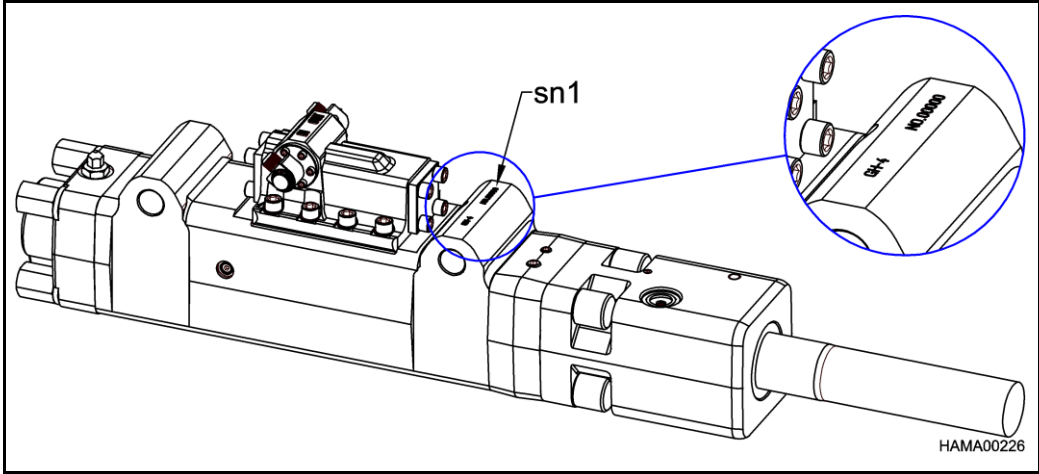

HYDRAULIC INSTALLATION

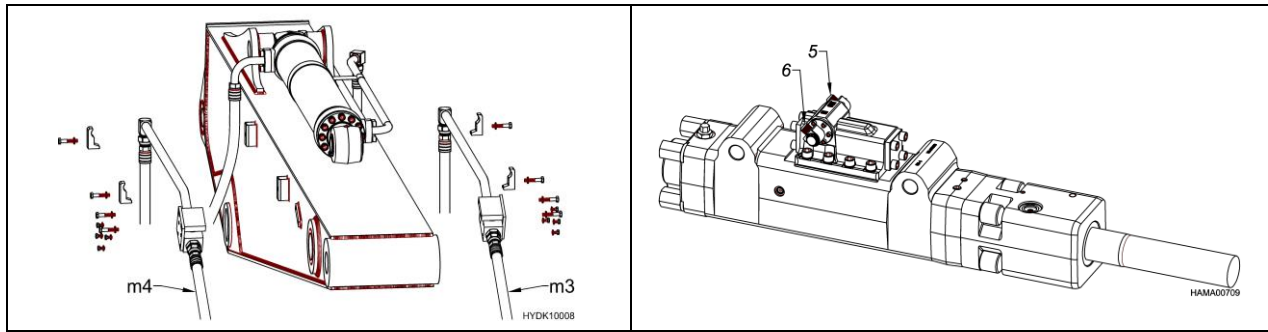

BACKHOE/EXCAVATOR HAMMER LINES

Typically, the pressure line should be arranged on the left side of the boom and routed to the hammer “IN” port (6) and the return line is routed from the hammer “OUT” port (5) on the right side. Flow to the hammer is controlled from the carrier’s auxiliary valve or from an NPK supplied flow valve. Hydraulic oil is generally routed back to the tank thru the carrier’s oil cooler and filter.

SKID STEER HAMMER LINES

Flow to the hammer (m3) is directed from an auxiliary valve on the skid steer. NPK hammer ports are marked “IN” and “OUT”. Return oil (m4) is routed back to tank through the skid steer return hydraulic circuit.

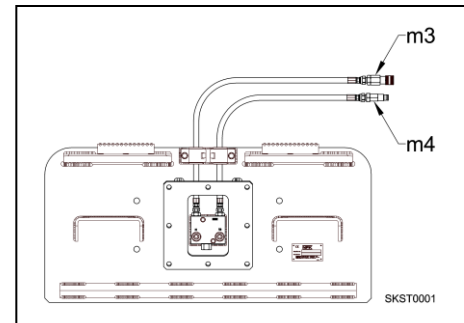

HAMMER CONTROL VALVE

There are two general types of control systems depending on the carrier model:

1. CONTROL SYSTEM USING THE CARRIER AUXILIARY OR SPARE VALVE SECTION.

This type of installation utilizes an existing carrier valve. Any additional parts, such as a mechanical linkage, hydraulic pilot actuators, flow control valves, etc., are supplied by the hydraulic kit supplier. **NOTE:** Special pressure control valves are not required. The NPK hammer operating pressure is self-regulating.

2. CONTROL SYSTEM USING THE NPK FLOW VALVE (MULTIVALVE).

For carriers not equipped with a suitable auxiliary or spare valve section, NPK can provide a solenoid operated, priority flow control valve to operate the NPK hammer. The NPK multivalve is specifically designed for the operation of boom mounted attachments.

HYDRAULIC INSTALLATION

SKID STEER HAMMER FLOW CONTROL VALVE (OPTIONAL)

On skid steers where auxiliary flow is excessive for the NPK hammer model, an NPK flow control valve (ma3) is recommended.

NOTE: *Be sure that the pressure (m3) and return (m4) lines are properly routed.*

Inlet pressure connects to port "P" on the NPK flow control valve. Regulated flow from valve port "H" (m5) connects to the "IN" port on the NPK hammer. The "OUT" port on the hammer connects to port "T2" (m6) on the flow control valve. Port "T1" connects to the return line (m4) on the skid steer.

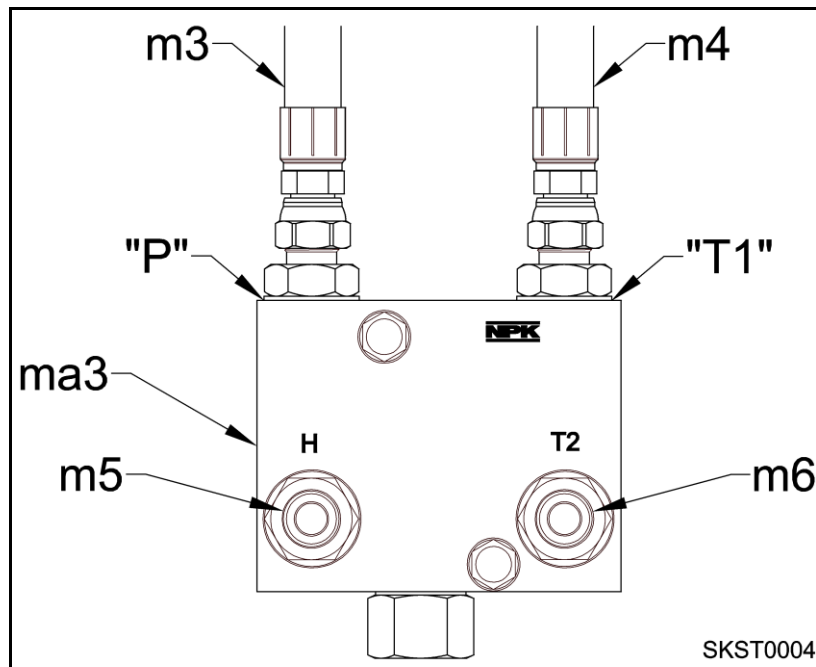

HYDRAULIC INSTALLATION

ATTENTION PREVENTION OF CONTAMINATION

1. A hydraulic hammer is harder on oil than using a bucket, so the oil is apt to deteriorate and breakdown sooner. Neglect of the oil system can not only damage the hydraulic hammer but also cause problems in the carrier which could result in damaged components. Care should be taken to check for contamination of the oil and to change it if it is found contaminated. ***Oil sampling at regular intervals is highly recommended.***
 - ❖ When the hydraulic oil shows low viscosity and bubbles, this indicates that the oil is deteriorated. If the oil is dark brown and gives off an offensive odor, it is severely deteriorated. ***Change the oil immediately!***
 - ❖ When the oil is clouded, or the oil filter has become clogged, it indicates that the oil is contaminated. ***Change the oil immediately!***
 - ❖ To change the contaminated hydraulic oil, drain the hydraulic system completely and clean components. Do not mix new oil with the old.
2. Do not allow any contamination to mix with the oil. Take special care in preventing contamination from entering the hydraulic system through the hose or tube connection when changing the hydraulic hammer with the bucket.
3. Low oil level will cause heat build-up, resulting in deterioration of the oil. Also, it may cause cavitation due to air mixing with the oil, leading to a damaged hydraulic hammer and carrier components. Keep the oil at the proper level at all times.
4. Do not use the hydraulic hammer at an operating temperature higher than 180°F (80°C). The proper operating oil temperature range is between 120°F (50°C) and 180°F (80°C). Since contaminated cooler fins causes reduced efficiency of the cooler, keep the cooler fins clean at all times. Check the hydraulic oil cooling system to be sure it is working effectively. The use of a heat gun is the best way to evaluate if the cooler is working properly.
5. Water in the hydraulic oil will lead to damage of the hydraulic hammer and carrier. Drain off water and foreign matter from the hydraulic tank at specified intervals. When out of service, the hydraulic hammer should be stored indoors.

CHANGING THE FILTER ELEMENT AND HYDRAULIC OIL

Change the filter element and hydraulic oil at the intervals described in the operation manual of the skid steer or excavator, when using a hydraulic implement. Another method is to set up an oil sampling schedule and change accordingly.

HYDRAULIC INSTALLATION

HYDRAULIC QUICK DISCONNECTS

NPK recommends against the use of non-NPK quick disconnects on hydraulic circuits operating NPK Products.

1. The hydraulic pulsations caused by hydraulic hammer operating can cause internal pieces of non-NPK quick disconnects (32) to disintegrate. These pieces would migrate into the hammer, causing damage.
2. If hydraulic quick disconnects are used, they should be capped when the hammer is removed from the carrier to keep them clean. Contamination can get into the hydraulic quick disconnect and can be flushed into the hammer and/or the hydraulic system when re-connected. This, again, can cause damage.
3. Most quick disconnects create a restriction in the circuit. NPK Hammers are not backpressure sensitive, but restrictions cause unnecessary heating of the oil. Also, the pressure required to operate the hammer, plus the restriction in the disconnects may push an older, low pressure, carrier machine to the limit of its hydraulic system. This would interfere with proper hammer operation. **However, the NPK approved quick disconnects are properly sized so that the hammer operation is not affected.**

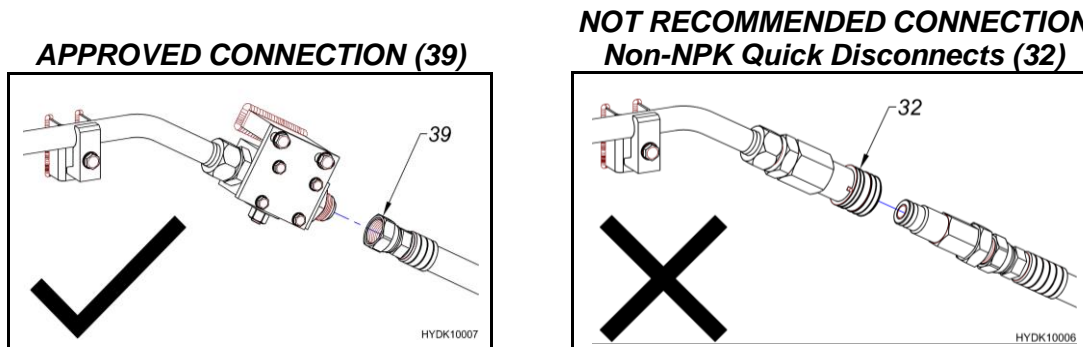

**NPK APPROVED CONNECTION QUICK DISCONNECTS
CONTACT YOUR NPK DEALER FOR ADDITIONAL INFORMATION ABOUT
NPK QUICK DISCONNECTS**

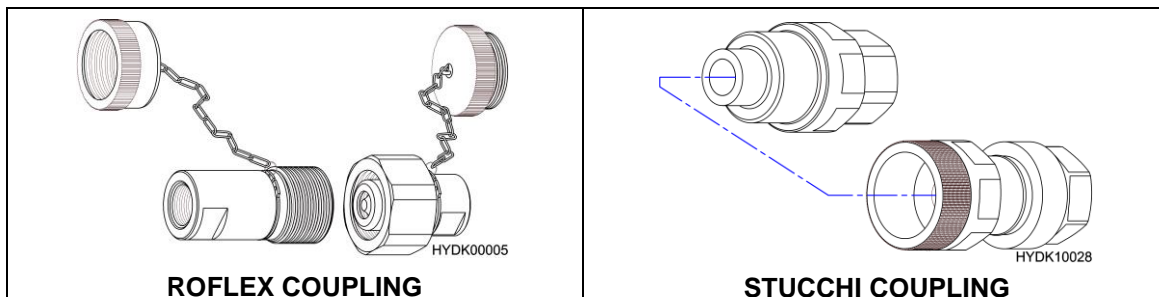

HYDRAULIC INSTALLATION

HYDRAULIC QUICK DISCONNECTS

If hydraulic quick disconnects are used with the NPK Hammer, it is recommended that the following precautions be followed:

1. Periodic inspection of both male (DXm) and female (DXf) ends is recommended to ensure the couplers are in good working condition. Failure to inspect couplers may result in pieces from a damaged or failed coupler to migrate into the hammer or parts of the coupler returned to the machine.
2. Check for dirt, dust, and debris on both couplers before coupling.
3. Be sure that the couplers are completely seated together (38).
4. When replacing couplers, be sure that couplers are replaced as a set, male and female. Do not use one new end and one used end.

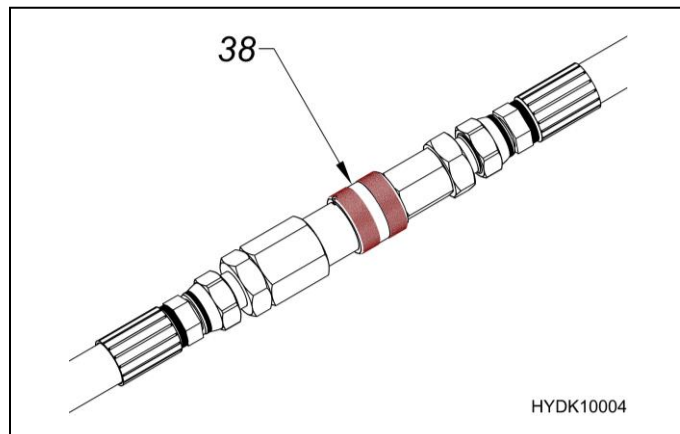
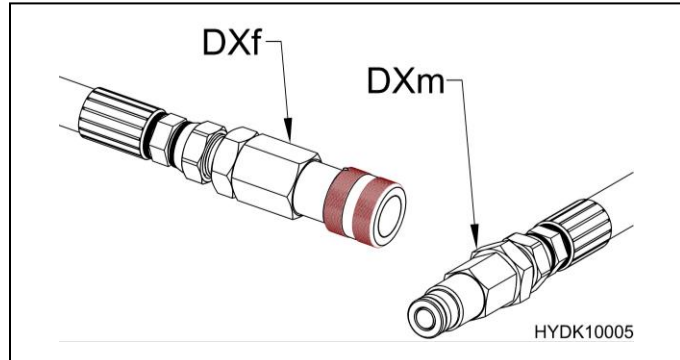

MOUNTING INSTALLATION

NPK Mounting Installation Kits include the parts required to adapt the NPK HYDRAULIC HAMMER to the carrier. NPK mounting kits include the hammer mounting bracket, mounting pins (optional), flow control valve (optional), and hoses to connect to the carrier hydraulic system (optional).

BACKHOES and EXCAVATORS

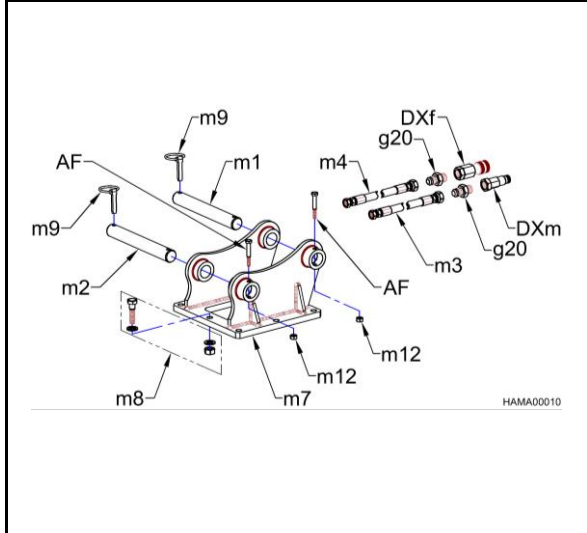

AF	HEX HEAD CAP SCREW (if required)
DXf	FEMALE QUICK DISCONNECT (if required)
DXm	MALE QUICK DISCONNECT (if required)
g20	MALE ADAPTER (if required)
m1	STICK PIN (if required)
m2	LINK PIN (if required)
m3	WHIP HOSE (pressure)
m4	WHIP HOSE (return)
m7	TOP BRACKET
m8	HAMMER BOLT PACKAGE
m9	KLIK PIN (if required)
m12	HEX NUT (if required)

SKID STEERS

NPK Mounting Installation Kits for skid steers include parts required to adapt the NPK HYDRAULIC HAMMER to the carrier. NPK mounting kits include the hammer mounting bracket (m7), and hoses (m3 and m4) to connect to the carrier hydraulic system. The flow control valve (ma3) is optional.

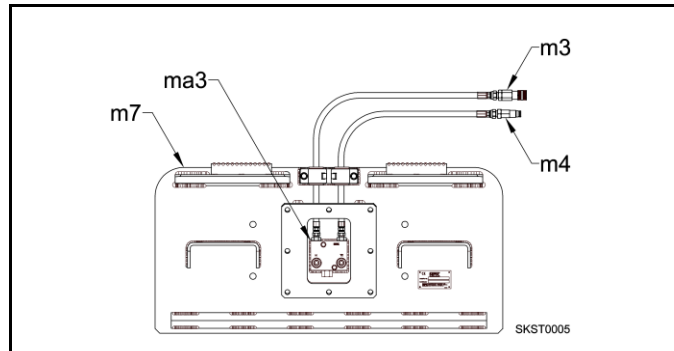

REMOVAL FROM THE CARRIER

BACKHOES and EXCAVATORS

1. Close pressure and return line shut-off valves (k4) if available.
2. Disconnect hydraulic hoses (m3 and m4) before laying the hammer down.
3. Cap the pressure and return lines on the carrier and connect the hammer whip hoses to the hammer bracket.
4. Position the hammer (DR) horizontal on wood blocks (t20) and remove stick (m1) and link (m2) pins.

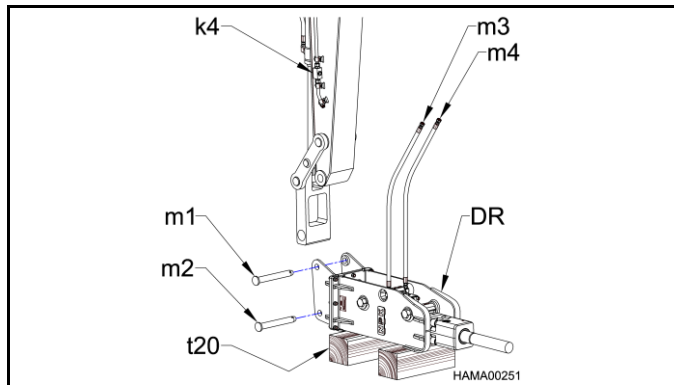

MOUNTING INSTALLATION

REMOVAL FROM THE SKID STEER

1. Position the hammer (DR) horizontally onto the ground or wood blocks (t20) as shown.
2. Disconnect both inlet and outlet hoses.
3. Unlatch the mechanism holding the hammer bracket to the carrier's coupler plate. (Consult the machine manufacturer's operator / instruction manual for this procedure.)

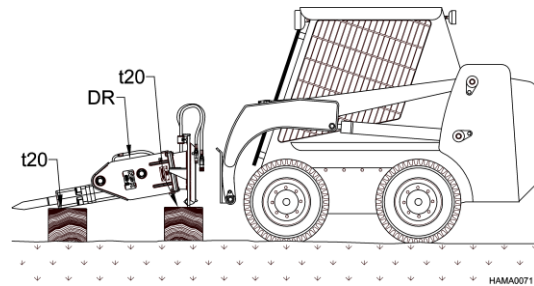

ATTENTION

The tool end of the hammer should be set lower than the head end to prevent moisture from entering the hammer through the tool area.

MOUNTING TO THE CARRIER BACKHOES and EXCAVATORS

1. Place the hammer assembly (DR) horizontally on wood blocks (t20) as shown.
2. Align the stick pin bore (m26). Install the stick pin. Then align the link pin bore (m25).
3. Connect the pressure side hose (m3) and the return side hose (m4).
4. Open the shut-off valves (k4) if available.

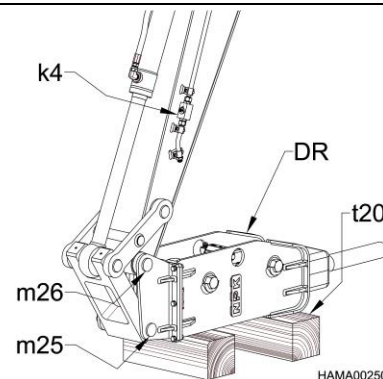

MOUNTING TO THE SKID STEER

1. Place the hammer (DR) horizontally onto wood blocks (t20) as shown.
2. Align the carrier's coupler plate with the hammer bracket. Couple the two per the machine manufacturer recommendations.
3. Connect the hoses.

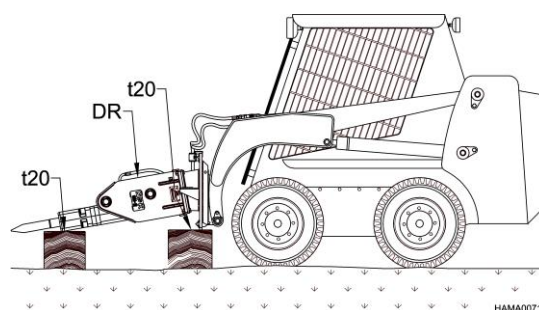

Consult the skid steer manufacturer's operators manual to review the mounting and removal process!

ATTENTION

The hydraulic lines must be handled carefully and sealed to prevent contamination from entering the hammer or the carrier's hydraulic system.

LUBRICATION

GREASING PROCEDURE

Manual greasing for hammers without an Auto Lube System.

1. Place the hammer in a vertical position, applying enough downforce to push the tool up into the hammer.

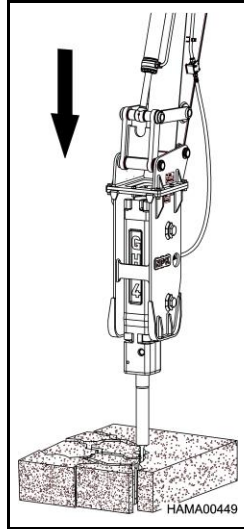

2. Turn the machine off.
3. Grease the hammer until grease begins to come out around the tool (HH) and lower bushing (see arrow).

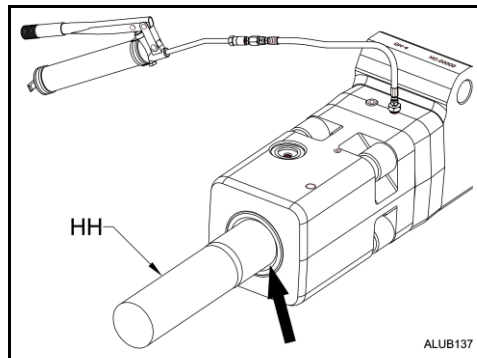

4. Grease hammer at least once an hour. See **“CORRECT FUNCTION OF GREASING AND GREASE INTERVALS”** for a more exact greasing procedure.

NOTE: USE A GOOD QUALITY EP #2 LITHIUM BASED GREASE WITH WEAR INHIBITING ADDITIVES, SEE PAGES 19 through 20.

LUBRICATION

CORRECT FUNCTION OF GREASING AND GREASE INTERVALS

Proper hammer maintenance requires a sufficient supply of the correct grease to the tool (chisel). It is recommended that an NPK AUTO LUBE SYSTEM be used.

FUNCTION OF GREASING

To properly grease, the tool must be pressed against a hard surface until it stops up inside the hammer. This prevents grease from entering piston impact area and ensures proper distribution of grease between the tool and tool bushings.

GREASE INTERVALS

If the hammer is not connected to an Auto Lube System the unit must be greased at regular intervals to get the best life from the tool and tool bushings. There are two ways to determine grease intervals:

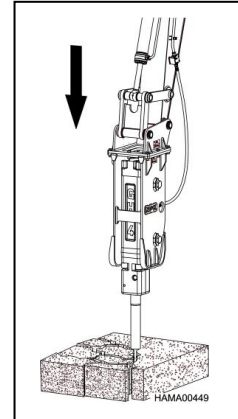

First, grease the hammer at the beginning of the job until grease comes out between the tool and the lower tool bushing. Run the hammer until the shank of the tool starts to look dry. This determines the time interval for the greasing of this particular hammer on this particular job. Typically, this is 1 to 4 hours. Also, note the amount of grease needed to re-grease the tool. This gives you the amount of grease and how often it must be applied. An example would be that a particular hammer, on a particular job, requires half a tube of grease every 3 hours. This would be the greasing schedule you would set up. If this hammer was moved to another job, another grease schedule may have to be determined.

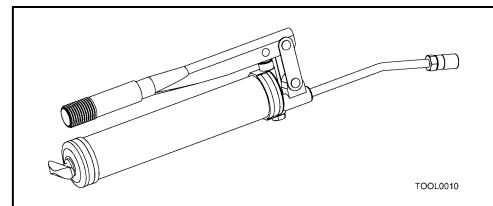

Second, if you can't control the grease schedule, such as rental units, then have the operator grease the hammer once every hour of hammer operation. Again, grease the hammer until grease comes out between the tool and tool bushing. This is usually more often than required but is far cheaper than replacing prematurely worn tools and tool bushings.

CORRECT GREASE FOR HYDRAULIC HAMMERS

The type of grease used is very important. NPK recommends a lithium soap base EP (Extreme Pressure) NLGI #2 Grease, with Moly (Molybdenum Disulfide) or other surface protecting additives. A high drop point 350°F (177°C) grease is desirable.

There are many manufacturers of grease that meet NPK's recommendations. NPK does not endorse any one brand as being superior to another. If you or your customers question a brand to be used, please call the NPK Service Department at 440-232-7900.

LUBRICATION

CORRECT GREASE FOR HYDRAULIC HAMMERS

NPK HAMMER GREASE

NPK now offers hammer grease specially formulated to meet severe job requirements. The grease is available in two different temperature ranges - 350°F (177°C), 500°F (260°C).

“Universal Plus” and “Super Duty” are lithium soap-based products that resist washout and contain NPK-10 additive for surface protection in friction affected areas.

“Chisel Paste” is an aluminum complex soap base with 12% graphite and copper additives for extreme operating conditions.

350°	500°	500°
NPK UNIVERSAL PLUS LITHIUM PLUS EP2 GREASE	NPK SUPER DUTY EP2 GREASE WATER RESISTANT	NPK CHISEL PASTE EP2 GREASE EXTREME TEMP. WATER RESISTANT

ALUB131

UNIVERSAL PLUS 350 deg	NPK PART NUMBER
14 oz. (.397 kg) CARTRIDGE	G000-1010
120 lb. (54 kg) KEG	G000-1020
35 lb. (16 kg) PAIL	G000-1030
400 lb. (181 kg) DRUM	G000-1040

SUPER DUTY 500 deg	NPK PART NUMBER
14 oz. (.397 kg) CARTRIDGE	G000-1011
120 lb. (54 kg) KEG	G000-1021
35 lb. (16 kg) PAIL	G000-1031
400 lb. (181 kg) DRUM	G000-1041

CHISEL PASTE 500 deg	NPK PART NUMBER
14 oz. (.397 kg) CARTRIDGE	G000-1050
*14 oz. (.397 kg) CARTRIDGE	G025-1050
35 lb. (16 kg) PAIL	G000-1060
400 lb. (181 kg) DRUM	G000-1070

*Hammer Mounted Auto Lube only

LUBRICATION

AUTO LUBE SYSTEMS

An automatic greasing system is recommended to reduce hammer tool and bushings wear. NPK offers two types of Auto Lube Systems:

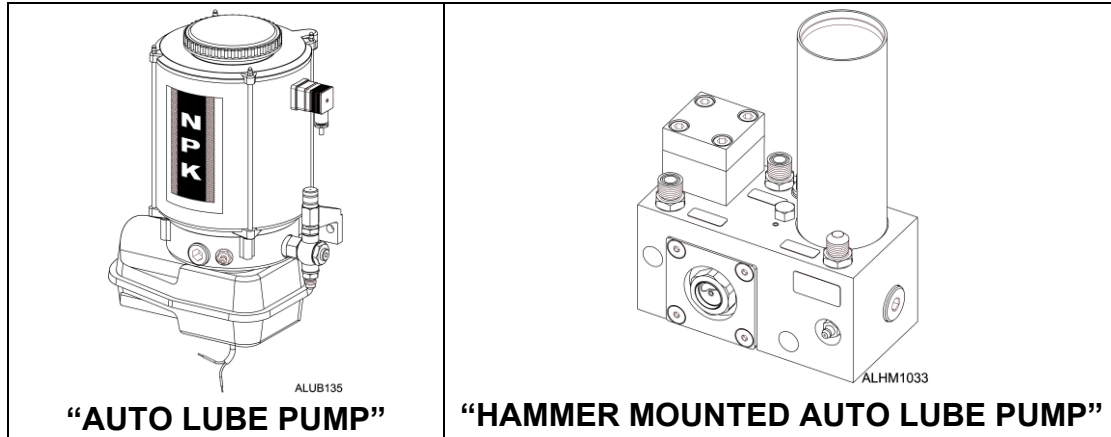

The NPK Auto Lube Systems are designed to automatically provide a continuous supply of grease to the hammer tool and tool bushing, increasing tool and tool bushing life by reducing wear. The Auto Lube pumps are capable of pumping EP2 grease in cold weather. The pump output is adjustable according to the replacements of the hammer model and to compensate for tool bushing wear.

NPK GH Series hammer models have a connection port (26) for an automatic greasing system. Refer to the NPK Auto Lube Instruction Manuals for details.

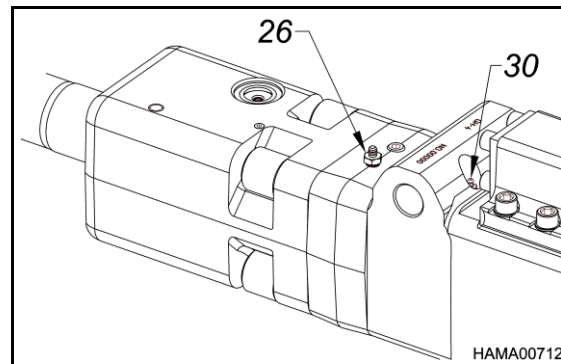

If an Auto Lube System is not used, you can grease the unit manually through the grease fitting (30).

LUBRICATION

AUTO LUBE GREASE LINE PRE-FILLING

It is **mandatory** that the supply line from the Auto Lube main pump to the connection on the hammer is primed with grease before it is used. **Failure** to do this will result in no grease being administered to the hammer tool for **two to three** hours. This can and will result in severe galling of the tool and tool bushing.

PRIMING THE GREASE LINE

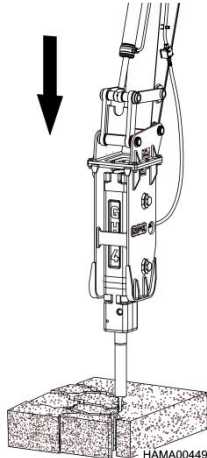
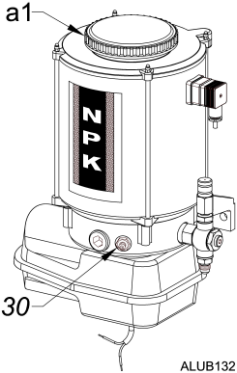
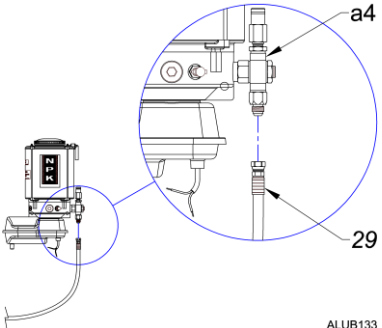
<p>1. Place the hammer in a vertical position, applying enough down force to push the tool up into the hammer.</p>	 <p>HAMA00449</p>
<p>2. Turn the excavator/backhoe off.</p>	
<p>3. Fill the NPK Auto Lube pump reservoir with a power greaser through the fill fitting (30) on the side of the pump or from the top by removing the fill cover (a1). Use a premium quality grade EP#2, high temperature grease with wear inhibiting additive. (See “CORRECT GREASE FOR HYDRAULIC HAMMERS”.)</p>	 <p>ALUB132</p>
<p>4. Disconnect the grease line (29) from the Auto Lube main pump cartridge (a4).</p>	 <p>ALUB133</p>

LUBRICATION

AUTO LUBE GREASE LINE PRE-FILLING

5. Install NPK part number G100-8050, hose fill adapter (a13), onto the #6 JIC female end of the grease line (29) previously removed.

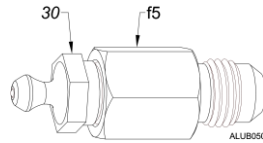
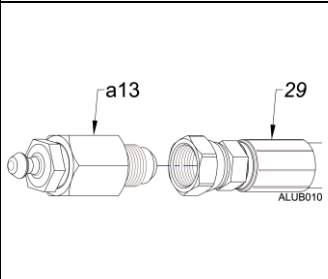

ITEM	PART NUMBER	DESCRIPTION
30	B160-4010	Grease Fitting - 1/4" NPT male
f5	K301-6620	Male x Female Adapter - #6 JIC male x 1/4" NPT female

6. Remove the grease line (29) at the hammer assembly (KK).

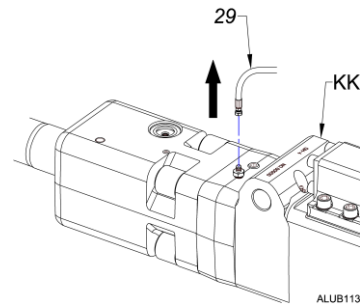

7. Attach a grease gun (t37) or power greaser to the grease line (29) leading to the hammer.

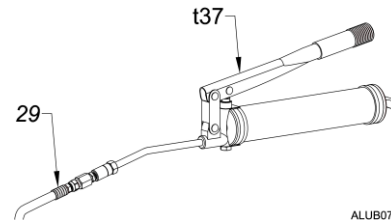

8. Pump grease through the grease line (29) until a steady stream of grease (28) is realized at the opposite (hammer) end.

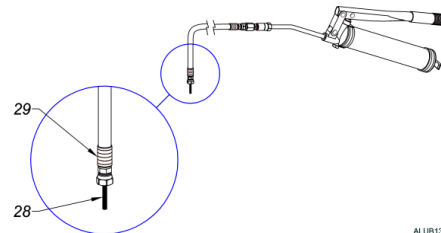

9. Re-attach the grease line (29) to the hammer assembly (KK).

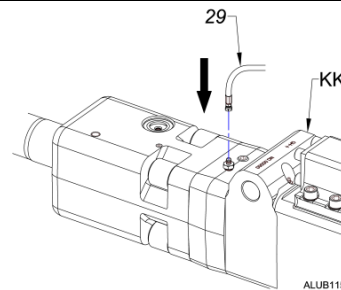

LUBRICATION

AUTO LUBE GREASE LINE PRE-FILLING

10. Pump twenty more shots of grease, using a grease gun or power greaser, into the grease line (29). This will prime the hammer tool cavity and pre-lube the tool (HH). Look for grease coming out around the tool at the tool bushing (see arrow).

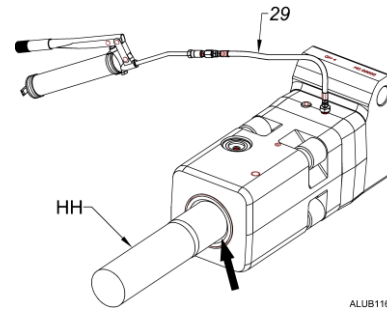

ALUB116

11. Remove the hose fill adapter (a13) and re-connect the grease line (29) to the Auto Lube pump (FZ).

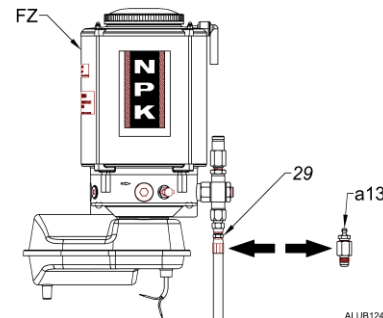

ALUB124

NOTE: If the Auto Lube unit has run out of grease, the above procedure should be used to purge all air out of the grease line before using the hammer. Failure to do this will result in an intermittent supply of grease to the hammer.

LUBRICATION

HAMMER MOUNTED AUTO LUBE GREASE LINE PRE-FILLING

It is **mandatory** that the supply line from the Auto Lube main pump to the connection on the hammer is primed with grease before it is used. **Failure** to do this will result in no grease being administered to the hammer tool for two to three hours. This can and will result in severe galling of the tool and tool bushing.

PRIMING THE GREASE LINE

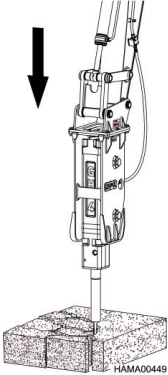
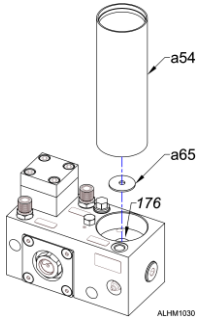
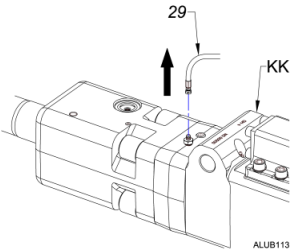
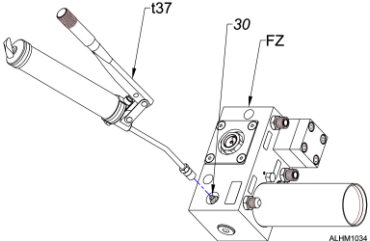
<p>1. Place the hammer in a vertical position, applying enough down force to push the tool up into the hammer.</p>	
<p>2. Turn the excavator/backhoe off.</p>	
<p>3. Make sure there is a full grease cartridge (a54) installed in the Hammer Mounted Auto Lube assembly. Ensure that the flat seal (a65) in the lubrication passage (176) is not damaged. Use a premium quality grade EP#2, high temperature grease with wear inhibiting additive. (See “CORRECT GREASE FOR HYDRAULIC HAMMERS”.)</p>	
<p>4. Disconnect the grease line (29) at the hammer assembly (KK).</p>	
<p>5. Attach a grease gun (t37) or power greaser to the grease fitting (30) on the front side of the Hammer Mounted Auto Lube pump assembly (FZ).</p>	

LUBRICATION

HAMMER MOUNTED AUTO LUBE GREASE LINE PRE-FILLING

6. Pump grease through the pump to the grease line (29) until a steady stream of grease (28) is realized at the opposite (hammer) end.

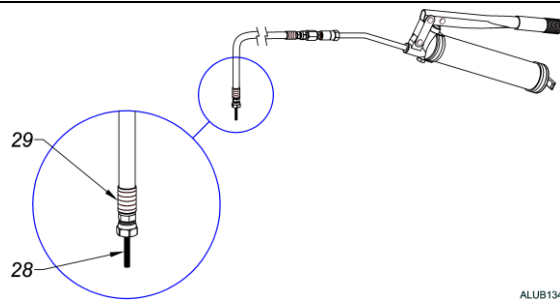

7. Re-attach the grease line (29) to the hammer assembly (KK).

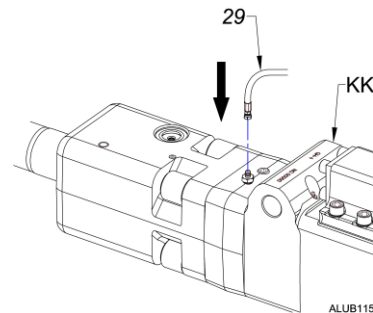

8. Pump twenty more shots of grease, using a grease gun (t37) or power greaser, into the pump assembly (FZ). This will prime the hammer tool cavity and pre-lube the tool (HH). Look for grease coming out around the tool at the tool bushing (see arrow in Fig. 2).

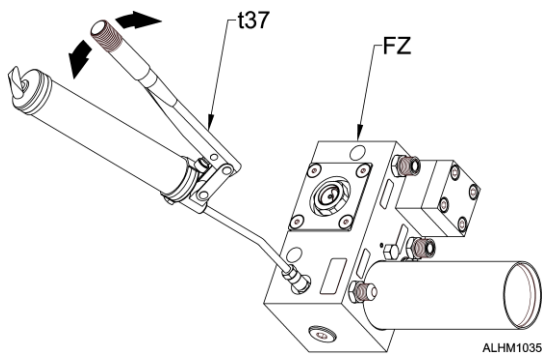

Fig. 1

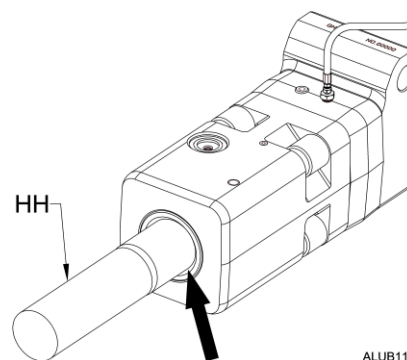

Fig. 2

NOTE: If the Auto Lube unit has run out of grease, the above procedure should be used to purge all air out of the grease line before using the hammer. Failure to do this will result in an intermittent supply of grease to the hammer.

LUBRICATION

LUBRICANT TERMS AND DEFINITIONS

TERM	DEFINITION
ADHESIVE	<i>The ability of grease, gear lubricant or oil to cling to metal.</i>
ANTI WEAR AGENTS	<i>Used to help combat metal-to-metal contact, thus reducing wear.</i>
COHESIVE	<i>The ability of grease, gear lube or oil to cling to itself, thus resisting tearing apart.</i>
CONSISTENCY	<i>Consistency of grease is its hardness or firmness. It is determined by the depth in millimeters to which the cone of a penetrometer sinks into a sample under specified conditions. Consistency of grease may be influenced by the type and amount of thickener, viscosity of oil, working and other factors.</i>
CONTAMINATION	<i>Foreign material that could damage a part.</i>
DROPPING POINT	<i>The minimum temperature at which the oil in a grease subjected to heat begins to actually drip and breakdown.</i>
EXTREME PRESSURE AGENTS	<i>Additives that under extreme pressure form an adherent film on metal surfaces, thus forming a film of protection.</i>
FILM STRENGTH	<i>Film strength is defined as the tendency of oil molecules to cling together. It is the ability of those molecules to resist separation under pressure between two metals and to hold these metal surfaces apart.</i>
FRICTION	<i>The resistance to fluid flow in a hydraulic system. (An energy loss in terms of power output.)</i>
GALLING	<i>Surface damage on mating, moving metal parts due to friction. A severe form of adhesive wear.</i>
LUBRICATION	<i>Use of a substance (grease, oil, etc.) to reduce friction between parts or objects that move against each other.</i>
NLGI	<i>A rating given to a grease from the National Lubricating Grease Institute. This rating determines the hardness of the grease and goes on from a 000 to a 6 rating. Most greases are NLGI #2 rated.</i>
OILINESS	<i>Oiliness is measured of the coefficient of friction of a lubricant. Oiliness or lubricity depends on the adhering characteristics of an oil. It is determined by the attraction between the molecules of the oil and the molecules of another material. Of two oils having the same viscosity but different degrees of fluid friction, the one with the lower friction index has the higher degree of oiliness.</i>
PUMP	<i>A device which converts mechanical force into hydraulic fluid power. Basic design types are gear, vane, and piston units.</i>

LUBRICATION

LUBRICANT TERMS AND DEFINITIONS

<i>TERM</i>	<i>DEFINITION</i>
<i>RESERVOIR</i>	<i>A container for keeping a supply of working fluid in a hydraulic system.</i>
<i>VIBRATION</i>	<i>A quivering or trembling motion.</i>
<i>VISCOSITY</i>	<i>Is the actual SAE weight of the product. Example motor oils come in 10, 20, 30, 40, 50 and 15/40 SAE weight. The viscosity designation of a lubricant indicates its internal resistance to flow.</i>

AUTO LUBE / UNDERWATER PORT IDENTIFICATION

NPK GH2, GH2S, GH2TS, GH4 and GH6 models are equipped with two ports on the main body (A) or impact ring/cylinder spacer (J) used in adapting for AUTO LUBE and underwater use. The air port (17) will allow the connection of an air line that will allow the hammer to be used underwater. The grease port (26), will allow for AUTO LUBE connection.

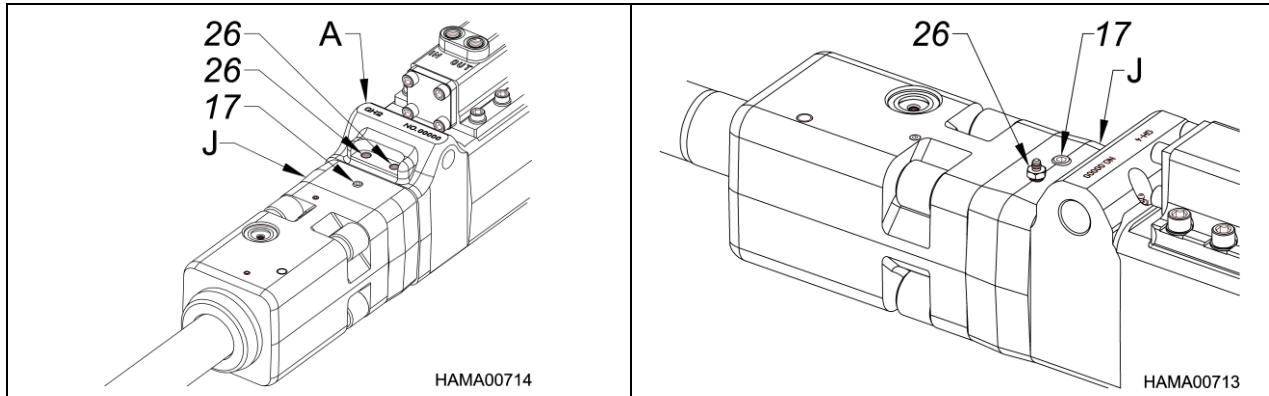

GH2, GH2S, GH2TS

GH4 – GH6

NPK GH06, GH07, GH1, GH2 and GH3 models are equipped with an impact ring/cylinder spacer (J) that must be machined with a port (17) for underwater use. The air port will allow the connection of an air line that will allow the hammer to be used underwater.

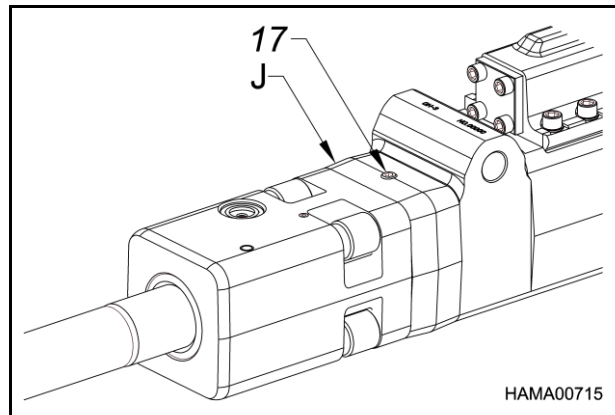

GH06, GH07, GH1, GH2, GH3

HIGH HEAT APPLICATION

NPK offers a high heat conversion kit for the GH3 through GH6 hammers.

HAMMER MODEL	KIT PART NUMBER
GH3	GH3-9505
GH4	GH4-9501
GH6	GH6-9500

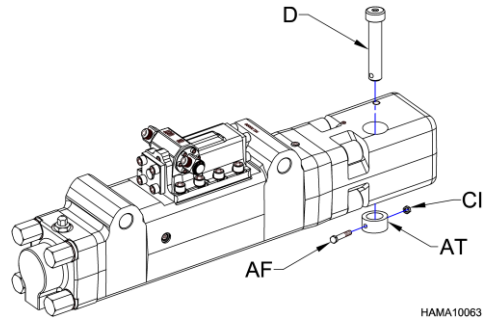

Kit includes:

AF	Hex Head Cap Screw
AT	Boom Pin Collar
C1	Hex Nut
D	Retaining Pin

NOTE: No special seals are required. Standard seals will work with “**MINERAL OIL**” based flame retardant oil.

ATTENTION

NOTE: Water glycol based fluid may shorten seal life.

ATTENTION

NOTE: Special protection for the hydraulic hoses is recommended.

START-UP OPERATION

ATTENTION

HAMMERS THAT ARE NEW, REBUILT, OR HAVE BEEN INACTIVE

Before using a new hammer for the first time, the first time after rebuild, or a hammer that has been inactive for a long period of time:

1. Check the nitrogen gas pressure.

The nitrogen gas pre-charge is factory checked before shipment. However, it is recommended the pressure be checked before using the NPK HYDRAULIC HAMMER for the first time. For the inspection procedure, see **CHECKING THE GAS PRESSURE**, page 64.

2. **At idle (THP1), raise the hammer off the ground.** Place hammer vertical and activate the hammer hydraulic circuit for 3 – 5 second intervals. Continue for an additional 3 – 4 times to ensure that all the air has been purged from the hoses and the hammer before first use. **Failure to do this could result in damage to the hammer's internal components.**

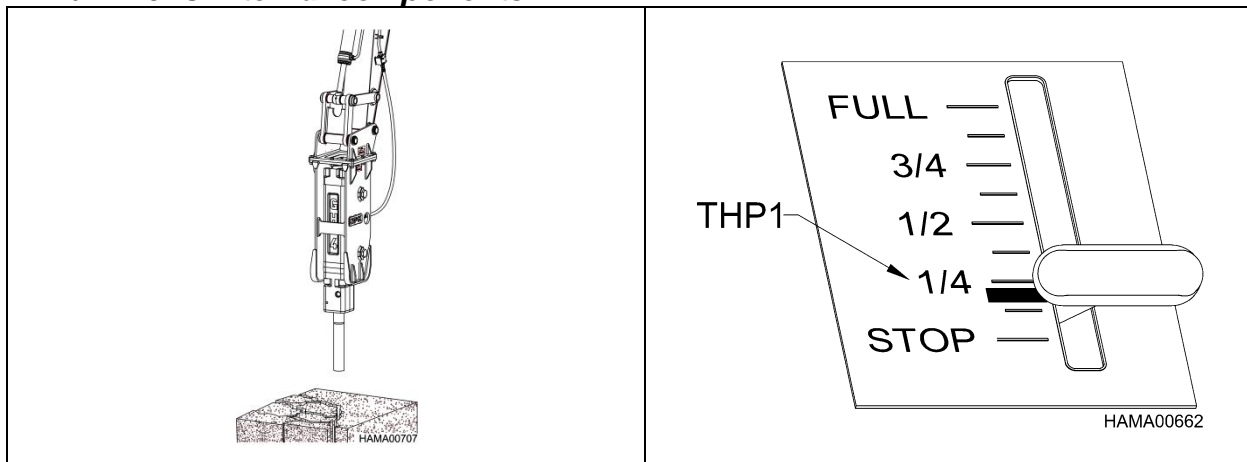

3. **Place hammer firmly against the material to be broken (see “PRELOAD THE TOOL BEFORE STARTING”).** Operate the hammer in a vertical position for approximately 10 minutes at one-half (THP2) engine speed. Increase engine speed to three-quarters (THP3) and continue operating at this speed for another 10 to 20 minutes. Increase to full engine speed (THP4). Maintain vertical position for the duration of the operation.

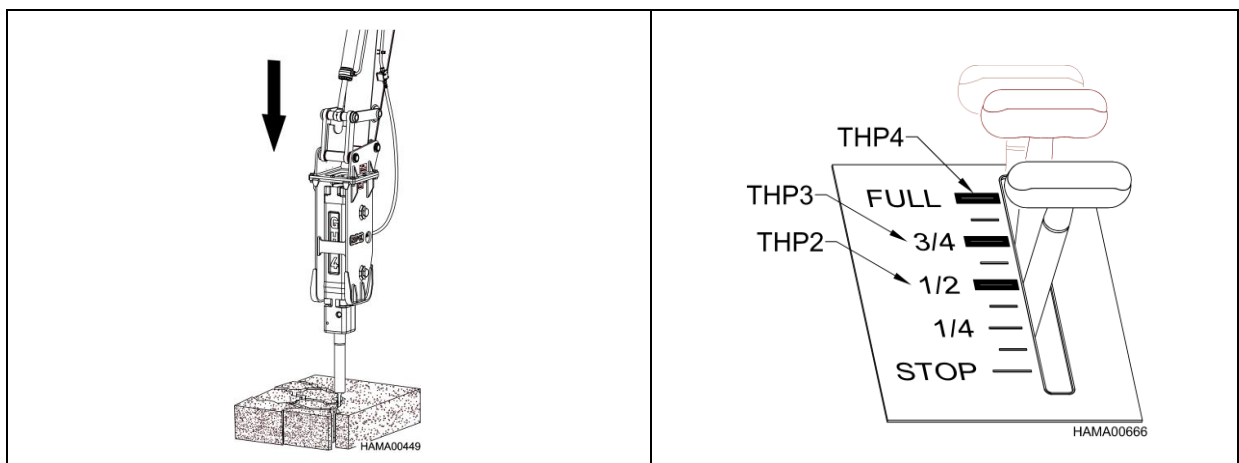

START-UP OPERATION

ATTENTION BEFORE STARTING THE HAMMER

PRE-OPERATION INSPECTION AND WARM UP

Before operating the NPK HYDRAULIC HAMMER, be sure to perform the specified ROUTINE INSPECTION, see page 50.

Warm up the NPK HYDRAULIC HAMMER, see below, and the base machine in accordance with the machine manufacturer's instruction manual. This is especially important during cold weather operation.

DAILY START-UP PROCEDURE

Operate the NPK HYDRAULIC HAMMER in the vertical position, at 3/4 engine throttle setting, for about 1-2 minutes. During this period, inspect the NPK HYDRAULIC HAMMER and INSTALLATION KIT for leaks or loose connections.

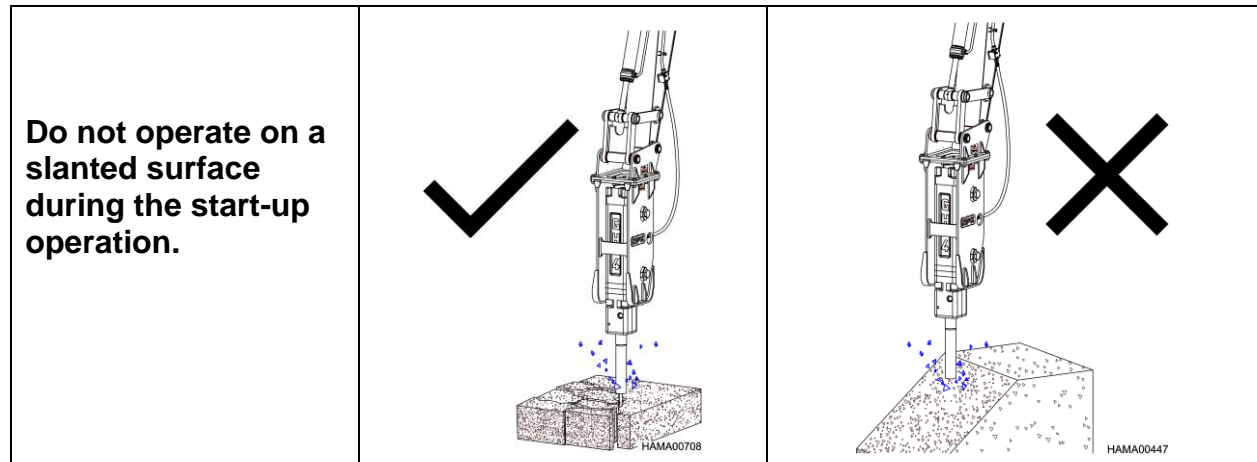

OPERATION

WARNING

SAFE OPERATING INSTRUCTIONS

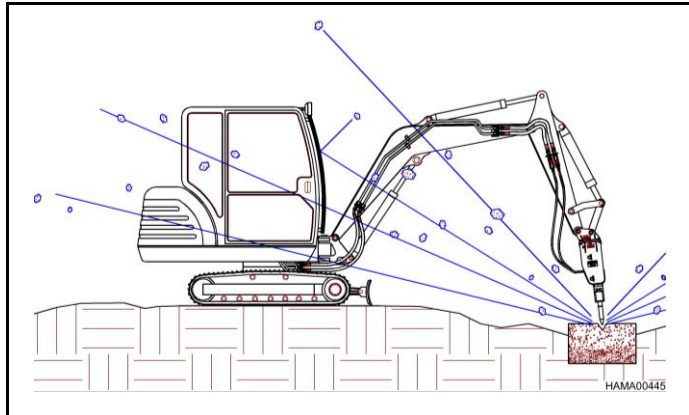

DO NOT OPERATE THE HAMMER WITHOUT AN IMPACT RESISTANT CAB WINDOW OR SHIELD IN PLACE

BEWARE OF FLYING DEBRIS FROM THE HAMMER TOOL POINT

An impact resistant cab window or shield must be in place to protect the operator.
Do not use the hammer in a way as to cause rock, etc. to be thrown towards the cab.

CAUTION

DO NOT USE THE HAMMER AS A HOIST

The hammer is not intended to lift an object. To do so, can be dangerous.

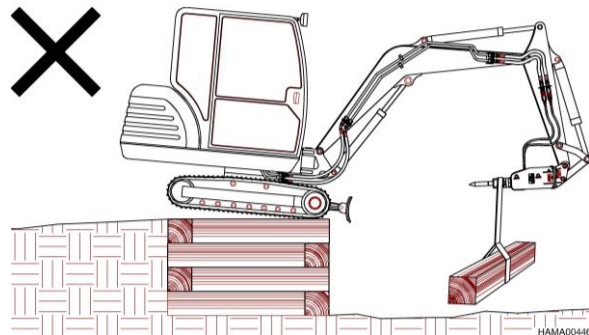

DO NOT TOUCH HOT TOOL AFTER USING!

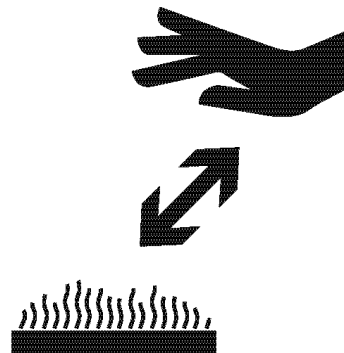

OPERATION

ATTENTION OPERATING TECHNIQUES & PRECAUTIONS

PRELOAD THE TOOL BEFORE STARTING

Press the tip of the demolition tool vertically against the object to be broken. Be sure the object is stable before activating the NPK HYDRAULIC HAMMER.

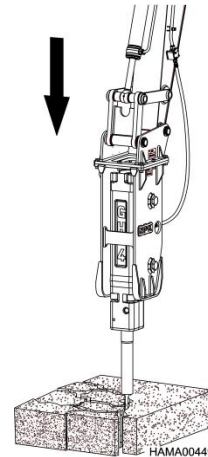

APPLY DOWNFORCE ON THE TOOL

Raise the front of the machine slightly by applying down force on the demolition tool. Press the control lever or the foot pedal to start the NPK HYDRAULIC HAMMER.

Applying excessive force to the hammer will raise the carrier too high and jolt the operator when the material breaks. Let the NPK HYDRAULIC HAMMER do the work.

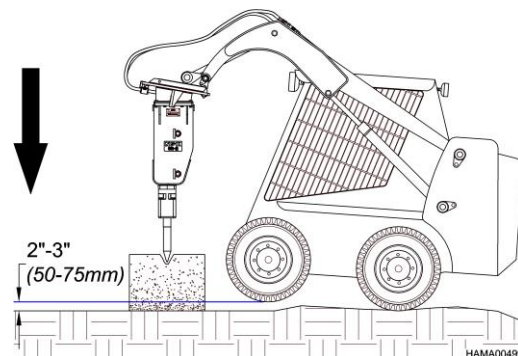

AVOID BLANK HAMMERING

As soon as the material is broken, release the control lever or pedal to prevent unnecessary blank hammering.

Blank hammering is continued hammer operation after the material is broken. This will overheat the hydraulic system, cause undue wear, and result in eventual tool retaining pin failures, see page 42.

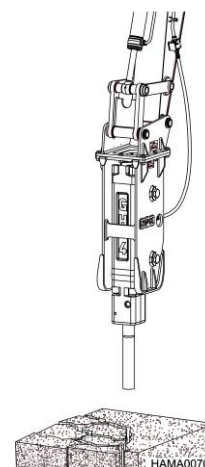

OPERATION

ATTENTION OPERATING TECHNIQUES & PRECAUTIONS

DO NOT SLANT HAMMER

For the most efficient demolition, align the direction of force (51) from the boom with the penetration direction (52) of the tool (HH). Failure to do this decreases the transfer of energy from the piston to the rock and increases the bending forces at the fulcrum of the tool. This unnecessary added stress leads to the following problems:

1. Premature bushing wear and/or tool breakage
2. Breakage of tie rods
3. Breakage of bracket bolts

When the tool binds from an incorrect working angle, the sound of the hammer changes.

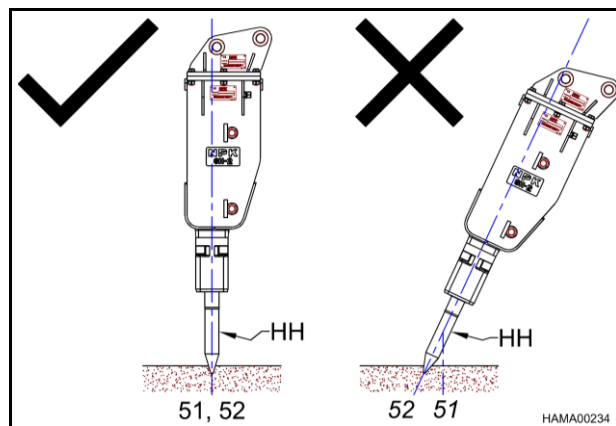

Keep the boom direction of force (51) in the same direction the tool is penetrating. Use the boom cylinder to preload the hammer (apply down force), and use the bucket and stick cylinders for alignment. Keep the tool tangent to the arc of the boom (54).

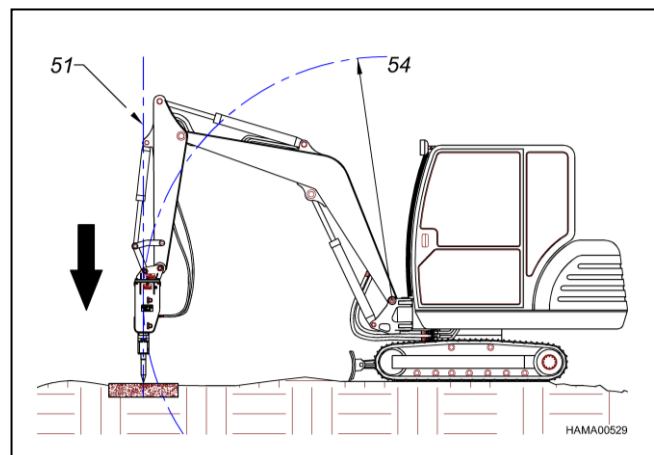

OPERATION

ATTENTION OPERATING TECHNIQUES & PRECAUTIONS

DO NOT USE THE HAMMER TOOL AS A PRY BAR

Excessive prying can cause premature bushing wear and tool or tie rod breakage. When hammering materials that allow the tool to penetrate before breaking, move the hammer slightly fore and aft to create a cone-shaped hole. The vented hole allows trapped dust and heat to escape, increases the tool penetration rate into the material, and prevents overheating the tool tip.

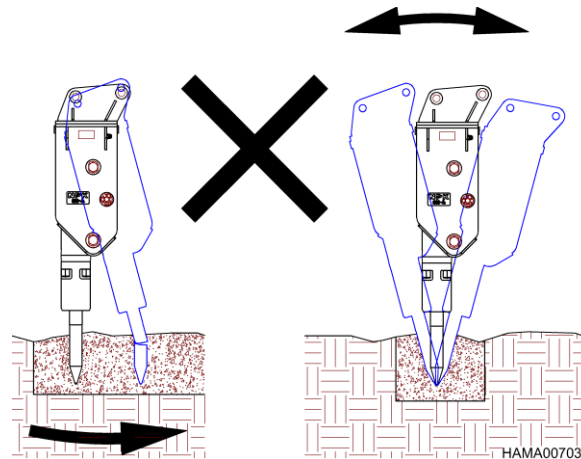

DO NOT HAMMER CONTINUOUSLY IN THE SAME POSITION FOR MORE THAN 30 SECONDS

If the tool cannot break or penetrate into the material after hammering in the same position for 30 seconds, change the working location. Hammering in the same position for a long time will reduce the working efficiency, increase the hydraulic oil temperature, overheat the tool tip and accelerate tool wear.

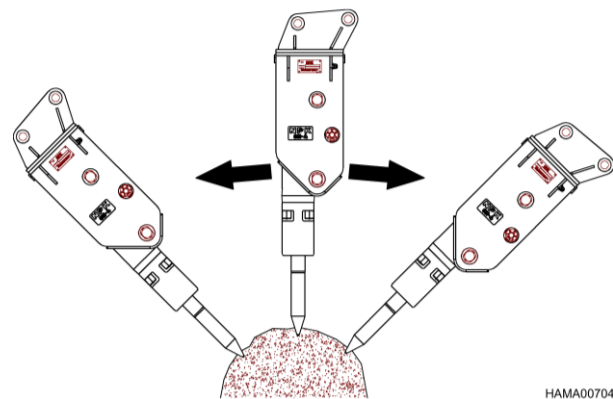

ALWAYS WORK BY BREAKING TO A FREE FACE

The material must have somewhere to break. Start at an edge.

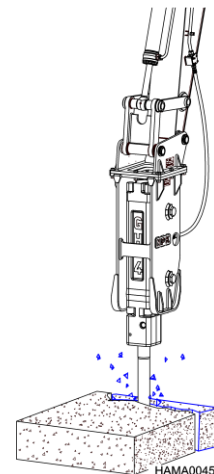

OPERATION

ATTENTION OPERATING TECHNIQUES & PRECAUTIONS

DO NOT DROP THE HAMMER RAPIDLY ON AN OBJECT

Remember, the hammer assembly (DR) is heavier than an empty bucket and will move faster than expected.

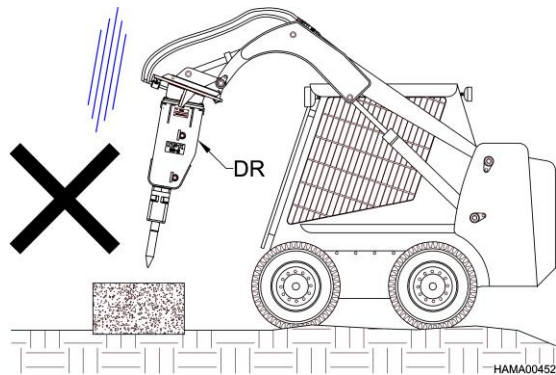

DO NOT USE THE HAMMER OR BRACKET TO MOVE LARGE OBJECTS

Do not use the hammer bracket for purposes other than for what it was intended.

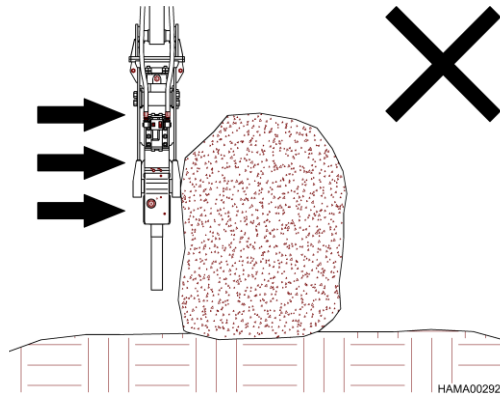

AVOID OPERATING THE HAMMER WITH CYLINDERS AT THE END OF STROKE

Continuous operation with the cylinders fully retracted (97) or extended (96) may damage the hydraulic cylinders.

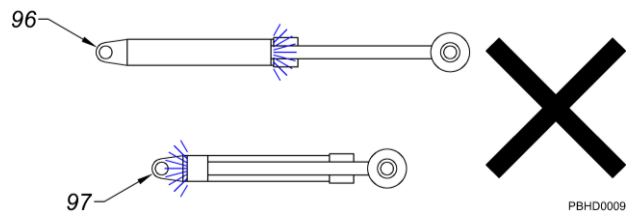

OPERATION

ATTENTION OPERATING TECHNIQUES & PRECAUTIONS

DO NOT OPERATE HAMMER UNDERWATER

Do not allow parts, other than the tool, to go below water level (115). Underwater operation will damage the hammer and allow water to enter the hydraulic system. The hammer can be modified for underwater operation - contact the NPK Dealer for more information.

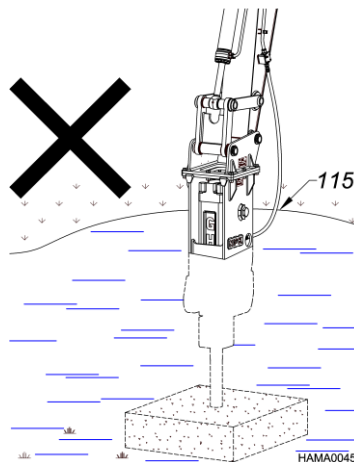

DO NOT SUBMERGE A HOT TOOL IN WATER!

The tip of the tool (HH) may be hot from operation. Submerging below water level (115) can cause the tip of the tool (HH) to become brittle and break prematurely.

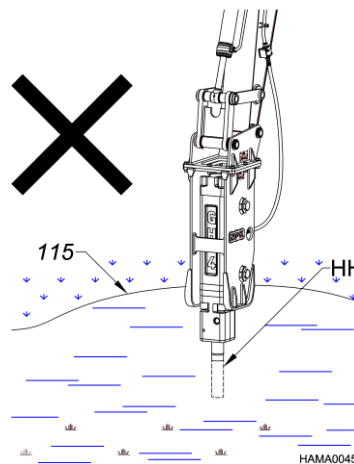

DO NOT ALLOW THE HAMMER TOOL TO HIT THE BOOM

Use caution when tucking the hammer in tight to the boom for transportation.

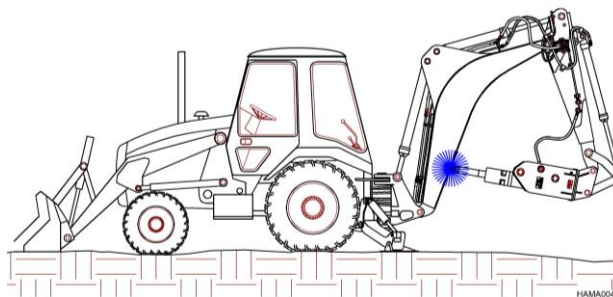

OPERATION

ATTENTION OPERATING TECHNIQUES & PRECAUTIONS

TAMPER PAD OPERATION

Always use the full width of the pad when compacting. Using part of the pad to compact can cause adapter tool breakage.

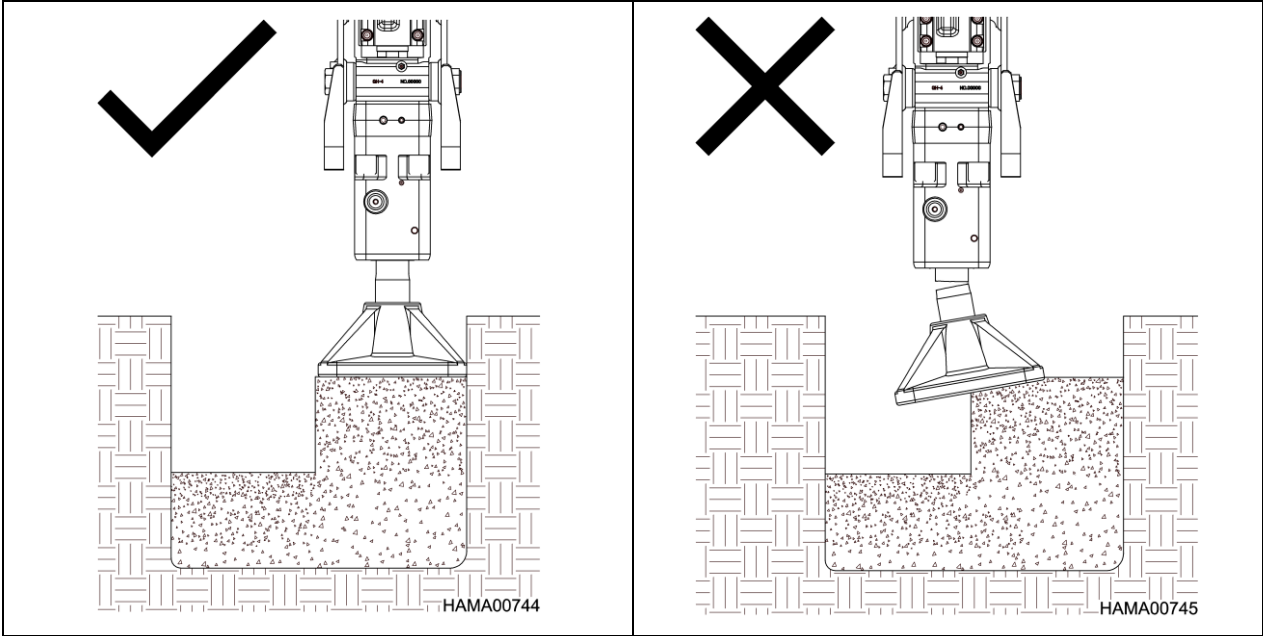

IMPACT ENERGY TRANSMISSION THROUGH TOOLS

A hydraulic hammer converts hydraulic power to kinetic energy. The kinetic energy is delivered by the hammer piston to the tool as an impact force.

Unlike a slowly transmitted force, such as the force with which a hydraulic cylinder extends, the impact force produced by the piston when it hits the tool, is transmitted through the interior of the tool as a compression stress wave until it reaches the rock, concrete, or other material that the tool is about to break. The compression wave speed is equal to the speed of sound through steel, i.e., approximately 15,000 ft/sec. Therefore, if the tool is three feet long, the impact force reaches the object to be broken 1/5000 (0.0002) second after the piston hits the tool.

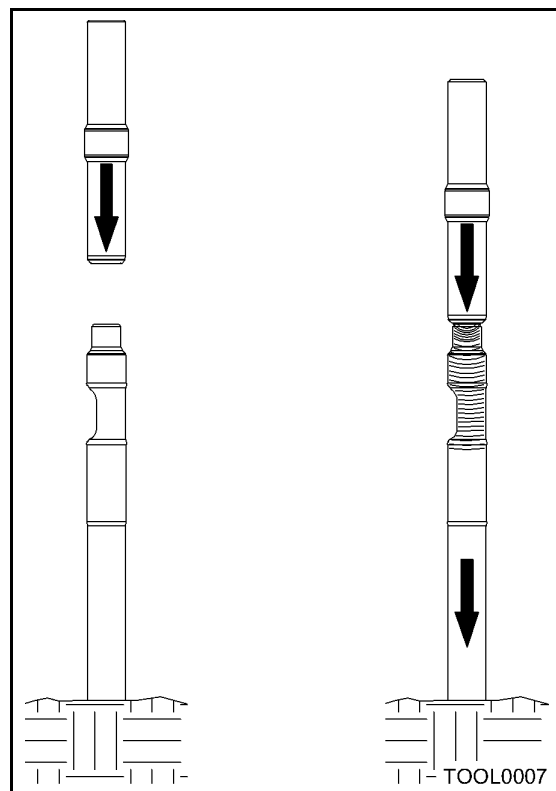

Impact force is transmitted as stress waves through the tool.

IMPACT ENERGY TRANSMISSION THROUGH TOOLS

IMPACT STRESS WAVES AT THE END OF THE TOOL

When the tool is in contact with the material to be broken, most of the compression stress waves are transferred to the material, and the energy of the compression waves then breaks the material. However, not all the energy of the compression waves is transmitted to the material to be broken, part of it is reconverted into reverse compression, or tensile, waves that then travel back through the tool.

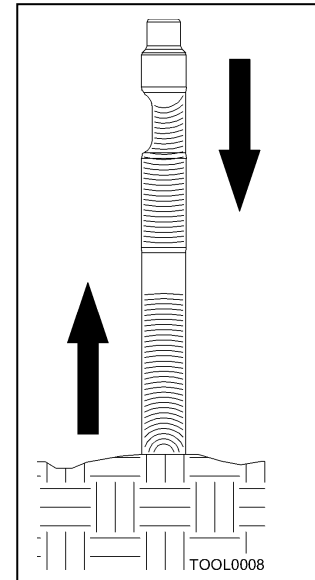

When the tool is not in contact with the material to be broken, the energy of the compression waves has nowhere to go and therefore, returns totally in the chisel as tensile waves. This is referred to as a “blank hammer blow”.

The compression waves and the tensile waves travel in a complex manner in the tool during hammer operation. While these waves are gradually being attenuated by the internal friction of the tool and by the friction between the tool and the tool holder bushings, the next impact strikes the tool. Excessively heavy contact between the tool and tool bushings causes uneven stress concentrations. This leads to premature tool failure, as seen in later sections of this manual.

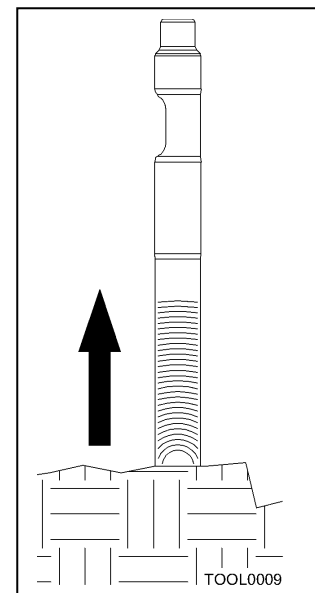

TOOL BREAKAGE

Description of tool failures, causes, preventative measures, and application of warranty.

TOOL BREAKAGE DUE TO EXCESSIVE BENDING MOMENT

If the tool is subjected to excessive bending moment caused by slant hammering or prying, the tool will break. Tool breaks will generally resemble one of the following examples:

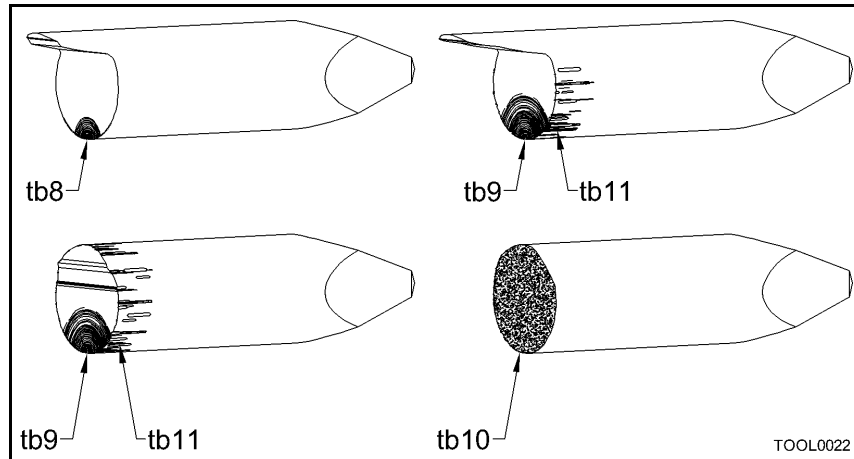

tb8. Starting point of crack that leads to breakage.	tb9. Starting point of break.
tb10. Sudden break from instant overload condition, (face will look very dull gray).	tb11. Galling

CHARACTERISTICS OF THE BROKEN SECTION

1. The starting point of a fatigue fracture is on the surface of the tool and located at the front or rear side of the tool, with the hammer installed on the excavator and viewed from the cab.
2. The tool has galled areas on its surface. The galling initiates a surface crack from which the fatigue fracture starts. The stress cracks, combined with bending loads and impact shock, can break the tool.

PREVENTATIVE MEASURES

1. Properly position the hammer so as not to develop a bending moment in the tool.
2. Apply sufficient grease to prevent the tool from developing cracks due to galling. This will also assure longer tool bushing life.

WARRANTY

NPK Warranty does not apply to this type of failure.

TOOL BREAKAGE

TOOL BREAKAGE DUE TO EXCESSIVE WEAR OF THE TOOL HOLDER BUSHINGS

If the hydraulic hammer is used with tool holder bushings worn beyond specifications, the tool will be at an excessive angle to the piston at the moment of impact. The entire force of the piston is concentrated in a small area of the impact head of the tool (Fig. 1). This results in the impact head being chipped or broken (Fig. 2 & 3). With the tool at an angle, and in excessive side loading contact with the tool holder bushings, the shock load traveling down the tool is unevenly concentrated (Fig. 1). This can result in the tool breaking through the retaining pin slot (Fig. 4).

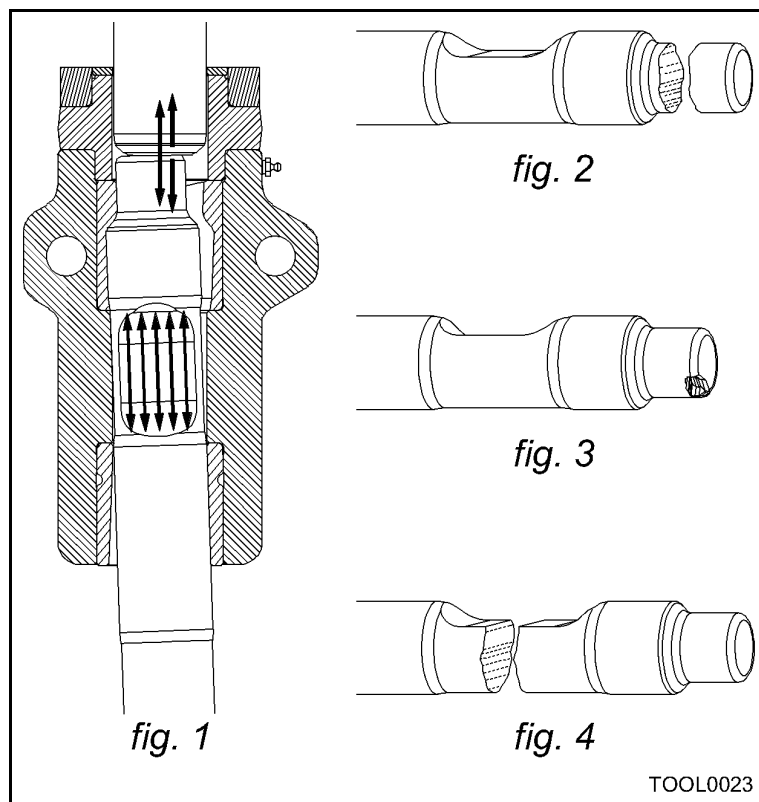

TOOL BREAKAGE

TOOL BREAKAGE DUE TO EXCESSIVE WEAR OF THE TOOL HOLDER BUSHINGS

PREVENTATIVE MEASURES

Replace the tool bushing (G), and/or tool (HH), when the tool to bushing gap (d15) reaches the maximum clearance. To determine whether the bushing or tool requires replacement, follow the instructions in the “**MAXIMUM TOOL TO TOOL BUSHING CLEARANCE**” section of this manual.

HAMMER MODEL	MAXIMUM CLEARANCE	
	in	(mm)
GH06	1/4	6
GH07	1/4	6
GH1	1/4	6
GH2/GH2S/ GH2TS	1/4	6
GH3	1/4	6
GH4	1/4	6
GH6	3/8	10

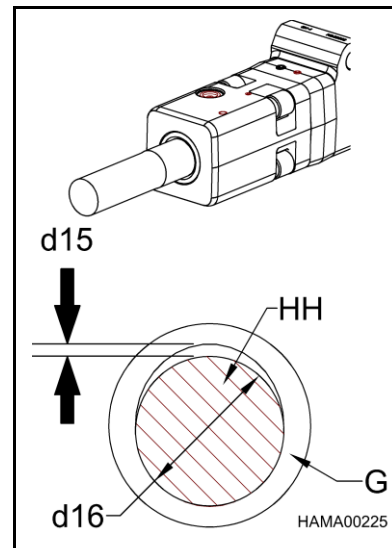

G. Tool Bushing
HH. Tool
d15. Clearance
d16. Tool Diameter

WARRANTY

NPK Warranty does not cover tool failure caused by worn tool holder bushings.

TOOL BREAKAGE

CHIPPING IN RETAINING PIN SLOT

The tool may become chipped at the upper end of the retaining pin slot where it contacts the retaining pin. Free standing oversize rock may sometimes be broken with only a few hammer blows. If the operator does not stop hammering immediately, the tool will hit the retaining pin (blank hammering), and can chip the upper end of the retaining pin slot.

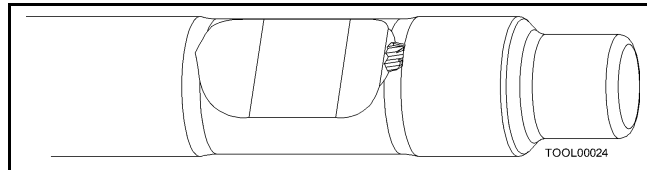

PREVENTATIVE MEASURES

When the material is broken, stop operating the hammer immediately. Periodically check the tool and grind smooth any chipped areas to prevent stress cracks.

DEFORMATION OF THE RETAINING PIN SLOT SIDES

The tool may become chipped or deformed in the area where it is in contact with the retaining pin. As the tool breaks material, it will try to follow any fracture lines in the material (Fig. 1). This causes a chisel point tool to twist in the tool holder. The retaining pin limits how far the tool can twist. If this happens often enough, the pin contact area of the tool can become chipped (Fig. 2) or deformed (Fig. 3).



PREVENTATIVE MEASURES

The operator should place the chisel point in line with fractures or laminations in the material, not at an angle. The tool should be checked periodically for chipped areas. Grind smooth any chipped areas to prevent stress cracks in the tool.

WARRANTY

NPK Warranty does not apply to these types of failures.

TOOL BREAKAGE

DEFORMATION OF THE TOOL TIP



Hammering continuously in one position for over 30 seconds will overheat the tool tip. If this is done repeatedly, the tip will lose temper and mushroom. Overheating wears the tip faster and can allow the tip to chip.

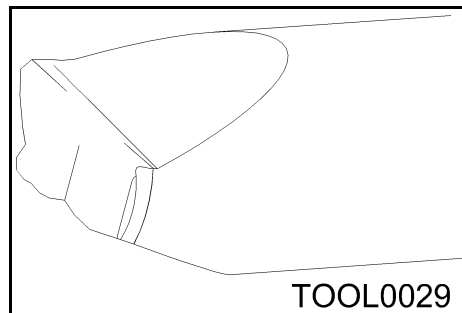
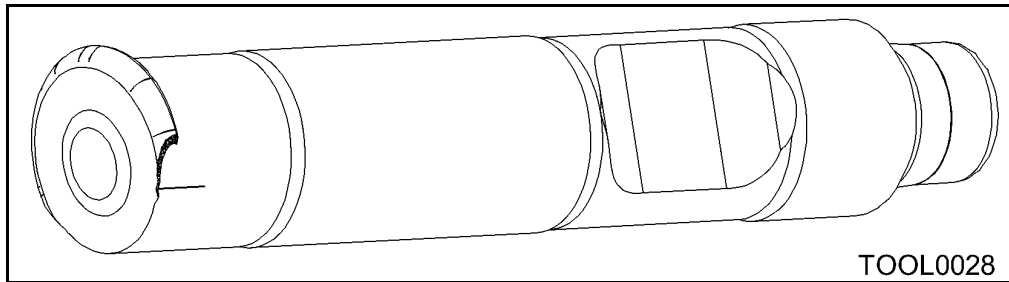

PREVENTATIVE MEASURES

Move tool position if material is not broken after 30 seconds of hammering. If the material still resists breaking, a larger hammer may be required.

WARRANTY

NPK Warranty does not apply to this type of failure.

TOOL BREAKAGE

CHIPPING OF A MOIL POINT TOOL TIP



Moil ("P") tools are intended for use on concrete or soft rock. The use of moil tools on hard rock may result in the point being chipped.

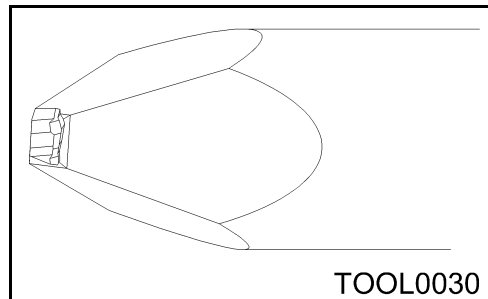

PREVENTATIVE MEASURES

Use a chisel point ("FX" or "FY") tool or a larger size hammer.

CHIPPING OF A CHISEL TOOL TIP

Chisel tool tips may be chipped due to hammer being undersize for application. Overheating tool by hammering for more than 30 seconds in one spot can cause chipping.

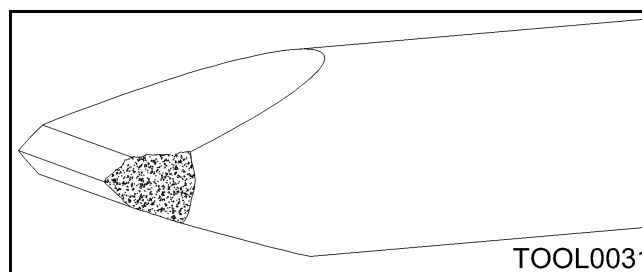

PREVENTATIVE MEASURES

Use correct size hammer for job conditions. Do not hammer for more than 30 seconds without moving hammer.

WARRANTY

NPK Warranty does not apply to these types of failures.

TOOL BREAKAGE

TEMPERATURE RELATED TOOL PROBLEMS

LOW TEMPERATURE

Metallic material becomes brittle in a low temperature environment and particularly sensitive to impact stress.

PREVENTATIVE MEASURES

Warm the tool before starting to operate the hammer when temperature is below 32° F, (0° C).

WARRANTY

NPK Warranty does not cover this type of failure.

EXCESSIVE SLANT HAMMERING

When constant slant hammering is performed while using boom downforce, the tool may become deformed as shown in the picture below.

HIGH TEMPERATURE

When the tool is used in a high temperature environment, such as for slag removal from a furnace, the tool may be deformed as shown in the picture below.

PREVENTATIVE MEASURES

Use compressed air to keep the tool cool enough not to deform.

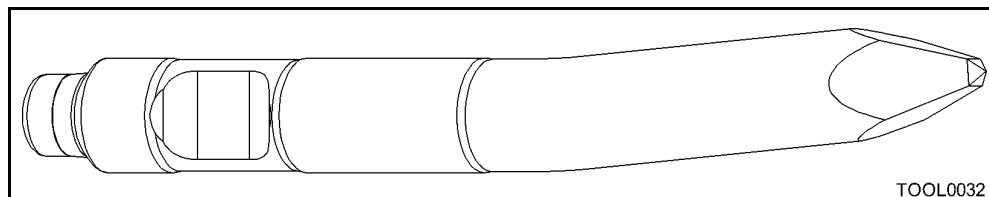

WARRANTY

NPK Warranty does not cover this type of failure.

TOOL BREAKAGE

TOOL BREAKAGE DUE TO CORROSION

Corrosion on the tool surface causes stress concentrations in the corroded area and a fatigue fracture can occur. These fractures, combined with impact stress, can lead to tool breakage.

PREVENTATIVE MEASURES

After using the tool in salt water, after exposing it to a corrosive environment, or before long term storage, be sure to rinse with fresh water. Dry the tool and coat it with grease to protect it from corrosion.

WARRANTY

NPK Warranty does not cover this type of failure.

TOOL BREAKAGE DUE TO DEFECTIVE MATERIAL

If metal fatigue originates from the interior, not the exterior, the material has some defect and fatigue will break the tool. The picture below illustrates the broken section. The starting point of breakage (tb9) is inside the tool, not on the surface.

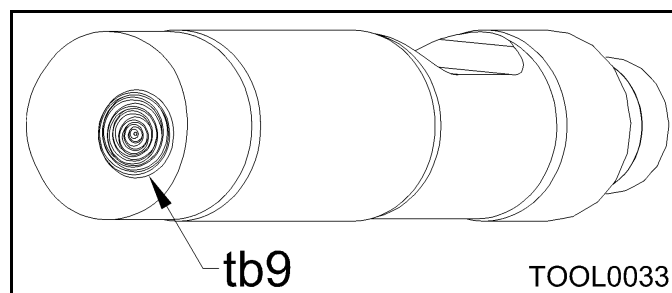

WARRANTY

NPK Warranty does cover this type of failure.

ROUTINE INSPECTION AND MAINTENANCE

1. VISUAL INSPECTION

Detect a potential problem early.

FASTENERS

Inspect all fasteners. Retighten as necessary. (See “**TORQUE VALUES FOR HAMMER FASTENERS**” in this manual.)

WELDS

Check for cracks, repair as necessary, (see the Service Manual for proper weld procedure.)

HOSES AND TUBING

Check for oil leaks, loose clamps and hose abrasion.

HYDRAULIC OIL

MAINTAIN A CLEAN HYDRAULIC SYSTEM

If non-petroleum oil is used, contact NPK Service Department for compatibility.

Keep hoses clean and capped when dismantling or storing hammer.

Change oil and filters as recommended by carrier manufacturer. Periodic oil sampling is recommended.

2. DEMOLITION TOOL LUBRICATION

Important: It is imperative that grease is maintained in the tool bushing contact area at all times. This may require hourly greasing depending on job conditions.

Important: The hammer must be in a vertical position with down force applied to push the tool all the way in. This prevents grease from entering piston impact area. **Pump grease into hammer until grease is seen coming out between the tool and tool bushing, see page 19.**

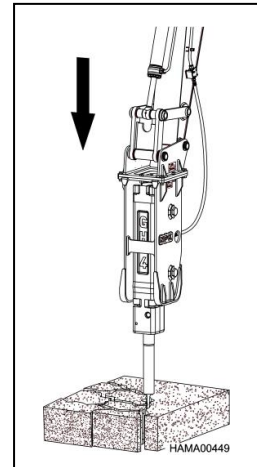

USE A GOOD QUALITY, HIGH TEMPERATURE EP#2 GREASE CONTAINING ANTIWEAR ADDITIVES. NPK recommends a lithium soap base EP (Extreme Pressure) NLGI #2 Grease, with Moly (Molybdenum Disulfide) or other surface protecting additives. A high drop point 350°F (177°C) grease is desirable.

If machine is equipped with an AUTO LUBE System, check grease reservoir daily.

3. TOOL and TOOL BUSHING WEAR

Check the tool and tool bushings for damage, wear, or deformation on a regular weekly basis. Replace the tool and/or bushings when wear exceeds the maximum clearance limit. See **MAXIMUM TOOL TO TOOL BUSHING CLEARANCE**, pages 55 and 56.

Do not hardface or sharpen the tool point with a cutting torch. Excessive heat from torching or welding causes embrittlement, breakage, and flying pieces. Resharpen only with a lathe or milling machine using sufficient cooling. Please consult your authorized NPK Dealer or NPK Service Department for additional information.



4. DO NOT SUBMERGE HAMMER UNDERWATER

Unless modified for underwater operation. Consult NPK Service at 440-232-7900 or see “**UNDERWATER MANUAL**” for instructions.

WEEKLY INSPECTION

1. FASTENERS

Inspect all fasteners and retighten as necessary, see **“TORQUE VALUES FOR HAMMER FASTENERS”**.

2. WELDS

Check for cracks and repair as necessary, see **“MOUNTING PLATE”**. *Consult your authorized NPK Dealer or NPK Service Department for additional information.*

3. TOOL RETAINING PIN

Remove the retaining pin and inspect for peening caused by excessive blank hammering. If necessary, grind edges smooth as shown in **“TOOL RETAINING PIN INSPECTION”**. The retaining pin must rotate freely.

4. DEMOLITION TOOL



Remove the demolition tool and inspect for peening caused by excessive blank hammering. If necessary, grind edges smooth as shown in **“TOOL INSPECTION”**.

5. GAS CHARGE

Check and adjust, if required, see **“NITROGEN GAS PRESSURE”** and **“CHECKING THE GAS PRESSURE”**.

TYPES AND APPLICATIONS OF TOOL



STANDARD TOOLS

DEMOLITION TOOL	SHAPE	APPLICATIONS
CHISEL (FX) The crosscut (FX) tool cuts at right angle, or crosswise, to the stick and boom of the excavator.		<ul style="list-style-type: none"> • Trenching • Cutting casting gates • Breaking oversize • General demolition
MOIL (P)		<ul style="list-style-type: none"> • Concrete breaking • Highway construction • General demolition
BLUNT (E)		<ul style="list-style-type: none"> • Secondary breaking • Breaking oversize • Slag removal

OPTIONAL TOOL

CORE (PC) for GH6		<ul style="list-style-type: none"> • Concrete breaking • Highway construction • General demolition
-----------------------------	---	---

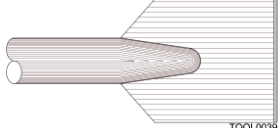
ACCESSORY TOOLS

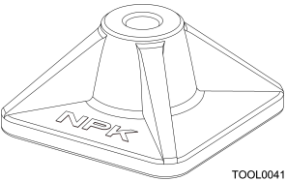
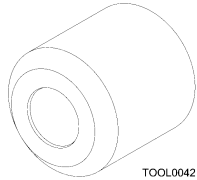
SPECIALTY TOOL	SHAPE	APPLICATIONS
FROST CUTTER Cross cut (SX), In Line (SY) for GH07 thru GH4		<ul style="list-style-type: none"> • Edge of trenching • Frost cutting
ADAPTER TOOL for GH07 thru GH4		<ul style="list-style-type: none"> • For attachments listed below
TAMPER PLATE (use with adapter tool) 9-1/2" x 9-1/2" for GH07 12" x 12" for GH1 thru GH2/GHS2 16" x 16" for GH3 thru GH4		<ul style="list-style-type: none"> • Soil compaction • Driving sheeting
POST and PIPE DRIVER (use with adapter tool) for GH1 thru GH4		<ul style="list-style-type: none"> • Driving guard rails • Driving fence posts

ATTENTION

TOOLS FROM H & E SERIES HAMMERS WILL NOT ALWAYS FIT GH SERIES! CHECK PART NUMBERS!

TOOL IDENTIFICATION

NPK demolition tools can be identified by the numbers found stamped in the retaining pin slot area. These numbers must be included in all warranty correspondences regarding a broken tool. Photos must also be included.

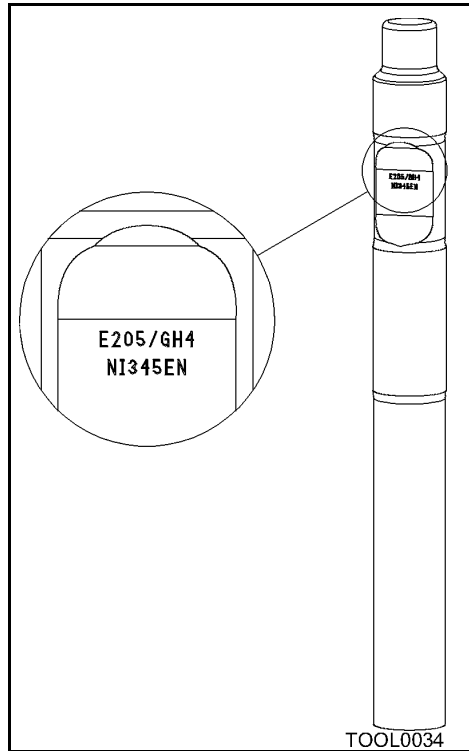

TOOLS

CHANGING THE TOOL

REMOVAL

1. Remove the retaining pin ring (E) by using pliers or a screwdriver (t22), see Figures 1 and 2. It will easily come out if pulled at an angle as shown in Figure 2.

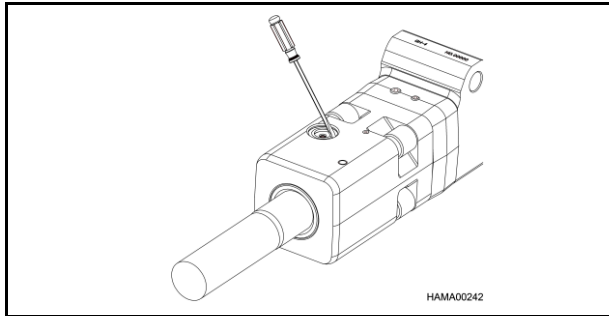

Figure 1

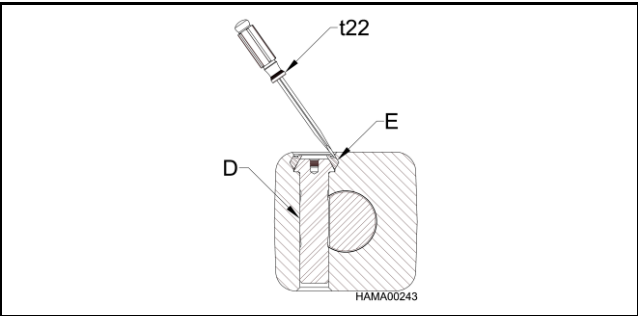

Figure 2

2. Screw an M12 bolt or cap screw (AF) into the retainer pin (D), see Figure 3.
3. Pull out retainer pin (D). If the retainer pin (D) is jammed, use a hammer and drift from the opposite side.
4. See **“RETAINING PIN INSPECTION”** for additional retaining pin inspection and reconditioning.

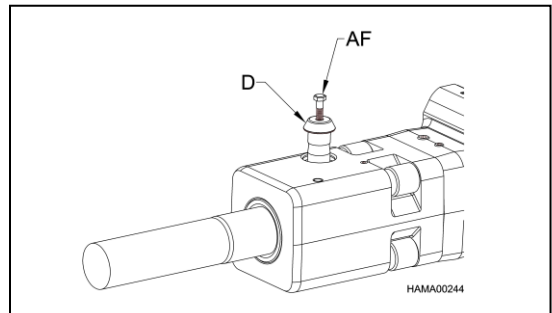

Figure 3

RE-INSTALLATION

1. Clean the retainer pin housing hole and retaining ring groove.
2. Coat the surface of the tool with grease, then install.
3. Apply grease to the retaining ring housing groove.
4. Coat the retaining pin with grease, then install.
5. Install the retaining ring in the following manner:
 - a. While deforming the retaining ring as shown in Figure 4, partially force it into the groove.
 - b. Using the handle of the screwdriver, press the rest of the ring into the groove, see Figure 5.

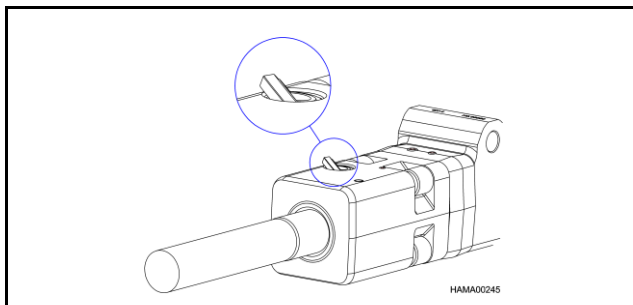

Figure 4

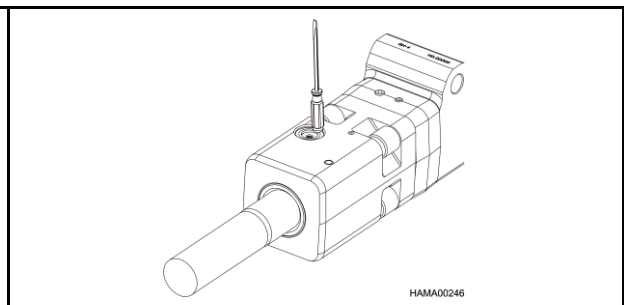

Figure 5

TOOLS

MAXIMUM TOOL TO TOOL BUSHING CLEARANCE

Replace the tool bushing (G), and/or tool (HH), when the tool to bushing gap reaches the maximum clearance. To determine whether the bushing or tool requires replacement, follow the instructions and charts shown below:

Step 1

Measure the tool to bushing gap (d15) with the hammer horizontal, as illustrated below. If the clearance is at or greater than the charted maximum clearance, then move on to the next steps.

HAMMER MODEL	MAXIMUM CLEARANCE	
	in	(mm)
GH06	1/4	(6)
GH07	1/4	(6)
GH1	1/4	(6)
GH2/GH2S/ GH2TS	1/4	(6)
GH3	1/4	(6)
GH4	1/4	(6)
GH6	3/8	(10)

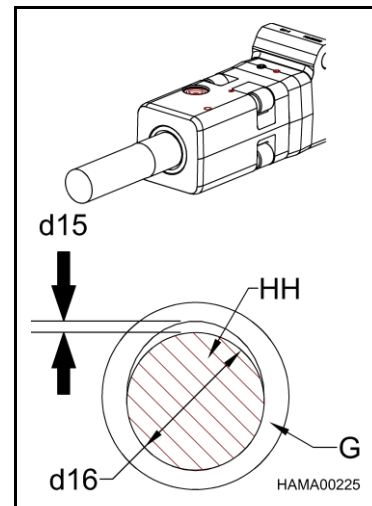

Step 2

Remove the tool from the tool holder. Measure the diameter (d16) of the bearing surface of the tool (HH), which is located on each side of the retaining pin groove. The minimum tool diameter is compared to a new tool bushing only. If the tool is at or below the charted value, the tool must be replaced.

HAMMER MODEL	NEW TOOL DIAMETER		MINIMUM TOOL DIAMETER	
	in	(mm)	in	(mm)
GH06	1.6	(41)	1.4	(35)
GH07	1.9	(47)	1.6	(41)
GH1	2.2	(57)	2	(51)
GH2/GH2S/ GH2TS	2.6	(66)	2.4	(60)
GH3	3	(76)	2.8	(71)
GH4	3.4	(86)	3.2	(81)
GH6	4.2	(106)	3.8	(96)

TOOLS

MAXIMUM TOOL TO TOOL BUSHING CLEARANCE

Step 3

Measure the inside diameter of the tool bushing. The maximum tool bushing inside diameter is compared to a new tool only. If the tool bushing dimensions are at or above the charted value, the bushing must be replaced.

HAMMER MODEL	NEW BUSHING INSIDE DIAMETER		MAXIMUM BUSHING INSIDE DIAMETER	
	in	(mm)	in	(mm)
GH06	1.67	(42.4)	1.87	(47.4)
GH07	1.87	(47.4)	2.07	(52.6)
GH1	2.26	(57.4)	2.46	(62.6)
GH2/GH2S/ GH2TS	2.61	(66.4)	2.82	(71.6)
GH3	3.01	(76.4)	3.21	(81.6)
GH4	3.40	(86.4)	3.61	(91.6)
GH6	4.19	(106.4)	4.55	(115.6)

Step 4

Compare the tool and bushing to the charts in Step 2 and Step 3. Choose the new component (tool or bushing) that will bring the maximum clearance to below the value seen in the chart of Step 1. Replacing both the tool and bushing would bring the clearance back to new.

NOTE: NPK offers a tool for measuring tool to tool bushing clearance.

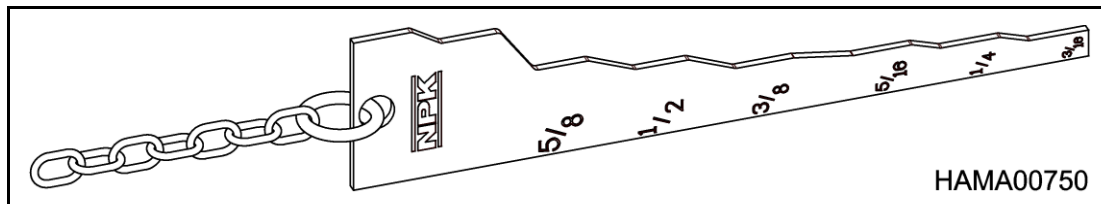

TOOLS

TOOL INSPECTION

1. Deformation may occur on the tool in the retaining pin contact area (15) or thrust surface (31). If these areas are mushroomed, the tool may become difficult to remove from the tool holder. Dress with a grinder.

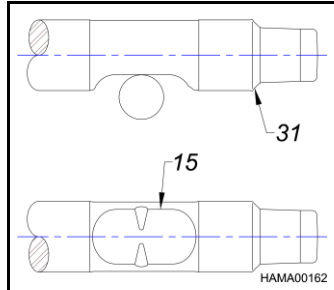

2. Excessive blank hammering will cause chipping (16) in the retaining pin contact area (15). If neglected, the chipping may reduce the life or cause failure of the tool retaining pin. Dress with a grinder.

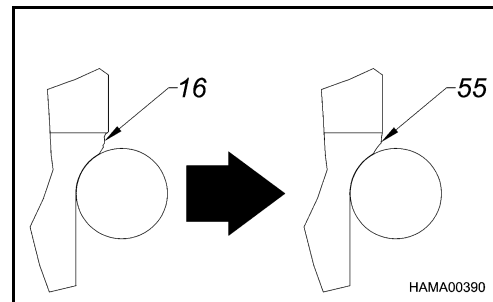
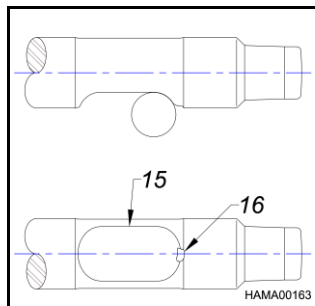

3. Excessive blank hammering can cause retaining pin breakage/failure. Replace retaining pin.

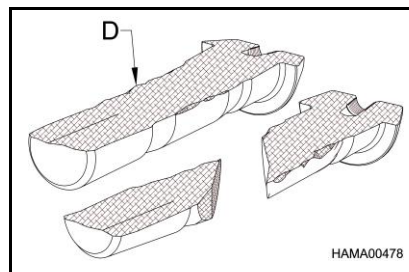

4. If chipping (16) is found at the top of the tool, replace the tool. If neglected, the piston impact surface will be damaged (13 is normal, 14 needs to be replaced).

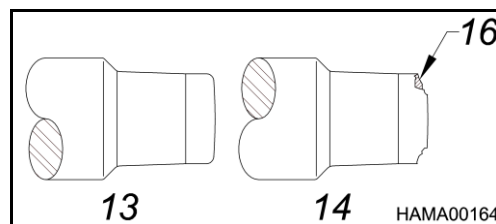

TOOLS

CHISEL TOOL SHARPENING



Worn chisel tools can be sharpened by machining according to the dimensions below. **DO NOT** hardface or sharpen the tool point with a cutting torch! Re-sharpen only with a lathe or milling machine using sufficient coolant.

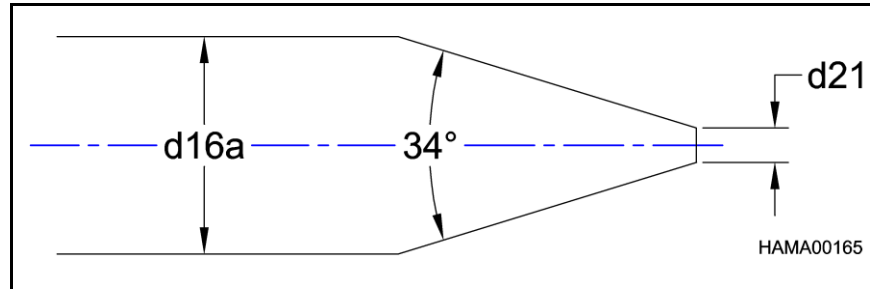

HAMMER MODEL	d21		d16a (ref.)	
	in	(mm)	in	(mm)
GH06	.25	(6.4)	1.57	(40)
GH07	.25	(6.4)	1.77	(45)
GH1	.38	(9.7)	2.17	(55)
GH2/GH2S/ GH2TS	.38	(9.7)	2.52	(64)
GH3	.38	(9.7)	2.91	(74)
GH4	.50	(12.7)	3.31	(84)
GH6	.50	(12.7)	4.09	(104)

TOOLS

STANDARD LENGTH FOR NPK TOOLS

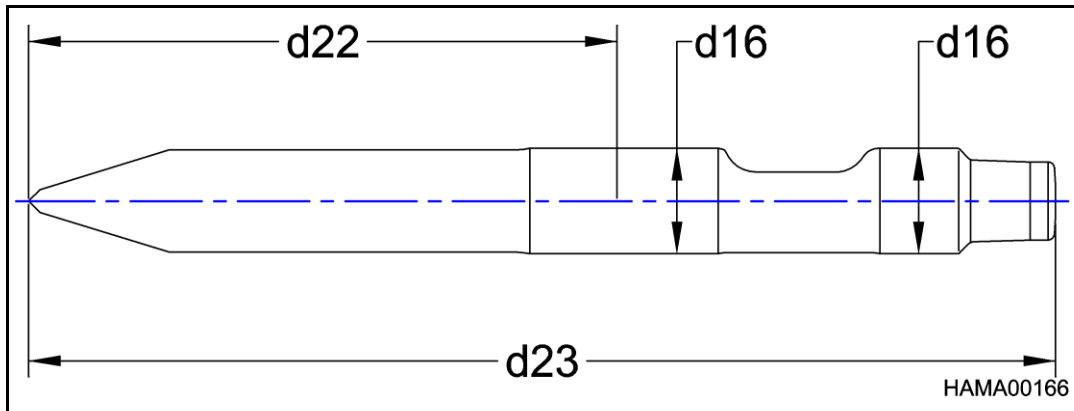

d23 = Length of tool from top to bottom.

d22 = Length of tool exposed from bottom of tool bushing to end of tool.

d16 = Diameter of bearing surface of tool.

HAMMER MODEL	NEW TOOL DIAMETER (d16)		NEW TOOL LENGTH (d23)		NEW WORKING LENGTH (d22)	
	in	(mm)	in	(mm)	in	(mm)
GH06	1.63	(41.4)	19.3	(490)	12.2	(311)
GH07	1.83	(46.6)	20.7	(527)	13.1	(333)
GH1	2.23	(56.6)	23.6	(599)	13.6	(346)
GH2/GH2S/ GH2TS	2.58	(65.6)	25.5	(648)	14.4	(367)
GH3	2.98	(75.6)	28.5	(725)	16.1	(408)
GH4	3.37	(85.6)	33.0	(838)	18.0	(458)
GH6	4.16	(105.6)	38.0	(966)	19.7	(500)

NOTE:

Minimum tool length is determined by the depth of material penetration that is required.

TOOLS

TOOL RETAINING PIN INSPECTION

The tool retaining pin (D) serves to keep the tool in place when the hammer is raised off the ground for repositioning. The retaining pin will become worn during normal use. **Figure "A"** shows the retaining pin when it is new. **Note:** *the two guide grooves (AN).* The guide groove areas and the area (122) between the grooves is where the wear will take place. If large, flat areas are found here, the pin must be replaced. *This would indicate that the hammer is not being greased frequently enough.* See **"LUBRICATION"**, **"GREASING PROCEDURE"**.

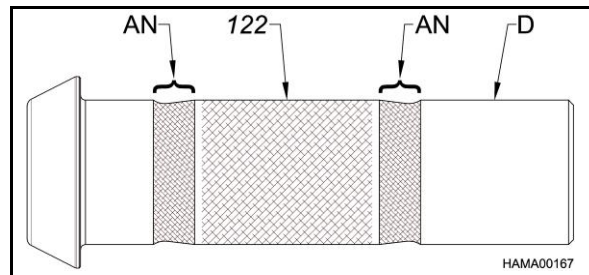

Figure "A"

Buildup (20) will occur on the pin as shown in **Figure "B"**.

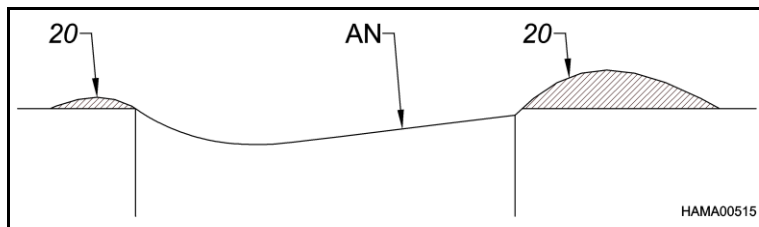

Figure "B"

Grind these areas (20) to remove any burrs as shown in **Figure "C"**. Reuse the pin.

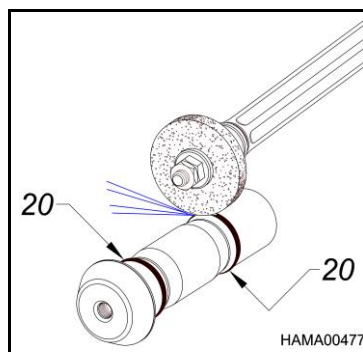

Figure "C"

TORQUE VALUES FOR HAMMER FASTENERS

If hammer or hammer bracket fasteners are found to be loose, use the following chart. If repairs are to be made, see the NPK Hydraulic Hammer Service Manual.

HAMMER MODEL	*HAMMER BRACKET			**ADAPTER BRACKET		
	BOLT	BOLT TORQUE		BOLT	BOLT TORQUE	
	DIA.	ft. lbs.	(Nm)	DIA.	ft. lbs.	(Nm)
GH06	1"-12	500	(678)	5/8"-11	165	(225)
GH07	1"-12	500	(678)	5/8"-11	165	(225)
GH1	1"-12	500	(678)	5/8"-11	165	(225)
GH2/GH2S/ GH2TS	1"-12	500	(678)	5/8"-11	165	(225)
GH3	1-1/4"-12	1000	(1356)	5/8"-11	165	(225)
GH4	1-1/2"-12	1250	(1695)	5/8"-11	165	(225)
GH6	1-1/2"-12	1250	(1695)	1"-12	750	(1020)

* Torque hammer bracket bolts using anti-seize compound.

** **DO NOT** torque adapter bracket bolts using anti-seize compound.

GAS CHARGE

NITROGEN GAS PRESSURE

The nitrogen gas pressure must be measured with no preload on the tool. Remove the tool; or position the hammer with the tool fully extended against the tool retaining pin. The hammer must not be resting vertical on the tool. The gas pressure in the hammer will vary according to the gas temperature.

PREFERRED METHOD

The preferred method to measure or charge the nitrogen gas pressure is with the hydraulic system temperature stabilized at maximum operating temperature. The chart showing values for “**Operating Temperature**” should be used, see below.

ALTERNATE METHOD

The nitrogen gas pressure can be measured or charged at ambient temperature (cold), before operating the hammer. See the chart “**Ambient Temperature**” below.

ATTENTION DO NOT OVERCHARGE THE HAMMER!

Exceeding the gas pre-charge specifications can result in damaging hammer components. The NPK WARRANTY does not cover failures resulting from exceeding the specified nitrogen gas pressure.

NITROGEN GAS PRE-CHARGE

HAMMER MODEL	AT AMBIENT TEMPERATURE (cold before operating)		AT OPERATING TEMPERATURE (hot, after 1 to 2 hrs. operation)	
	psi	(bar)	psi	(bar)
GH06	350	(24)	405	(28)
GH07	350	(24)	405	(28)
GH1	350	(24)	405	(28)
GH2/GH2S/ GH2TS	350	(24)	405	(28)
GH3	350	(24)	405	(28)
GH4	375	(26)	435	(30)
GH6	390	(27)	450	(31)

**Specifications subject to change without notice.*

Pressures listed are maximum allowed. Use tolerance of minus 25 psi (2 bar).

GAS CHARGE ADAPTER

MODELS GH06, GH07, GH1, GH2/GH2S/GH2TS

The NPK Models GH06, GH07, GH1 and GH2/GH2S/GH2TS hydraulic hammers have a gas charge fitting in the gas head that is different from all other NPK hydraulic hammers. After removing the existing plug (g12), the adapter (P/N GH000-1000) (g13) is threaded on to the existing gas charge fitting. This adapter is included in the gas charge kit that is provided with the hammer and allows use of the standard NPK gas charge valve (P/N 30604040) (g1), see next page.

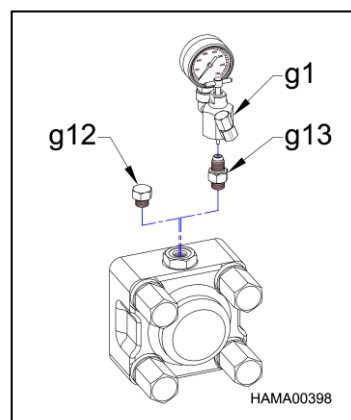

GAS CHARGE

GAS CHARGING KIT

ALL NPK HYDRAULIC HAMMERS are furnished with the following gas charging kit. In addition, a nitrogen tank and pressure regulator valve (not furnished with the hammer) is required. These can be obtained from your local welding supply house. An optional regulator valve, part no. 21101060, is available from NPK.

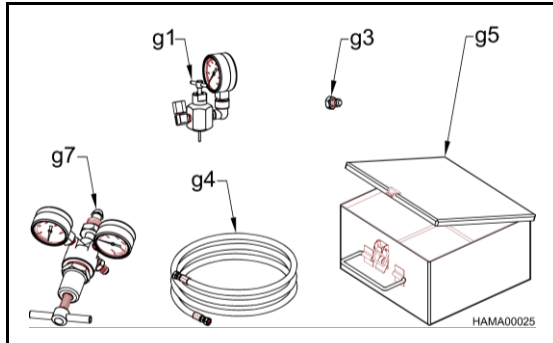

- g1. CHARGE ADAPTER (PART NO. 30604040)
- g3. PLUG (PART NO. 30102050)
- g4. HOSE (PART NO. 20118010)
- g5. CHARGING KIT BOX (PART NO. 35001030)
- g7. OPTIONAL REGULATOR VALVE (PART NO. 21101060)

CAUTION

Be advised that when using special charge adapter (g13) to adapt for the use of standard NPK gas charge valve (g1), it is important to make sure that pin (g14), bottom picture, is not bent or damaged in any way. If pin (g14) is bent or damaged, it may not be possible to check the charge in the hammer. When the standard NPK gas charge valve is coupled to the adapter (g13), pin (g15) should move downward approximately $.125"$ (3.175 mm) as the T-handle (g2) is turned clockwise.

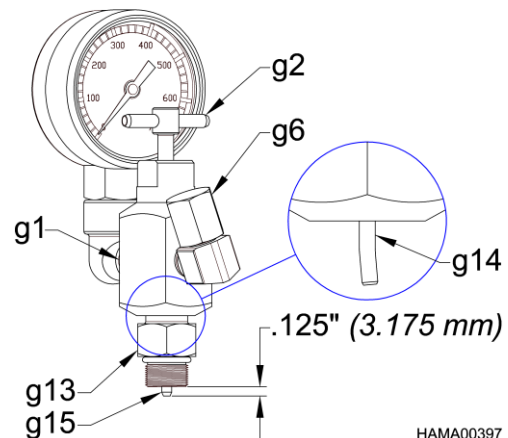

NOTE: *If the pin (g14) in the center of the NPK gas charge valve (g1) is bent, checking and charging the hammer may not be possible.*

GAS CHARGE

CHECKING THE GAS PRESSURE

Inspect the nitrogen gas pressure every 100 hours.

PROCEDURE

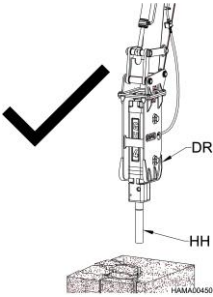
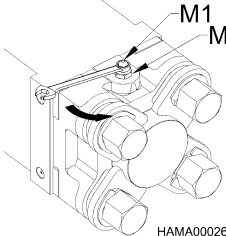
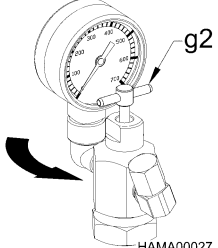
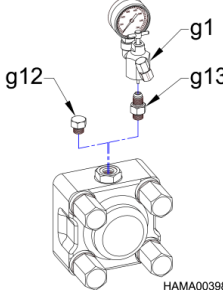
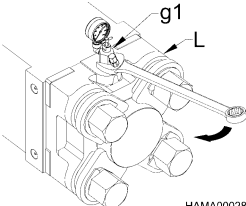
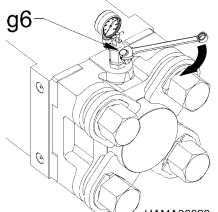
<p>1. The gas pre-charge is measured with no preload on the tool (HH). Remove the tool or position the hammer assembly (DR) with the tool fully extended.</p>	 <p>HAMA00450</p>
<p>2. Remove the charge valve cap (M1) from the hammer charge valve (M). Do not remove the charge valve assembly!</p>	 <p>HAMA00026</p>
<p>3. Turn the NPK charge adapter T-handle (g2) to a full counterclockwise position.</p>	 <p>HAMA00027</p>
<p>4. MODELS GH06, GH07, GH1, GH2/GH2S/GH2TS Remove plug (g12). Install adapter (g13) part no. GH000-1000 into the female port on the gas head. Install NPK charging adapter (g1).</p>	 <p>HAMA00398</p>
<p>4. MODELS GH3, GH4 and GH6 Only Install the NPK charging adapter (g1) on the hammer charge valve located on hammer gas head (L).</p>	 <p>HAMA00028</p>
<p>5. Tighten the charge adapter cap (g6).</p>	 <p>HAMA00029</p>

GAS CHARGE

CHECKING THE GAS PRESSURE

6. Turn the T-handle (g2) clockwise. As the T-handle is screwed in, a resistance is encountered. By turning the T-handle further, the nitrogen gas pressure will be indicated on the pressure gauge (g8). Stop turning the T-handle when the gauge reads pressure. ***Do not overtighten!***

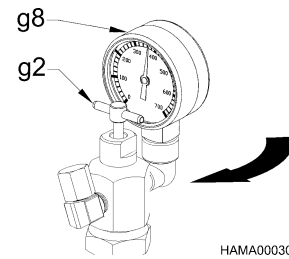

7. Compare the gauge pressure with the “**NITROGEN GAS PRE-CHARGE**” chart in the “**NITROGEN GAS PRESSURE**” section. If the gas is 25 psi (2 bar) or more below the specification, proceed to the “**NITROGEN GAS CHARGING PROCEDURE**” section of the manual. If the pressure is correct, go to the next step.
8. Turn the T-handle counterclockwise until it stops, as in step 3.
9. Slowly loosen the charge adapter cap to relieve the nitrogen gas pressure trapped in the charge valve.
10. Remove the charge adapter from the hammer charge valve.
11. Replace the charge valve cap on the charge valve.

GAS CHARGE

CHARGING THE HAMMER

CAUTION USE NITROGEN GAS ONLY.

STAY CLEAR OF THE TOOL WHILE CHARGING THE HAMMER WITH GAS. The tool may be impacted by the piston and forced out abruptly.

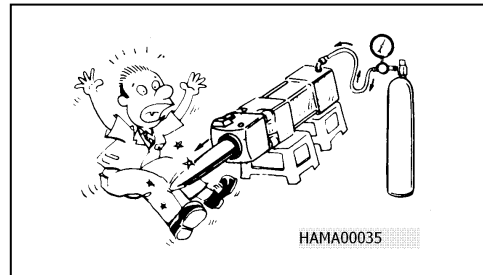

PROCEDURE

1. Carry out steps 1 thru 4 of “CHECKING THE GAS PRESSURE”.

<p>2. Install a pressure regulator (g7) on a tank (g9) of nitrogen gas.</p>	
<p>3. Connect a hose (g4) from the pressure regulator (g7) on the nitrogen tank (g9) to the charge adapter (g1).</p> <p>4. Turn the T-handle (g2) on the charge adapter clockwise.</p>	
<p>5. Turn the handle on the tank regulator (g7) counterclockwise to a fully closed position. Do not overtighten!</p> <p>6. Open the valve (g10) on the nitrogen tank (g9) by turning the handle counterclockwise.</p>	
<p>7. Slowly adjust the regulator on the nitrogen tank to the correct pressure by turning the handle clockwise. Refer to the “NITROGEN GAS PRE-CHARGE” chart in the “NITROGEN GAS PRESSURE SECTION”.</p>	
<p>8. Charge the nitrogen gas, per the gas charge decal (g11), until the pressure gauge (g8) on the charge adapter (g1) is at the correct setting, then turn the T-handle (g2) counterclockwise all the way out.</p> <p>9. Close the nitrogen tank valve then remove the hose (g4) from the charge adapter.</p>	

GAS CHARGE

DISCHARGING THE GAS PRESSURE

PROCEDURE

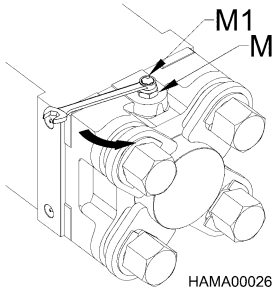
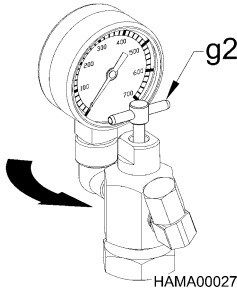
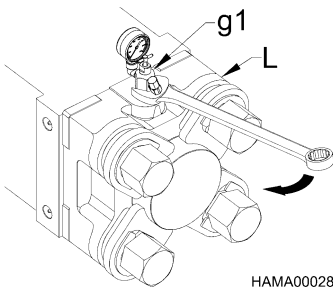
 <p>HAMA00026</p>	 <p>HAMA00027</p>	 <p>HAMA00028</p>
<p>1. Remove the charge valve cap (M1) from the charge valve (M). Do not remove the charge valve assembly!</p>	<p>2. Turn the NPK charge adapter T-handle (g2) to a full counterclockwise position.</p>	<p>3. Install the NPK charge adapter (g1) onto the hammer charge valve located on the hammer gas head (L).</p>

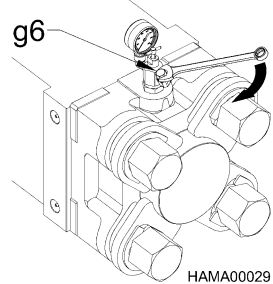
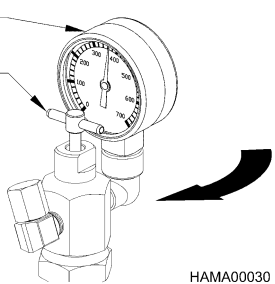
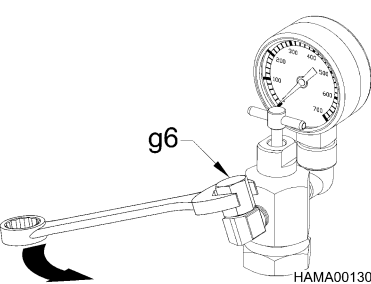
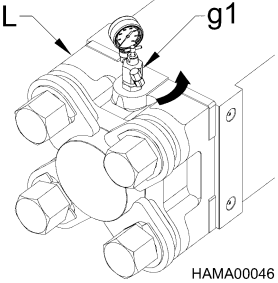

REMOVE THE VALVE CAP ONLY, NOT THE CHARGE VALVE ASSEMBLY!

 <p>HAMA00029</p>	 <p>HAMA00030</p>	 <p>HAMA00130</p>
<p>4. Tighten the charge adapter cap (g6).</p>	<p>5. Turn the T-handle (g2) clockwise. As the T-handle is screwed in, a resistance is encountered. By turning the T-handle, the nitrogen gas pressure will be indicated on the pressure gauge (g8). Stop turning the T-handle when the gauge reads pressure. Do not overtighten!</p>	<p>6. Loosen the charge adapter cap (g6) VERY SLOWLY! The gas pressure will gradually decrease to zero. When it gets to zero, remove the cap.</p>  <p>HAMA00046</p>
<p>7. Remove the charge adapter (g1) from the gas charge valve on the hammer gas head (L), then, reinstall the charge valve cap.</p>		

STORAGE OF HYDRAULIC HAMMER

For short term storage between jobs, place the hammer horizontal on wood blocks (t20) or on a pallet. Be sure that the tool end of the hammer is lower than the gas end. Also, be sure the tool (HH) is liberally greased and the hydraulic hoses (AO) are capped. Cover with a waterproof tarp (t21), not shown.

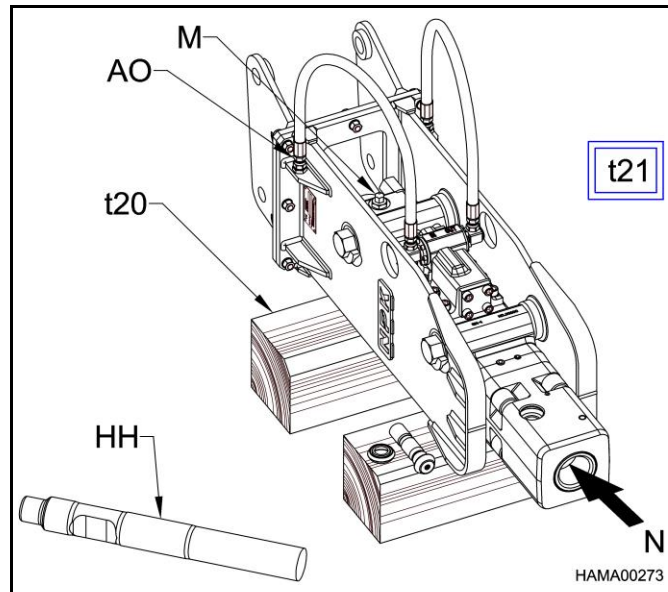

If the NPK HYDRAULIC HAMMER is not to be used for a long period of time (months), it is recommended the gas pressure be discharged at the charge valve (M). The tool (HH) should be removed, and the piston (N) pushed all the way in. Be sure the hydraulic hoses are plugged and grease the exposed end of the piston (N). Grease and reinstall the tool (HH). Cover with a waterproof tarp (t21), not shown.



DO NOT CLEAN the tool holder bore (111) of the hammer with a steam cleaner or high pressure washer (t58). This could cause rust to form then in turn, cause damage to the hammer piston!

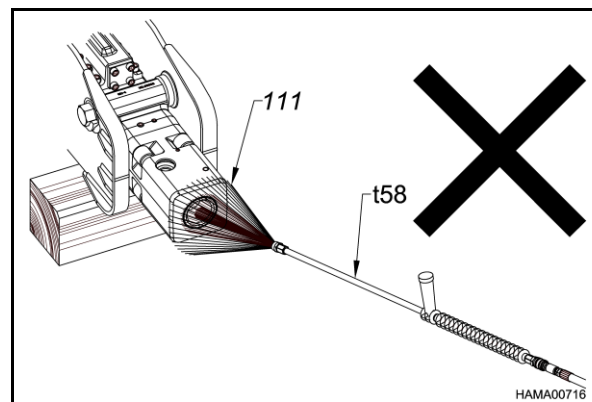

WARRANTY REGISTRATION FOR NEW UNITS

Complete and send to NPK after installation or complete online at www.npkce.com.
Online warranty registration can be done by the dealer or the end user.

The registration can be done in any of the following ways:

1. Mailed to:
NPKCE
7550 Independence Dr.
Walton Hills Ohio 44146
2. Faxed: 440-232-6294(U.S.) (+1)(440)232-6294(outside U.S.)
3. Completed online at :
www.npkce.com

The online registration can be done by the dealer or the end user.

Dealers:

- In the tool bar click on DEALERS.
- Using your username and password, log into the system.
- At the left of the next page click on REGISTRATION.
- Complete the fields with an orange diamond next to them.
- At the bottom of this area, click the START REGISTRATION box and continue.
- If the registration is completed online, there is no need to mail or fax the warranty registration.

End users / non NPK dealers

- In the tool bar click on DEALERS
- You do NOT need to fill in username and password.
- In the left column, click on the REGISTRATION.
- Complete the fields with an orange diamond next to them.
- At the bottom of this area, click the START REGISTRATION box and continue.
- If the registration is completed online, there is no need to mail or fax the warranty registration.

TOOL WARRANTY

STANDARD DEMOLITION and ACCESSORY TOOLS WARRANTY (30 days)

NPK Construction Equipment, Inc. ("NPK") warrants that new Standard Demolition Tools, and other Standard Accessory Tools sold by NPK will be free from defects in material or workmanship for a period of thirty (30) days, starting from the date of installation. NPK reserves the full right to determine if, and to what extent, warranty adjustments may be made for breakage of the demolition or other accessory tools. ***NPK Tool Warranty does not cover labor or travel expenses.***

THIS WARRANTY DOES NOT APPLY TO:

- Custom or special application tools which are excluded from warranty.

NPK RESPONSIBILITY

NPK will, at its option, replace with a new or reconditioned tool, any warranted tool that fails by reason of defective material or workmanship, free of charge delivered at a place of business of an NPK Dealer. Tool breakage is specifically covered ONLY for straight across breakage as shown at locations A. Note: The tool to bushing gap must be verified and reported to NPK. Failure to provide this information will make this failure non-warrantable, see pages 55 and 56.

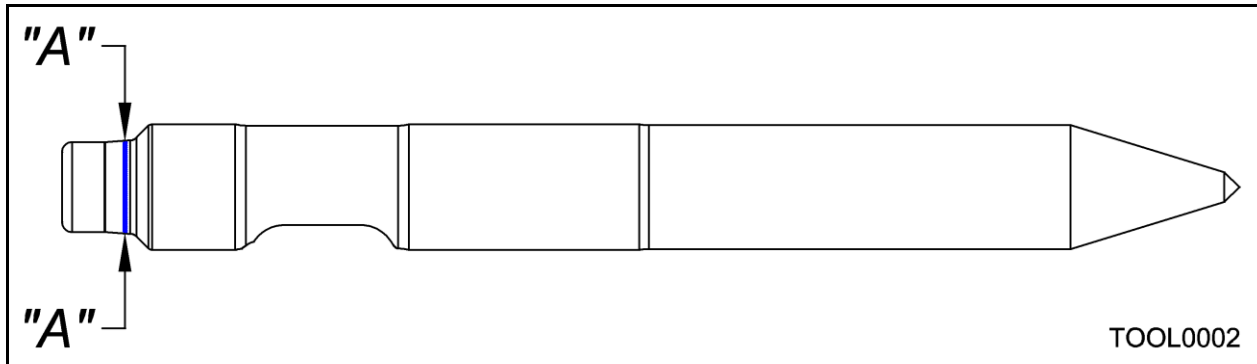

For warranted tool failures, a prorated credit, up to 80% maximum, will be issued for tools with tip wear greater than 50 mm on chisel andmoil points, or 30 mm on blunt end tools. Note: Parts replaced under warranty become the property of NPK.

TOOL WARRANTY

USER RESPONSIBILITY

- **Photos and all numbers from retaining pin slot must accompany all warranties submitted to NPK. These photos can be 35 mm, polaroid, or digital.**
- The installer, user, operator, repairer, assumes responsibility to read, understand and comply with NPK's written INSTALLATION, OPERATOR and SERVICE INSTRUCTIONS.
- All labor costs.
- Any expense incurred by field repair.
- Tool failures as shown at locations tb (see NPK Operators Manual for correct operating procedures):

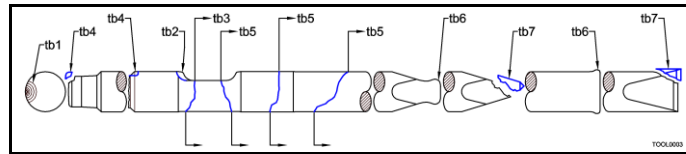

- | | | |
|--------------------------------|--|---|
| <p>CAUSE OF FAILURE</p> | <p>tb1 – Typical break from bending overload.</p> <p>tb2 and tb3 – repeated blank hammering.</p> <p>tb3 – bending overload due to excessive wear of the tool bushings.</p> <p>tb4 – corner loading due to excessive wear of the tool bushings.</p> | <p>tb5 – bending overload from excessive prying or slant hammering.</p> <p>tb6 – deformation from overheating by hammering in the same position for more than 30 seconds.</p> <p>tb7 – chipped, due to wrong application, or overheating by hammering in same position for over 30 seconds.</p> |
|--------------------------------|--|---|

THESE WARRANTIES DO NOT COVER FAILURES RESULTING FROM:

- Installation, alteration, operation, maintenance, repair or storage which NPK judges improper.
- Inadequate lubrication.
- Exceeding the tool and/or tool bushing wear limit.
- Unreasonable delay in making a repair after being notified of a potential product problem.

THESE WARRANTIES SPECIFICALLY EXCLUDE:

- Any tool which is altered, welded, hardfaced or sharpened.
- Replacement due to tip or shank wear.
- Installations not approved by NPK.
- Use of parts not sold by NPK. **THE USE OF “WILL FIT” PARTS WILL VOID THE WARRANTIES OF ANY AND ALL PARTS DAMAGED AS A RESULT OF THE FAILURE OF THE “WILL FIT” PARTS.**
- Parts shipping charges in excess of those which are usual and customary. (Air freight, unless pre-approved, will not be covered.)
- Duties, brokerage fees, and local taxes.

WARRANTY REPAIRS DO NOT EXTEND THE STANDARD WARRANTY PERIOD.

LIMITATIONS AND EXCLUSIONS

Violation of any federal, provincial, state, or local laws, ordinances, rules or regulations, or removal or alteration of product serial numbers void NPK's written product warranties. **Application for warranty must be made within 30 days of failure/repair.**

WARRANTY STATEMENTS



3 YEAR LIMITED WARRANTY GH-SERIES HYDRAULIC HAMMER

NPK genuine parts (including tool bits) must be used in the hammer for the complete term of the warranty. The use of non-NPK parts will void this warranty in its entirety. This warranty is Non-Transferable.

WARRANTY COVERAGE (Year 1):

NPK CONSTRUCTION EQUIPMENT, INC. ("NPK") warrants that new GH-Series Hydraulic Hammers sold by NPK will be free from defects in material and workmanship for a period of twelve (12) months, starting from the date of delivery to the first user. This warranty covers parts and labor subject to the terms hereof and will cover service items for a period of six months, (e.g., all seals, o-rings, rubber mounts, and tie rods.)

WARRANTY COVERAGE (Year 2):

For a period of twelve (12) months beginning after the expiration of the first year of coverage, the NPK warranty covers the main body, tool holder, gas head, valve case, piston, and sleeves. No other parts are warranted, and labor associated with warranty service is not covered.

WARRANTY COVERAGE (Year 3):

For a period of twelve (12) months beginning after the expiration of second year of coverage, the NPK warranty covers the main body, tool holder, gas head, and valve case. No other parts are warranted, and labor associated with warranty service is not covered.

THIS WARRANTY DOES NOT APPLY TO:

DEMOLITION TOOLS and ACCESSORY TOOLS, HYDRAULIC and MOUNTING INSTALLATION KIT PARTS, HOSES, or REPLACEMENT PARTS, which are covered by other warranties.

NPK RESPONSIBILITY

NPK will, at its option, either repair or replace, with a new or reconditioned part, any warranted part that fails by reason of defective material or workmanship. Such repair or replacement must be performed at the place of business of an authorized NPK Dealer. NPK's warranty covers costs of warranted parts and up to 75% of the authorized dealer's hourly shop rate for labor. Note: parts replaced under warranty become the property of NPK. **NOTE: NPK's warranty does not cover any labor for any repair past the initial 12-month coverage period.**

- Operation after discovery of defective or worn parts.
- Unreasonable delay in making a repair after being notified of a potential product problem.
- Two work-shift per day hammer operation.
- Steel mill operation.

USER RESPONSIBILITY

- Application for warranty service must be made within 30 days of discovery of a defect covered by this warranty.
- Photos must accompany all warranty claims. These photos can be prints or digital (preferred).
- The installer, user, and operator of the covered equipment is responsible for reading, understanding, and complying with NPK's written INSTALLATION, OPERATOR, and SERVICE INSTRUCTIONS.
- The purchaser is responsible for:
 - Registering the NPK product with NPK at the time of installation.
 - All costs associated with transporting the NPK product, or equipment to which the NPK product is installed, to an authorized NPK Dealer or other authorized location. NPK is not responsible for any expense incurred in field repair.
 - Supplying a hydraulic oil sample from the carrier machine upon request by NPK.
- THE USER IS RESPONSIBLE FOR USING THIS PRODUCT IN A SAFE AND LAWFUL MANNER IN COMPLIANCE WITH APPLICABLE OSHA REGULATIONS.

NPK's WARRANTY SPECIFICALLY EXCLUDES:

- Repairs performed by anyone other than an authorized NPK Dealer.
 - Use of parts not sold by NPK. **THE USE OF "WILL FIT" PARTS WILL VOID ALL NPK WARRANTIES.**
 - All wear items (e.g., retaining pin, tool bushings, and fasteners).
 - Labor hours deemed excessive by NPK.
 - Shipping charges in excess of those that are usual and customary. (Air freight, unless pre-approved, is not covered.)
 - Duties, brokerage fees, and local taxes.
 - Shop supplies and oil.
- *WARRANTY REPAIRS DO NOT EXTEND THE STANDARD WARRANTY PERIOD.**

THESE WARRANTIES DO NOT COVER DEFECTS OR FAILURES RESULTING FROM:

- Normal wear and tear.
- Misuse, abuse, alteration, or improper installation.
- Maintenance, repair, or storage which NPK judges improper.
- Failure to perform daily visual inspections as specified in the NPK manuals.
- Lack of lubrication, improper installation, poor maintenance, or improper operation.
- Exceeding the tool and/or tool bushing wear limit.
- Underwater operation without the NPK Underwater Kit installed on the hammer and supplying air to the hammer per the NPK Underwater Instruction Manual.

LIMITATIONS AND EXCLUSIONS

Violation of any federal, provincial, state, or local laws, ordinances, rules or regulations, or removal or alteration of product serial numbers, will void NPK's warranties.

This warranty sets forth NPK's only obligations with respect to any claims of failure, defects, or deficiencies in products sold by NPK. **NPK MAKES NO OTHER WARRANTIES OR REPRESENTATIONS WHATSOEVER, EXPRESS OR IMPLIED, OF THE QUALITY, PERFORMANCE, DURABILITY, MATERIALS, WORKMANSHIP, SUITABILITY, CONDITION, DESIGN, OR UTILITY OF PRODUCTS SOLD BY NPK, INCLUDING, WITHOUT LIMITATION, IMPLIED WARRANTIES OF MERCHANTABILITY AND FITNESS FOR A PARTICULAR PURPOSE, ALL SUCH OTHER WARRANTIES AND REPRESENTATIONS BEING HEREBY EXPRESSLY DISCLAIMED. NPK SHALL NOT BE LIABLE FOR SPECIAL, INCIDENTAL, OR CONSEQUENTIAL DAMAGES, INCLUDING, WITHOUT LIMITATION, COSTS, LOSSES OR LIABILITIES ON ACCOUNT OF DELAY OR DOWNTIME.**

No person is authorized to grant any other warranties or to assume any other liability on NPK's behalf unless made or assumed in writing by an officer of NPK.

NPK CONSTRUCTION EQUIPMENT, INC., WALTON HILLS, OHIO, U.S.A.
www.npkce.com

May 2023

WARRANTY STATEMENTS

APPLICATION FOR WARRANTY MUST BE MADE WITHIN 30 WORKING DAYS OF FAILURE / REPAIR.

NPK

WARRANTY

"Use Genuine NPK Parts" 1/19

STANDARD DEMOLITION AND ACCESSORY TOOLS

STANDARD DEMOLITION and ACCESSORY TOOLS WARRANTY (30 days)

NPK CONSTRUCTION EQUIPMENT, INC. ("NPK") warrants that new Standard Demolition Tools, and other Standard Accessory Tools sold by NPK will be free from defects in material or workmanship for a period of thirty (30) days, starting from the date of installation. NPK reserves the full right to determine if, and to what extent, warranty adjustments may be made for breakage of the demolition or other accessory tools. **NPK Tool Warranty does not cover labor or travel expenses.**

THIS WARRANTY DOES NOT APPLY TO:

- Custom or special application tools which are excluded from warranty.

NPK RESPONSIBILITY

NPK will, at its option, replace with a new or reconditioned tool, any warranted tool that fails by reason of defective material or workmanship, free of charge delivered at a place of business of an NPK Dealer. Tool breakage is specifically covered ONLY for straight across breakage as shown at locations A.

For warranted tool failures, a prorated credit, up to 80% maximum, will be issued for tools with tip wear greater than 50 mm on chisel andmoil points, or 30 mm on blunt end tools. Note: Parts replaced under warranty become the property of NPK.

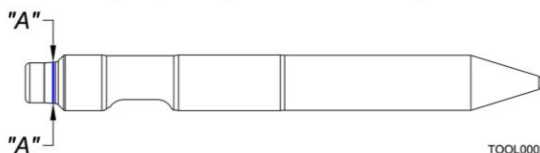

USER RESPONSIBILITY

- Photos and all numbers from retaining pin slot must accompany all warranties submitted to NPK. These photos can be 35 mm, polaroid, or digital.
- The installer, user, operator, repairer, assumes responsibility to read, understand and comply with NPK's written INSTALLATION, OPERATOR and SERVICE INSTRUCTIONS.
- All labor costs.
- Any expense incurred by field repair.
- Tool failures as shown at locations tb. (see NPK Operators Manual for correct operating procedures.)

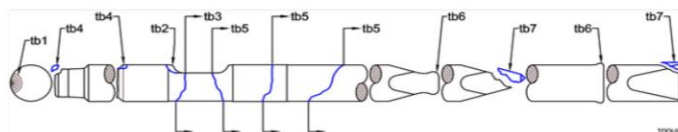

CAUSE OF FAILURE

tb1 - Typical break from bending overload.
 tb2 and tb3 - repeated blank hammering.
 tb3 - bending overload due to excessive wear of the tool bushings.
 tb4 - corner loading due to excessive wear of the tool bushings.

tb5 - bending overload from excessive prying or slant hammering.
 tb6 - deformation from overheating by hammering in the same position for more than 30 seconds.
 tb7 - chipped, due to wrong application, or overheating by hammering in same position for over 30 seconds.

THESE WARRANTIES DO NOT COVER FAILURES RESULTING FROM:

- Installation, alteration, operation, maintenance, repair or storage which NPK judges improper.
- Inadequate lubrication.
- Exceeding the tool and/or tool bushing wear limit.
- Unreasonable delay in making a repair after being notified of a potential product problem.

THESE WARRANTIES SPECIFICALLY EXCLUDE:

- Any tool which is altered, welded, hardfaced or resharpened.
- Replacement due to tip or shank wear.
- Installations not approved by NPK.
- Use of parts not sold by NPK. **THE USE OF "WILL FIT" PARTS WILL VOID ALL NPK WARRANTIES.**
- Parts shipping charges in excess of those which are usual and customary. (Air freight, unless pre-approved, will not be covered.)
- Duties, brokerage fees, and local taxes.

WARRANTY REPAIRS DO NOT EXTEND THE STANDARD WARRANTY PERIOD.

Internet: www.npkce.com

As used in this warranty the term NPK means NPK CONSTRUCTION EQUIPMENT, INC., WALTON HILLS, OHIO, U.S.A.

LIMITATIONS AND EXCLUSIONS

Violation of any federal, provincial, state or local laws, ordinances, rules or regulations, or removal or alteration of product serial numbers void NPK's written product warranties.

Application for warranty must be made within 30 days of failure / repair.

THIS PRODUCT MUST BE USED IN A SAFE AND LAWFUL MANNER IN COMPLIANCE WITH APPLICABLE OSHA REGULATIONS.

The written product warranties made by NPK set forth NPK's only obligations with respect to any claims of failure, defects or deficiencies in products sold by NPK. **NPK MAKES NO OTHER WARRANTIES OR REPRESENTATIONS WHATSOEVER, EXPRESS OR IMPLIED, OF THE QUALITY, PERFORMANCE, DURABILITY, MATERIALS, WORKMANSHIP, SUITABILITY, CONDITION, DESIGN OR UTILITY OF PRODUCTS SOLD BY NPK, INCLUDING WITHOUT LIMITATION, IMPLIED WARRANTIES OF MERCHANTABILITY AND FITNESS, ALL SUCH OTHER WARRANTIES AND REPRESENTATIONS BEING HEREBY EXPRESSLY EXCLUDED. NPK SHALL NOT BE LIABLE FOR SPECIAL, INCIDENTAL OR CONSEQUENTIAL DAMAGES, INCLUDING WITHOUT LIMITATION, COSTS, LOSSES OR LIABILITIES ON ACCOUNT OF DELAY OR DOWNTIME.**

DISCLAIMER REGARDING OTHER REPRESENTATIONS OR WARRANTIES

No person is authorized to grant any other warranties or to assume any other liability on NPK's behalf unless made or assumed in writing by an officer of NPK. No person is authorized to grant any warranties or to assume any liabilities on the seller's behalf unless made or assumed in writing by the seller.

WARRANTY STATEMENTS

"Use Genuine NPK Parts" 6/08

NPK WARRANTY REPLACEMENT PARTS

APPLICATION FOR WARRANTY MUST BE MADE WITHIN 30 WORKING DAYS OF FAILURE / REPAIR.

REPLACEMENT PARTS WARRANTY (90 days)

NPK CONSTRUCTION EQUIPMENT, INC. ("NPK") warrants that new Replacement Parts sold by NPK will be free from defects in material or workmanship for a period of ninety (90) days, starting from the date of installation. NPK Replacement Parts Warranty **does not** cover labor or travel expenses. Note: Unexpired New Product Warranty has priority over Replacement Parts Warranty.

THIS WARRANTY DOES NOT APPLY TO:

- Wear items such as upper and lower tool bushings, impact ring, retaining bars and pins.
- Tools (covered under separate Tool Warranty).

NPK RESPONSIBILITY

NPK will, at its option, repair or replace with a new or reconditioned part, any warranted part that fails by reason of defective material or workmanship, free of charge delivered at a place of business of an NPK Dealer. Note: Parts replaced under warranty become the property of NPK.

USER RESPONSIBILITY

- **Photos must accompany all warranties submitted to NPK. These photos can be 35mm, polaroid, or digital.**
- The installer, user, operator, repairer, assumes responsibility to read, understand and comply with NPK's written INSTALLATION, OPERATOR and SERVICE INSTRUCTIONS.
- All labor costs.
- Any expense incurred by field repair.
- Supplying a hydraulic oil sample from the carrier machine upon request by NPK.

THESE WARRANTIES DO NOT COVER FAILURES RESULTING FROM:

- Installation, alteration, operation, maintenance, repair or storage which NPK judges improper.
- Not performing DAILY VISUAL INSPECTIONS and/or RETIGHTENING of fasteners after initial 20 operating hours after repair.
- Exceeding the tool and/or tool bushing wear limit.
- Underwater operation.
- Operation after discovery of defective or worn parts.
- Unreasonable delay in making a repair after being notified of a potential product problem.

THESE WARRANTIES SPECIFICALLY EXCLUDE:

- Installations not approved by NPK.
- Replacement due to normal wear.
- Use of parts not sold by NPK. **THE USE OF "WILL FIT" PARTS WILL VOID ALL NPK WARRANTIES.**
- Parts shipping charges in excess of those which are usual and customary. (Air freight, unless pre-approved, will not be covered.)
- Duties, brokerage fees, and local taxes.

WARRANTY REPAIRS DO NOT EXTEND THE STANDARD WARRANTY PERIOD.

Internet: www.npkce.com

As used in this warranty the term NPK means NPK CONSTRUCTION EQUIPMENT, INC., WALTON HILLS, OHIO, U.S.A.

LIMITATIONS AND EXCLUSIONS

Violation of any federal, provincial, state or local laws, ordinances, rules or regulations, or removal or alteration of product serial numbers void NPK's written product warranties. **Application for warranty must be made within 30 days of failure / repair.**

THIS PRODUCT MUST BE USED IN A SAFE AND LAWFUL MANNER IN COMPLIANCE WITH APPLICABLE OSHA REGULATIONS.

The written product warranties made by NPK set forth NPK's only obligations with respect to any claims of failure, defects or deficiencies in products sold by NPK. **NPK MAKES NO OTHER WARRANTIES OR REPRESENTATIONS WHATSOEVER, EXPRESS OR IMPLIED, OF THE QUALITY, PERFORMANCE, DURABILITY, MATERIALS, WORKMANSHIP, SUITABILITY, CONDITION, DESIGN OR UTILITY OF PRODUCTS SOLD BY NPK, INCLUDING, WITHOUT LIMITATION, IMPLIED WARRANTIES OF MERCHANTABILITY AND FITNESS, ALL SUCH OTHER WARRANTIES AND REPRESENTATIONS BEING HEREBY EXPRESSLY EXCLUDED. NPK SHALL NOT BE LIABLE FOR SPECIAL, INCIDENTAL OR CONSEQUENTIAL DAMAGES, INCLUDING, WITHOUT LIMITATION, COSTS, LOSSES OR LIABILITIES ON ACCOUNT OF DELAY OR DOWNTIME.**

DISCLAIMER REGARDING OTHER REPRESENTATIONS OR WARRANTIES

No person is authorized to grant any other warranties or to assume any other liability on NPK's behalf unless made or assumed in writing by an officer of NPK. No person is authorized to grant any warranties or to assume any liabilities on the seller's behalf unless made or assumed in writing by the seller.

WARRANTY STATEMENTS

"Use Genuine NPK Parts"

6/08

NPK WARRANTY AUTOLUBE SYSTEM

APPLICATION FOR WARRANTY MUST BE MADE WITHIN 30 WORKING DAYS OF FAILURE / REPAIR.

BASE WARRANTY (6 months)

NPK CONSTRUCTION EQUIPMENT, INC. ("NPK") warrants that new AUTOLUBE assemblies sold by NPK will be free from defects in material or workmanship for a period of six (6) months, starting from the date of delivery to the first user.

MAIN COMPONENT EXTENDED WARRANTY (12 months)

The MAIN COMPONENT EXTENDED WARRANTY covers failure of the MOTOR and DRIVE ASSEMBLY, resulting from defects in material or workmanship in those parts under normal use and service for the period starting with the expiration of the BASE WARRANTY and ends twelve (12) months from the date of delivery to the first user. NPK MAIN COMPONENT EXTENDED WARRANTY **does not** cover labor, travel expenses or the replacement or repair of any other part damaged due to MOTOR or DRIVE ASSEMBLY failure or repair thereof.

THIS WARRANTY DOES NOT APPLY TO:

- REPLACEMENT PARTS, which are covered by other NPK warranties, or hose assemblies and fittings which are not supplied by NPK.

NPK RESPONSIBILITY

NPK will, at its option, repair or replace with a new or reconditioned part, any warranted part that fails by reason of defective material or workmanship, free of charge delivered at a place of business of an NPK Dealer. Note: Parts replaced under warranty become the property of NPK.

During the six (6) month BASE WARRANTY period, NPK will pay the cost of labor at 75% of the posted shop rate that is necessary to install any repaired or replacement warranted part during normal working hours. Overtime rates and travel expenses will not be reimbursed.

USER RESPONSIBILITY

- **Photos must accompany all warranties submitted to NPK. These photos can be 35mm, polaroid, or digital.**
- The installer, user, operator, repairer, assumes responsibility to read, understand and comply with NPK's written INSTRUCTION MANUAL.
- Returning Warranty Registration to NPK at the time of installation.
- All costs associated with shipping the AUTOLUBE unit to an authorized NPK Dealer or other authorized location. NPK is not responsible for any expense incurred in field repair.

THESE WARRANTIES DO NOT COVER FAILURES RESULTING FROM:

- Installation, alteration, operation, maintenance, repair or storage which NPK judges improper.
- Operation after discovery of defective or worn parts.
- Unreasonable delay in making a repair after being notified of a potential product problem.
- Use of grease containing abrasive compounds.
- Contamination.

THESE WARRANTIES SPECIFICALLY EXCLUDE:

- Installations not approved by NPK.
- Replacement due to normal wear.
- Repairs by other than an authorized NPK Dealer.
- Use of parts not sold by NPK. **THE USE OF "WILL FIT" PARTS WILL VOID ALL NPK WARRANTIES.**
- Labor charges that are deemed excessive by NPK.
- Parts shipping charges in excess of those which are usual and customary. (Air freight, unless pre-approved, will not be covered.)
- Duties, brokerage fees, and local taxes.

WARRANTY REPAIRS DO NOT EXTEND THE STANDARD WARRANTY PERIOD.

LIMITATIONS AND EXCLUSIONS

Violation of any federal, provincial, state or local laws, ordinances, rules or regulations, or removal or alteration of product serial numbers void NPK's written product warranties. **Application for warranty must be made within 30 days of failure / repair.**

THIS PRODUCT MUST BE USED IN A SAFE AND LAWFUL MANNER IN COMPLIANCE WITH APPLICABLE OSHA REGULATIONS.

The written product warranties made by NPK set forth NPK's only obligations with respect to any claims of failure, defects or deficiencies in products sold by NPK. **NPK MAKES NO OTHER WARRANTIES OR REPRESENTATIONS WHATSOEVER, EXPRESS OR IMPLIED, OF THE QUALITY, PERFORMANCE, DURABILITY, MATERIALS, WORKMANSHIP, SUITABILITY, CONDITION, DESIGN OR UTILITY OF PRODUCTS SOLD BY NPK, INCLUDING, WITHOUT LIMITATION, IMPLIED WARRANTIES OF MERCHANTABILITY AND FITNESS, ALL SUCH OTHER WARRANTIES AND REPRESENTATIONS BEING HEREBY EXPRESSLY EXCLUDED. NPK SHALL NOT BE LIABLE FOR SPECIAL, INCIDENTAL OR CONSEQUENTIAL DAMAGES, INCLUDING, WITHOUT LIMITATION, COSTS, LOSSES OR LIABILITIES ON ACCOUNT OF DELAY OR DOWNTIME.**

DISCLAIMER REGARDING OTHER REPRESENTATIONS OR WARRANTIES

No person is authorized to grant any other warranties or to assume any other liability on NPK's behalf unless made or assumed in writing by an officer of NPK. No person is authorized to grant any warranties or to assume any liabilities on the seller's behalf unless made or assumed in writing by the seller.

Internet: www.npkce.com

As used in this warranty the term NPK means NPK CONSTRUCTION EQUIPMENT, INC., WALTON HILLS, OHIO, U.S.A.

NOTES AND RECORDS

NPK HYDRAULIC HAMMER MODEL NUMBER _____

SERIAL NUMBER _____

NPK INSTALLATION KIT NUMBER _____

CARRIER MANUFACTURER	
MODEL NUMBER	
SERIES	
SERIAL NUMBER	

DATE OF INSTALLATION _____

DATE OF 20 HOUR INSPECTION _____ WARRANTY REGISTRATION SENT

NPK 7550 INDEPENDENCE DRIVE WALTON HILLS, OHIO 44146
PHONE: 440-232-7900 FAX: 440-232-6294
