



HYDRAULIC HAMMER OPERATORS MANUAL

E SERIES HAMMERS

E208	E220
E210A	E225
E213	E240A
E216	E260A

"Use Genuine NPK Parts"

NPK *...attachments;
designed, built
and backed by NPK.*

7550 Independence Drive
Walton Hills, OH 44146-5541
Phone (440) 232-7900
Toll-free (800) 225-4379
Fax (440) 232-6294

CONTENTS

SAFETY	2
INTRODUCTION.....	4
CARRIER MACHINE COMPATIBILITY	4
HAMMER SPECIFICATIONS	5
HYDRAULIC INSTALLATION	6
PREVENTION OF CONTAMINATION	7
HYDRAULIC QUICK DISCONNECTS	8
MOUNTING INSTALLATION	10
MOUNTING TO THE CARRIER.....	11
REMOVAL FROM THE CARRIER	11
LUBRICATION	12
GREASING PROCEDURE	12
CORRECT GREASE AND GREASE INTERVALS	13
NPK HAMMER GREASE	15
AUTOLUBE SYSTEMS.....	15
AUTOLUBE GREASE LINE PRE-FILLING	16
LUBRICANT TERMS AND DEFINITIONS.....	19
START-UP OPERATION	21
HAMMERS THAT ARE NEW, REBUILT, OR HAVE BEEN INACTIVE	21
BEFORE STARTING THE HAMMER.....	22
DAILY START-UP PROCEDURE	22
OPERATION.....	23
SAFE OPERATING INSTRUCTIONS	23
OPERATING TECHNIQUES & PRECAUTIONS.....	24
ROUTINE INSPECTION AND MAINTENANCE.....	29
TWENTY HOUR INSPECTION.....	30
GAS CHARGE	31
NITROGEN GAS PRESSURE	31
GAS CHARGING KIT	31
CHECKING THE GAS PRESSURE	32
CHARGING THE HAMMER.....	34
DISCHARGING THE GAS PRESSURE	36
TOOLS.....	37
STANDARD TOOLS	37
CHANGING THE TOOL	38
TOOL INSPECTION	39
MAXIMUM TOOL TO TOOL BUSHING CLEARANCE	40
RETAINING PIN.....	41
TIE RODS	42
TIE ROD TORQUE	42
HAMMER FASTENER TORQUE	44
WARRANTY STATEMENTS.....	45
STORAGE OF HYDRAULIC HAMMER	49
NOTES AND RECORDS	50

SAFETY



Safety notices in NPK Instruction Manuals follow ISO and ANSI standards for safety warnings:



DANGER (red) notices indicate an imminently hazardous situation which, if not avoided, **will result in death or serious injury**.



WARNING (orange) notices indicate a potentially hazardous situation which, if not avoided, **could result in death or serious injury**.



CAUTION (yellow) notices indicate a potentially hazardous situation, which, if not avoided, **may result in minor or moderate injury**.



ATTENTION (blue) notices in NPK Instruction Manuals are an NPK standard to alert the reader to situations which, if not avoided, **could result in equipment damage**.

WARNING and BASIC OPERATING INSTRUCTIONS decals are included with each NPK hammer and installation kit. Decals must be installed in the cab, visible to the operator while operating the hammer.

STAY CLEAR, PRESSURE VESSEL, GAS PRESSURE and TOOL SHARPENING decals are installed on all NPK hammer models. Keep them clean and visible. NPK will provide decals free of charge as needed.



1. Operator and Service personnel must read and understand the ***NPK INSTRUCTION MANUAL*** to prevent serious or fatal injury.
2. ***FLYING DEBRIS CAN CAUSE SERIOUS OR FATAL INJURY.***
 - Keep personnel and bystanders clear of hammer while in operation.
 - Do not operate HAMMER without an impact resistant guard between HAMMER and operator. NPK recommends LEXAN® or equivalent material, or steel mesh. Some carrier manufacturers offer demolition guards for their machine. Check with the carrier manufacturer for availability. If not available, please call NPK.



Warning Decal for Cab Installation

3. Do not hardface or sharpen the tool point with a cutting torch. Excessive heat from torching or welding can cause embrittlement, breakage, and flying pieces. Resharpener by milling or grinding only, using sufficient coolant.

SAFETY

CAUTION

4. Fully extend the tool while charging the HAMMER with nitrogen gas. Be sure that the retaining pin is installed. **STAY CLEAR OF TOOL POINT WHILE CHARGING.**
5. Do not disassemble a HAMMER before discharging the hammer gas pre-charge.
6. **USE NITROGEN GAS ONLY!** Store and handle nitrogen tanks per OSHA regulations.
7. Avoid high pressure fluids. Escaping fluid under pressure can penetrate the skin causing serious injury. Relieve pressure before disconnecting hydraulic or other lines.
8. Operate HAMMER from operator's seat only.
9. Match HAMMER size to carrier according to NPK recommendations. The carrier must be stable during hammer operation and during transport.
See CARRIER MACHINE COMPATIBILITY section of the NPK instruction manual.
10. Do not make any alterations to the TOOL without authorization from NPK Engineering.
11. Use proper lifting equipment and tools when handling or servicing the HAMMER.
12. Wear ear protection and safety glasses when operating the hammer. Consult OSHA/MSHA regulations when applicable.
13. Beware of flying metal pieces when driving Boom Pins.
14. If modifications are to be made, **do not alter the HAMMER without authorization from NPK Engineering!**
15. Use only genuine NPK replacement parts. NPK specifically disclaims any responsibility for any damage or injury that results from the use of any tool or parts not sold or approved by NPK.

For further safety information, consult the AEM Hydraulic Mounted Breakers Safety Manual, AEM form MB-140 (NPK P/N H050-9600), which is furnished with every NPK hammer. To request an additional copy, please contact NPK at 800-225-4379 or Internet at www.npkce.com.

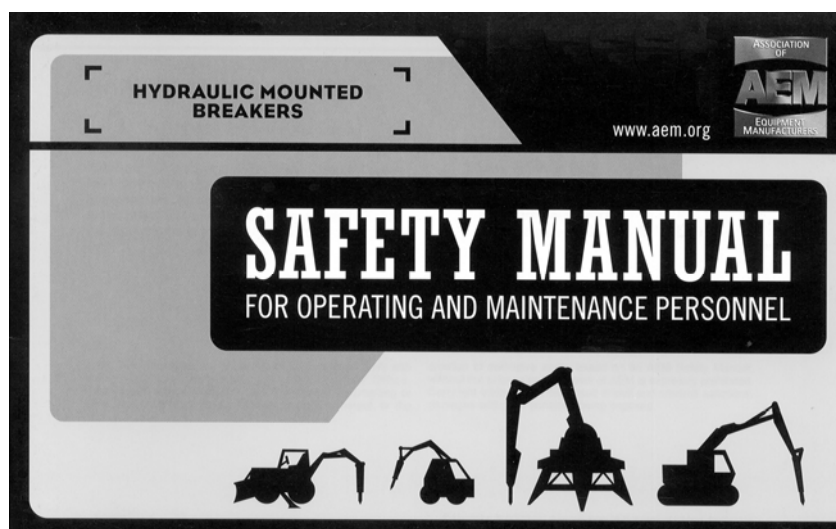

INTRODUCTION

NPK is a leading manufacturer of boom mounted HYDRAULIC HAMMERS, and has the most complete product line available anywhere. The success of NPK is due to our commitment to quality, dependability and long life. The HYDRAULIC HAMMER has many unique designed features and it is a company philosophy that the NPK HYDRAULIC HAMMER can be brought to "like new" condition long after competitive products are scrapped. You can feel confident that you have purchased the best value available.

This comprehensive operator's manual contains instructions for operating and maintaining NPK HYDRAULIC HAMMERS. This manual includes helpful information for obtaining the full potential and efficiency from NPK HYDRAULIC HAMMERS. Please read this manual thoroughly to understand the NPK HAMMER and its operating principles before using it.

For additional information or help with any problem encountered, please contact your NPK authorized dealer.

Whenever repair or replacement of component parts is required, only NPK parts should be used. NPK is not responsible for failures resulting from substitution of parts not sold or approved by NPK.

CARRIER MACHINE COMPATIBILITY

These carrier weight ranges are intended as a guideline only. Other factors, such as stick length, counterweights, undercarriage, etc., must be taken into consideration.



Mounting a HAMMER that is too heavy for the carrier machine can be dangerous and can damage the carrier. Verify carrier stability with HAMMER before transport or operation.

Mounting a HAMMER that is too small for the carrier machine can damage the HAMMER, cause tool breakage and void Warranties. Please consult NPK Engineering for specific detailed information.

CARRIER WEIGHT lbs. (kg)

HAMMER MODEL	RECOMMENDED CARRIER WEIGHT RANGE	
	(lb)	(kg)
E208	28,000 - 42,000	12,700 - 19,000
E210A	40,000 - 56,000	18,000 - 25,000
E213	46,000 - 66,000	20,000 - 30,000
E216	56,000 - 86,000	25,000 - 38,000
E220	66,000 - 100,000	30,000 - 45,000
E225	70,000 - 116,000	32,000 - 52,000
E240A	100,000 - 186,000	45,000 - 85,000
E260A	160,000 - 260,000	73,000 - 120,000

Specifications subject to change without notice.

HAMMER SPECIFICATIONS

HAMMER MODEL	IMPACT ENERGY CLASS ft lb	FREQUENCY bpm	WORKING WEIGHT lbs (Kg)	TOOL	
				DIA in (mm)	WORKING LENGTH in (mm)
E208	2500	430 - 780	2900 (1320)	4.6 (116)	21.5 (550)
E210A	3000	500 - 670	3450 (1565)	5.0 (126)	22 (560)
E213	4000	460 - 590	4200 (1900)	5.4 (136)	23.5 (600)
E216	5500	400 - 500	5650 (2565)	5.7 (146)	25.5 (650)
E220	8000	350 - 430	6800 (3085)	6.1 (156)	27 (685)
E225	12000	300 - 400	7800 (3540)	6.5 (165)	29 (730)
E240A	15000	310 - 390	13000 (5900)	7.2 (184)	32 (815)
E260A	20000	240 - 330	17000 (7710)	8.0 (204)	35.5 (900)

HAMMER MODEL	OIL FLOW		HYDRAULIC OPERATING PRESSURE ¹ psi (bar)	CIRCUIT RELIEF minimum ² psi (bar)	GAS CHARGE PRESSURE	
	gpm	(L/min)			Cold ³ psi (bar)	Hot ⁴ psi (bar)
E208	26 - 48	(100 - 180)	2600 (180)	3100 (215)	390 (27)	450 (31)
E210A	40 - 53	(150 - 200)	2650 (183)	3150 (217)	390 (27)	450 (31)
E213	44 - 55	(165 - 210)	2550 (176)	3050 (210)	350 (24)	405 (28)
E216	45 - 58	(170 - 220)	2500 (172)	3000 (207)	350 (24)	405 (28)
E220	53 - 66	(200 - 250)	2350 (162)	2850 (197)	350 (24)	405 (28)
E225	58 - 77	(220 - 290)	2350 (162)	2850 (197)	365 (25)	420 (29)
E240A	74 - 92	(280 - 350)	2400 (165)	2900 (200)	390 (27)	450 (30)
E260A	79 - 106	(300 - 400)	2400 (165)	2900 (200)	390 (27)	450 (31)

Specifications subject to change without notice.

NOTES:

1. Hydraulic operating pressure maximum is inlet pressure at the hammer with the oil at operating temperature and with the gas charge set at the hot operating pressure. See CHECKING THE HYDRAULIC PRESSURES section in Service Manual.
2. Circuit relief pressure is at least 500 psi (35 bar) above hammer operating pressure.
3. Cold gas charge is the initial set with the hammer at ambient temperature.
4. Hot gas charge is checked after 1 to 2 hours of running and with a system oil temperature of 140° to 180°F (60° to 80°C). This is the preferred check.

HYDRAULIC INSTALLATION

NPK INSTALLATION KITS are available for virtually all compatible backhoe loaders, excavators, and skid steers. Complete parts and instructions for the hydraulic installation of the NPK HYDRAULIC HAMMER including valving and/or controls, hoses and fittings, accumulators, boom and stick tubing, and clamps are provided.

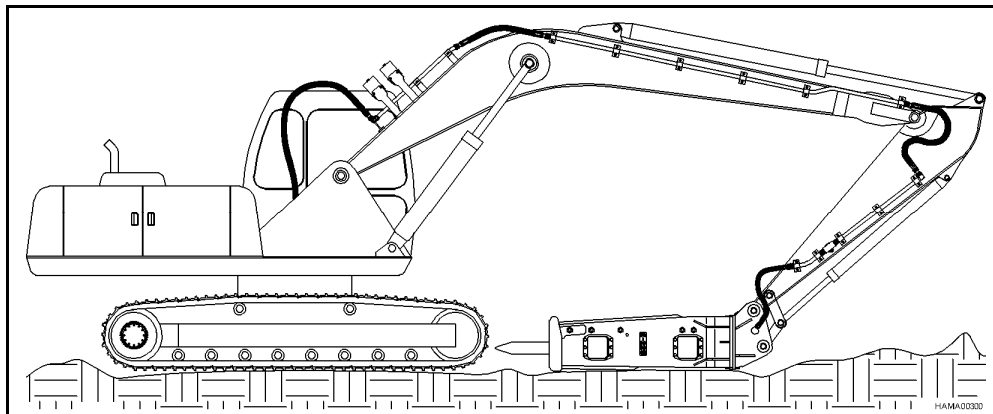

HAMMER LINES

Typically, the pressure line is arranged on the left side of the boom and the return line on the right side. Flow to the hammer is controlled from an auxiliary valve on the carrier or from an NPK supplied valve. Hydraulic oil is routed back to the tank through the carrier's oil cooler and filter.

ACCUMULATORS

General guideline requirements. Some installations may have special requirements.

<i>MODEL</i>	<i>Pressure Line Accumulator</i>	<i>Return Line Accumulator</i>
E208	0	0
E210A, E213, E216	1*	1
E220, E225, E240A, E260A	1*	2

* For gear pump machines only

HAMMER CONTROL VALVE

NPK uses two general types of control systems, depending upon the carrier model:

- CONTROL SYSTEM USING CARRIER AUXILIARY OR SPARE VALVE SECTION.**
This type of installation utilizes an existing carrier valve. Any additional parts, such as a mechanical linkage, hydraulic pilot control valve, flow control valves, etc., are furnished in the NPK HYDRAULIC INSTALLATION KIT. Special hydraulic pressure control valves are not required. The NPK HYDRAULIC HAMMER operating pressure is self-regulating.
- CONTROL SYSTEM USING THE NPK MULTIVALVE.**
For carriers not equipped with a suitable auxiliary or spare valve section, the NPK HYDRAULIC INSTALLATION KIT includes a solenoid operated, priority flow control valve to operate the NPK HYDRAULIC HAMMER. The NPK MULTIVALVE is specifically designed for the operation of boom mounted attachments.

HYDRAULIC INSTALLATION

ATTENTION PREVENTION OF CONTAMINATION

1. A hydraulic hammer is harder on oil than using a bucket, so the oil is apt to deteriorate and breakdown sooner. Neglect of the hydraulic oil can not only damage the hydraulic hammer but also cause problems in the carrier, which could result in damaged components. Care should be taken to check for contamination of the oil and to change it if it is found contaminated. ***Oil sampling at regular intervals is highly recommended.***
 - ❖ When the hydraulic oil shows low viscosity and bubbles, this indicates that the oil is deteriorated. If the oil is dark brown and gives off an offensive odor, it is severely deteriorated. ***Change the oil immediately.***
 - ❖ When the oil is clouded, or the oil filter has become clogged, it indicates that the oil is contaminated. ***Change the oil immediately!***
 - ❖ To change the contaminated hydraulic oil, drain the hydraulic system completely and clean components. Do not mix new oil with the old.
2. Do not allow any contamination to mix with the oil. Take special care in preventing contamination from entering the hydraulic system through the hose or tube connection when changing the hydraulic hammer with the bucket.
3. Low oil level will cause heat build-up, resulting in deterioration of the oil. Also, it may cause cavitation due to air mixing with the oil, leading to a damaged hydraulic hammer and carrier components. Keep the oil at the proper level at all times.
4. Do not use the hydraulic hammer at an operating temperature higher than 180°F (80°C). The proper operating oil temperature range is between 120°F (50°C) and 180°F (80°C). Since clogged cooler fins causes reduced efficiency of the cooler, keep the cooler fins clean at all times. Check the hydraulic oil cooling system to be sure it is working effectively. The use of a heat gun is the best way to evaluate if the cooler is working properly.
5. Water in the hydraulic oil will lead to damage of the hydraulic hammer and carrier. Drain off water and foreign matter from the hydraulic tank at specified intervals. When out of service, the hydraulic hammer should be stored indoors.

CHANGING THE FILTER ELEMENT AND HYDRAULIC OIL

Change the filter element and hydraulic oil at the intervals described in the operation manual of the excavator when using a hydraulic implement. Another method is to set up an oil sampling schedule and change accordingly.

HYDRAULIC INSTALLATION

HYDRAULIC QUICK DISCONNECTS

NPK recommends against the use of non-NPK quick disconnects on hydraulic circuits operating NPK Products.

1. The hydraulic pulsations caused by hydraulic hammer operating can cause internal pieces of non-NPK quick disconnects to disintegrate. These pieces would migrate into the hammer, causing damage.
2. If quick disconnects are used when the hammer is removed from the excavator, the quick disconnects should be capped to keep them clean. If this is not done, contamination on the disconnect will be flushed into the hammer when re-connected. This, again, can cause damage.
3. Most quick disconnects create a restriction in the circuit. NPK Hammers are not back pressure sensitive, but restrictions cause unnecessary heating of the oil. Also, the pressure required to operate the hammer, plus the restriction of the disconnects may push an older, low pressure, carrier machine to the limit of its hydraulic system. This would interfere with proper hammer operation. **However, the NPK approved quick disconnects are properly sized so that the hammer operation is not affected.**

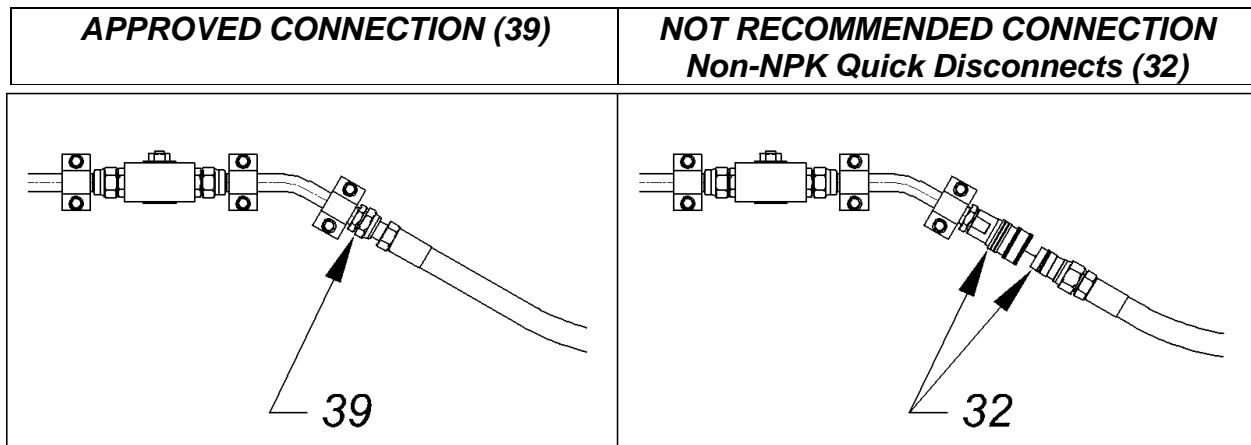

HYDK00004

NPK APPROVED CONNECTION QUICK DISCONNECTS (DX)
CONTACT YOUR NPK DEALER FOR ADDITIONAL INFORMATION ABOUT
NPK QUICK DISCONNECTS

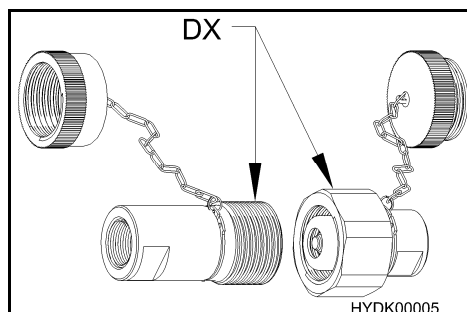

HYDRAULIC INSTALLATION

HYDRAULIC QUICK DISCONNECTS

If hydraulic quick disconnects are used with the NPK Hammer, it is recommended that the following precautions be followed.

1. Periodic inspection of both male (DXm) and female ends (DXf) is recommended to ensure the couplers are in good working condition. Failure to inspect couplers may result in pieces from a damaged or failed coupler to migrate into the hammer or parts of the coupler returned to the machine.
2. Check for dirt, dust, and debris on both couplers before coupling.
3. Be sure that the couplers are completely seated together (38).
4. When replacing couplers, be sure that couplers are replaced as a set, male and female. Do not use one new end and one used end.

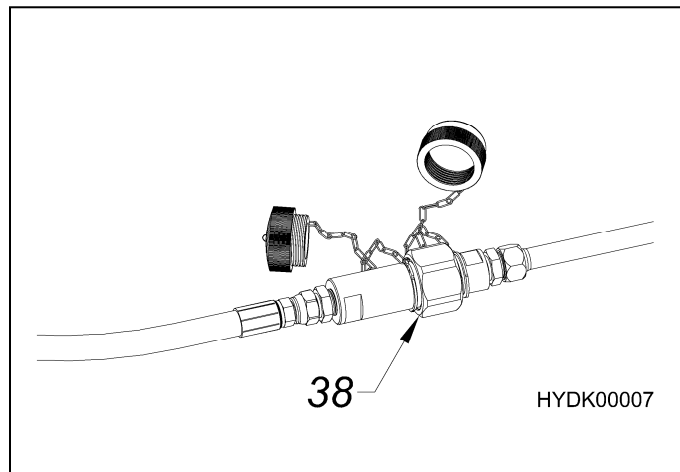
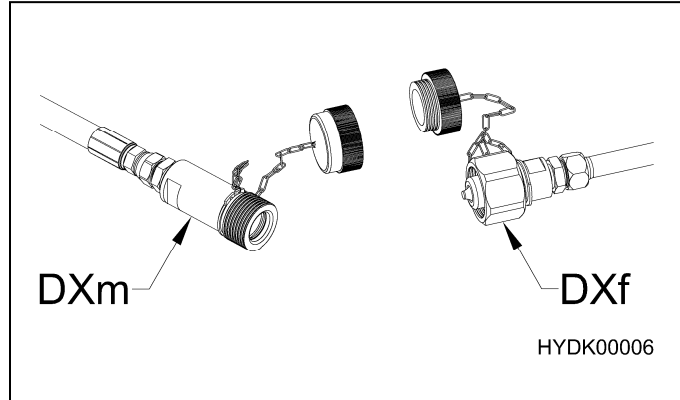

MOUNTING INSTALLATION

NPK Mounting Installation Kits include the parts required to adapt the NPK HYDRAULIC HAMMER to the carrier. NPK mounting kits include the top bracket (m7), flow control valve (if required), and hoses to connect to the carrier hydraulic system.

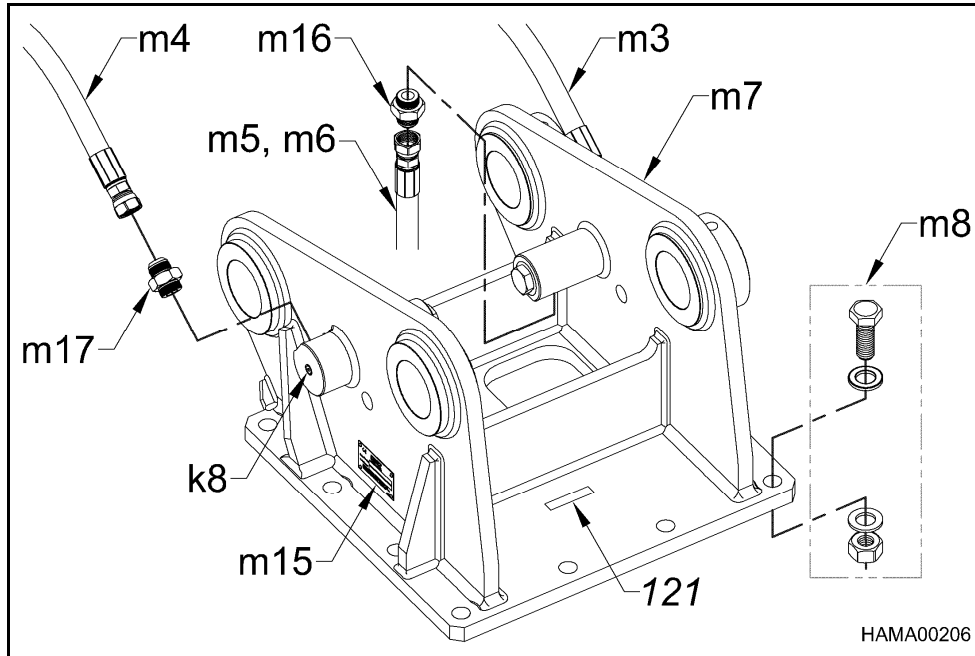

ITEM	DESCRIPTION
k8	TEST PORT
m3	WHIP HOSE (PRESSURE)
m4	WHIP HOSE (RETURN)
m5	HAMMER HOSE (PRESSURE)
m6	HAMMER HOSE (RETURN)
m7	TOP BRACKET
m8	BOLT PACKAGE
m15	I.D. TAG
m16	INSIDE MALE ADAPTER FITTING
m17	OUTSIDE MALE ADAPTER FITTING
121	BRACKET PART NUMBER STAMP

Refer to HAMMER FASTENER TORQUE section for top bracket bolt torque.
Refer to NPK Installation Kit Manual for additional information.

MOUNTING INSTALLATION

MOUNTING TO THE CARRIER

1. Place the hammer horizontal on wood blocks, as shown.
2. Align the boom pin holes. Install the stick pin before the cylinder link pin
3. Clean away any dirt found on the hose connections and connect hoses. Pressure line is on left, return line on right side of boom.
4. Open shut-off valves

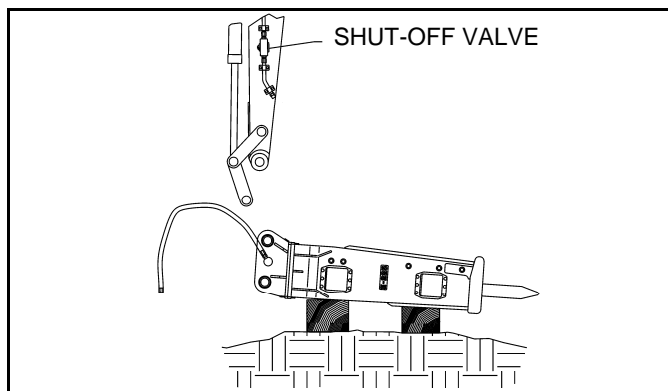

REMOVAL FROM THE CARRIER

ATTENTION

The hydraulic lines must be handled carefully and sealed to prevent contamination from entering the hammer or the carrier hydraulic system.

1. Close pressure and return line shut-off valves.
2. Disconnect the hydraulic hoses before laying the hammer down. **Avoid getting hydraulic oil on rubber mounts. Flush with water if necessary.**
3. Cap the pressure and return lines on the carrier and connect the hammer whip hoses as shown.

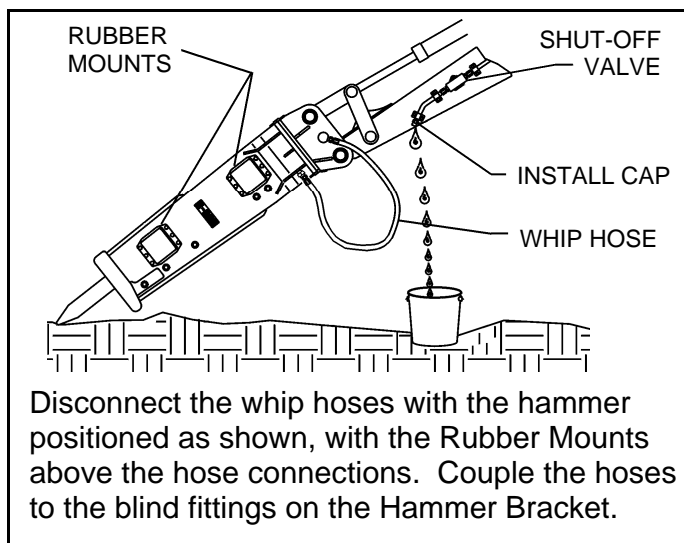

4. Position hammer horizontally on wood blocks and remove the boom pins

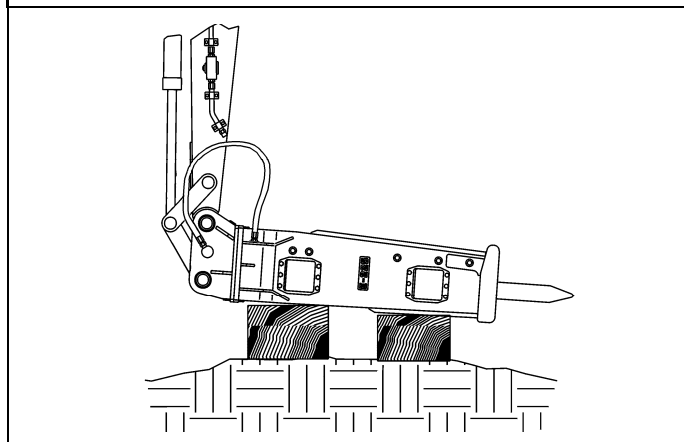

LUBRICATION

GREASING PROCEDURE

Manual greasing for hammers without AUTOLUBE system

IMPORTANT:

1. The hammer must be in a vertical position with downforce applied to push the tool (HH) all the way in. This prevents grease from entering piston impact area.
2. Turn the machine off.
3. Grease the hammer until grease begins to come out around the tool and lower bushing.

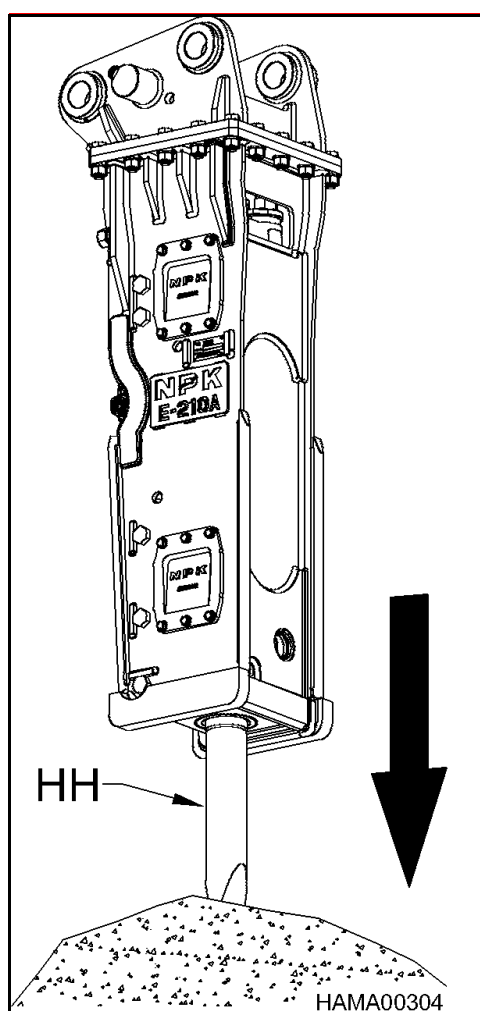

APPLY DOWNFORCE TO PUSH TOOL UP INTO HAMMER

NOTE: USE A GOOD QUALITY EP #2 LITHIUM BASED GREASE WITH WEAR INHIBITING ADDITIVES, SEE PAGES 13, 14, AND 15.

LUBRICATION

CORRECT GREASE AND GREASE INTERVALS

Proper hammer maintenance requires a sufficient supply of the correct grease to the tool (chisel). The tool must be pressed against a hard surface until it stops up inside the hammer. This prevents grease from entering piston impact area and ensures proper distribution of grease between the tool and tool bushings.

GREASE INTERVALS

If the hammer is not connected to an Autolube system, see page 15, the hammer must be greased at regular intervals to get the best life from the tool and tool bushings. There are two ways to determine grease intervals:

First, grease the hammer at the beginning of the job until grease comes out between the tool and the lower tool bushing. Run the hammer until the shank of the tool starts to look dry. This determines the time interval for the greasing of this particular hammer on this particular job. Typically, this is 1 to 4 hours. Also, note the amount of grease needed to re-grease the tool. This gives you the amount of grease and how often it must be applied. An example would be that a particular hammer, on a particular job, requires half a tube of grease every 3 hours. This would be the greasing schedule you would set up. If this hammer was moved to another job, another grease schedule may have to be determined.

Second, if you can't control the grease schedule, such as rental units, then have the operator grease the hammer once every hour of hammer operation. Again, grease the hammer until grease comes out between the tool and tool bushing. This is usually more often than required, but is far cheaper than replacing prematurely worn tools and tool bushings.

CORRECT GREASE

The type of grease used is very important. NPK recommends a lithium soap base EP (Extreme Pressure) NLGI #2 Grease, with Moly (Molybdenum Disulfide) or other surface protecting additives. A high drop point (500° F, 260° C) grease is desirable.

On the following page is a list of commonly available greases, by manufacturer and brand name that meet NPK's recommendations. NPK does not endorse any one brand as being superior to another. If you or your customers use a brand not listed, please call the NPK Service Department at 800-225-4379.

LUBRICATION

CORRECT GREASE FOR HYDRAULIC HAMMERS

MANUFACTURER	BRAND NAME
Amalie Oil Co.	LI-2M
Amoco	Rykotac EP Grease Amolith Grease 94601 Rykon Premium Grease EP (Grade 94108) Rykon Premium Moly Grease (Grade 94114) Amoco Molyolith Grease 92006
Amsoil, Inc.	GHD
BP Oil, Inc.	Bearing Gard-2
Caterpillar	Multipurpose Molybdenum Grease (MPGM)
Cato Oil and Grease Company	Moly Lithflex CX AS
CITGO	Citgo Extra Range Grease
Conoco, Inc.	Super Lube M EP #2
Dryden Oil Company	Moly EP 2
Exxon	Ronex Extra Duty Moly NLGI 2
Fiske Brothers Refining Co. (Lubriplate)	MO-LITH No. 2
John Deere	TY6333/TY6341 Moly High Temp
Kendall	L-424
Mobil	Moly 372
Muscle Products Corporation (MPC)	PL-10 Powerlift Grease LP-10 Lithium EP Plus
NPK	<i>Universal Plus Lithium EP Grease</i> <i>Super Duty EP Grease (water resistant)</i> <i>Chisel Paste</i>
Pennzoil	Adhezolith EP 2 Grease
Phillips 66 Company	Philube MW
Shell	Retinax ® AM Grease 71119
	Retinax ® HD Grease
Standard Oil Company	Bearing Gard-2
Sun Refining & Marketing Company	Prestige Moly 2 EP
Texaco, U.S.A.	Molytex EP 2
Union Oil Company	Unoba Moly HD #2
Unocal	Unoba Moly HD #2

LUBRICATION

CORRECT GREASE FOR HYDRAULIC HAMMERS

NPK HAMMER GREASE

NPK now offers hammer grease specially formulated to meet severe job requirements. The grease is available in three different temperature ranges - 350°, 500°, and 2000°. All are compatible with Autolube systems.

Universal Plus and *Super Duty* are lithium soap based products that resists washout and contain NPK-10 additive for surface protection in friction affected areas.

Chisel Paste is an aluminum complex soap base with 12% graphite and copper additives for extreme operating conditions.

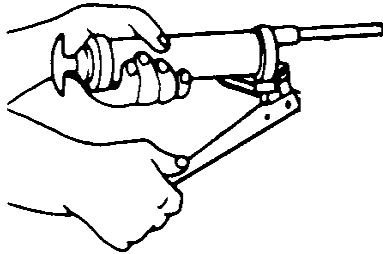

350°	500°	2000°
NPK UNIVERSAL PLUS LITHIUM PLUS EP2 GREASE	NPK SUPER DUTY EP2 GREASE WATER RESISTANT	NPK CHISEL PASTE EP2 GREASE EXTREME TEMP WATER RESISTANT

UNIVERSAL PLUS 350 deg	NPK PART NO.
14 OZ. CARTRIDGE	G000-1010
120 LB. KEG	G000-1020
35 LB. PAIL	G000-1030
400 LB. DRUM	G000-1040

SUPER DUTY 500 deg	NPK PART NO.
14 OZ. CARTRIDGE	G000-1011
120 LB. KEG	G000-1021
35 LB. PAIL	G000-1031
400 LB. DRUM	G000-1041

CHISEL PASTE 2000 deg	NPK PART NO.
14 OZ. CARTRIDGE	G000-1050

AUTOLUBE SYSTEMS

An automatic greasing system is recommended to reduce hammer tool and tool bushing wear. The NPK AUTOLUBE System is designed to automatically provide a continuous supply of grease to the hammer tool and tool bushing – increasing tool and tool bushing life by reducing wear. The AUTOLUBE pump is capable of pumping EP2 grease in cold weather. The pump output is adjustable according to the requirements of the hammer model and to compensate for tool bushing wear.

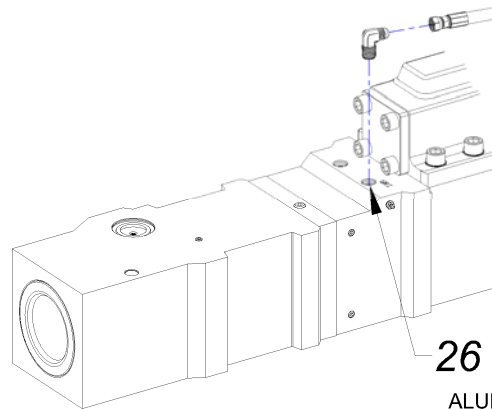

ALUB00084

NPK hammer models E208 and larger have a connection port (26) for an automatic greasing system. Refer to the NPK AUTOLUBE Instruction Manual for details.

LUBRICATION

AUTOLUBE GREASE LINE PRE-FILLING

It is **mandatory** that the supply line from the Autolube main pump to the connection on the hammer is primed with grease before it is used. **Failure** to do this will result in no grease being administered to the hammer tool for **two to three** hours. This can and will result in severe galling of the tool and tool bushing.

PRIMING THE GREASE LINE

1. Place the hammer (KK) in a vertical position, applying enough down force to push the tool up into the hammer.
2. Turn the machine off.
3. Fill the NPK Autolube pump reservoir with a power greaser through the fill fitting on the side of the pump, or from the top by removing the fill cover. Use a premium quality grade EP-2, high temperature grease with wear inhibiting additive.

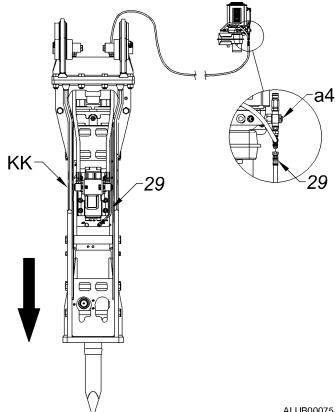
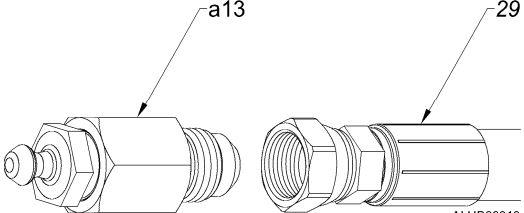
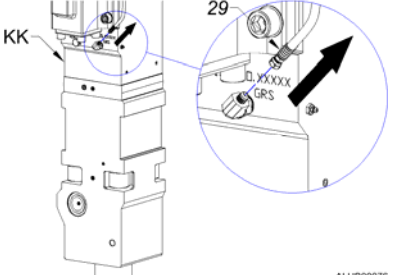
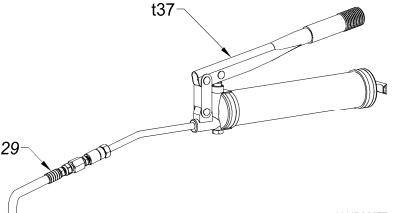
<p>4. Disconnect the grease line (29) from the Autolube main pump cartridge (a4).</p>	 <p style="text-align: right;">ALUB00075</p>
<p>5. Install part number G100-8050 hose fill adapter (a13) onto the #6 JIC end of the grease line (29) previously removed.</p>	 <p style="text-align: right;">ALUB00010</p>
<p>6. Remove the grease line (29) at the hammer (KK).</p>	 <p style="text-align: right;">ALUB00076</p>
<p>7. Attach a grease gun (t37) or power greaser to the grease line (29) leading to the hammer.</p>	 <p style="text-align: right;">ALUB00077</p>

LUBRICATION

AUTOLUBE GREASE LINE PRE-FILLING

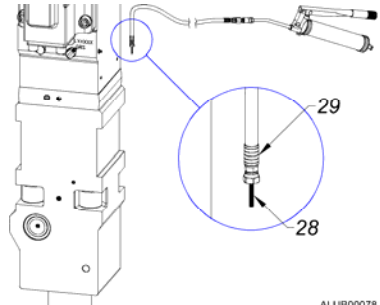
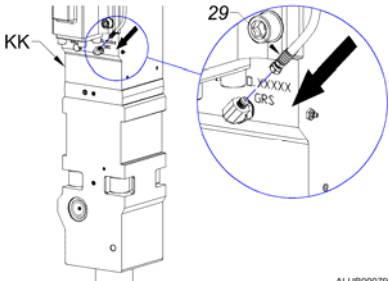
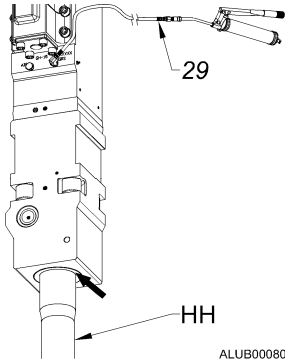
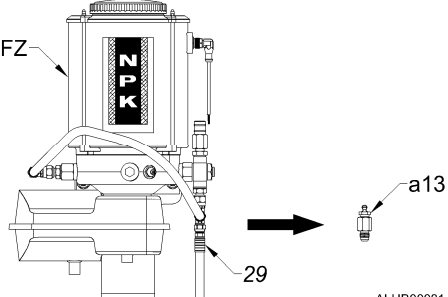
<p>8. Pump grease through the grease line (29) until a steady stream of grease (28) is realized at the opposite (hammer) end.</p>	 <p>ALUB00078</p>
<p>9. Re-attach the grease line (29) to the hammer (KK).</p>	 <p>ALUB00079</p>
<p>10. Pump twenty more shots of grease into the grease line (29). This will prime the hammer cavity and pre-lube the tool. Look for grease coming out around the tool (HH) at the tool bushing (see arrow).</p>	 <p>ALUB00080</p>
<p>11. Remove the hose fill adapter (a13) and re-connect the grease line (29) to the Autolube pump (FZ).</p>	 <p>ALUB00081</p>

NOTE: If the Autolube has run out of grease, the above procedure should be used to purge all the air out of the line before using the hammer. Failure to do this will result in an intermittent supply of grease to the hammer.

LUBRICATION

AUTOLUBE GREASE LINE PRE-FILLING

G100-8050 Hose Fill Assembly

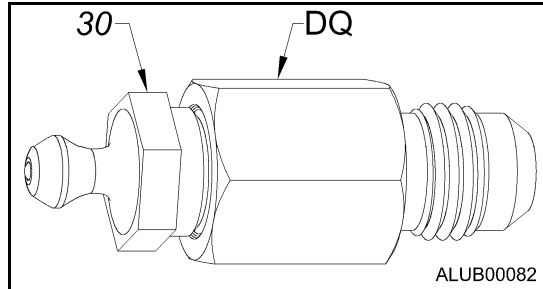

- | | | |
|----|-----------|---|
| 30 | B160-4010 | Grease Fitting – ¼" NPT male |
| DQ | K301-6620 | Male x Female Adapter - #6 JIC male x ¼" NPT female |

LUBRICATION

LUBRICANT TERMS AND DEFINITIONS

TERM	DEFINITION
ADHESIVE	<i>The ability of grease, gear lubricant or oil to cling to metal.</i>
ANTI WEAR AGENTS	<i>Used to help combat metal-to-metal contact, thus reducing wear.</i>
COHESIVE	<i>The ability of grease, gear lube or oil to cling to itself, thus resisting tearing apart.</i>
CONSISTENCY	<i>Consistency of grease is its hardness or firmness. It is determined by the depth in millimeters to which the cone of a penetrometer sinks into a sample under specified conditions. Consistency of grease may be influenced by the type and amount of thickener, viscosity of oil, working and other factors.</i>
CONTAMINATION	<i>Foreign material that could damage a part.</i>
DROPPING POINT	<i>The minimum temperature at which the oil in a grease subjected to heat begins to actually drip and breakdown.</i>
EXTREME PRESSURE AGENTS	<i>Additives that under extreme pressure form an adherent film on metal surfaces, thus forming a film of protection.</i>
FILM STRENGTH	<i>Film strength is defined as the tendency of oil molecules to cling together. It is the ability of those molecules to resist separation under pressure between two metals and to hold these metal surfaces apart.</i>
FRICTION	<i>The resistance to fluid flow in a hydraulic system. (An energy loss in terms of power output.)</i>
GALLING	<i>Surface damage on mating, moving metal parts due to friction. A severe form of adhesive wear.</i>
LUBRICATION	<i>Use of a substance (grease, oil, etc.) to reduce friction between parts or objects that move against each other.</i>
NLGI	<i>A rating given to a grease from the National Lubricating Grease Institute. This rating determines the hardness of the grease and goes on from a 000 to a 6 rating. Most greases are NLGI #2 rated.</i>
OILINESS	<i>Oiliness is measured of the coefficient of friction of a lubricant. Oiliness or lubricity depends on the adhering characteristics of an oil. It is determined by the attraction between the molecules of the oil and the molecules of another material. Of two oils having the same viscosity but different degrees of fluid friction, the one with the lower friction index has the higher degree of oiliness.</i>
PUMP	<i>A device which converts mechanical force into hydraulic fluid power. Basic design types are gear, vane, and piston units.</i>

LUBRICATION

LUBRICANT TERMS AND DEFINITIONS

<i>TERM</i>	<i>DEFINITION</i>
<i>RESERVOIR</i>	<i>A container for keeping a supply of working fluid in a hydraulic system.</i>
<i>VIBRATION</i>	<i>A quivering or trembling motion.</i>
<i>VISCOSITY</i>	<i>Is the actual SAE weight of the product. Example motor oils come in 10, 20, 30, 40, 50 and 15/40 SAE weight. The viscosity designation of a lubricant indicates its internal resistance to flow.</i>

START-UP OPERATION

ATTENTION HAMMERS THAT ARE NEW, REBUILT, OR HAVE BEEN INACTIVE

Before using a new hammer for the first time, the first time after rebuild, or a hammer that has been inactive for a long period of time:

1. Check the nitrogen gas pressure.

The nitrogen gas pre-charge is factory checked before shipment. However, it is recommended the pressure be checked before using the NPK hydraulic hammer for the first time. See CHECKING THE GAS PRESSURE section for procedure.

2. At idle, raise the hammer off of the ground. Place hammer vertical and activate the hammer circuit for 3 – 5 second intervals. Continue for an additional 3 – 4 times to ensure that all the air has been purged from the hoses and hammer before first use. *Failure to do this could result in damage to internal components.*

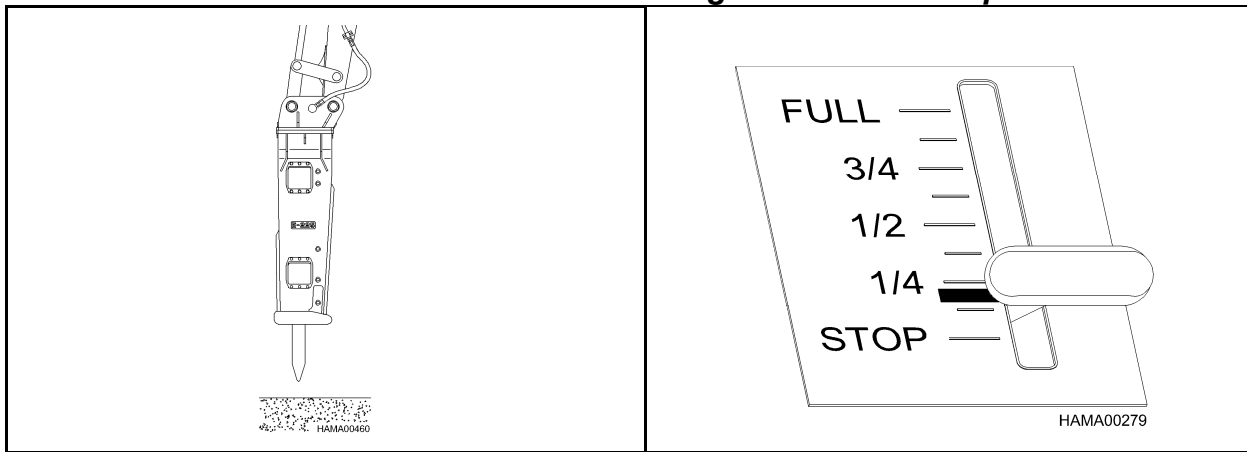

3. Place hammer firmly against material to be broken.

Operate the hammer in a vertical position for approximately 10 minutes at one-half engine speed. Increase engine speed to three-quarters and continue operating at this speed for another 10 to 20 minutes. Increase to full engine speed. Maintain vertical position for the first hour of operation.

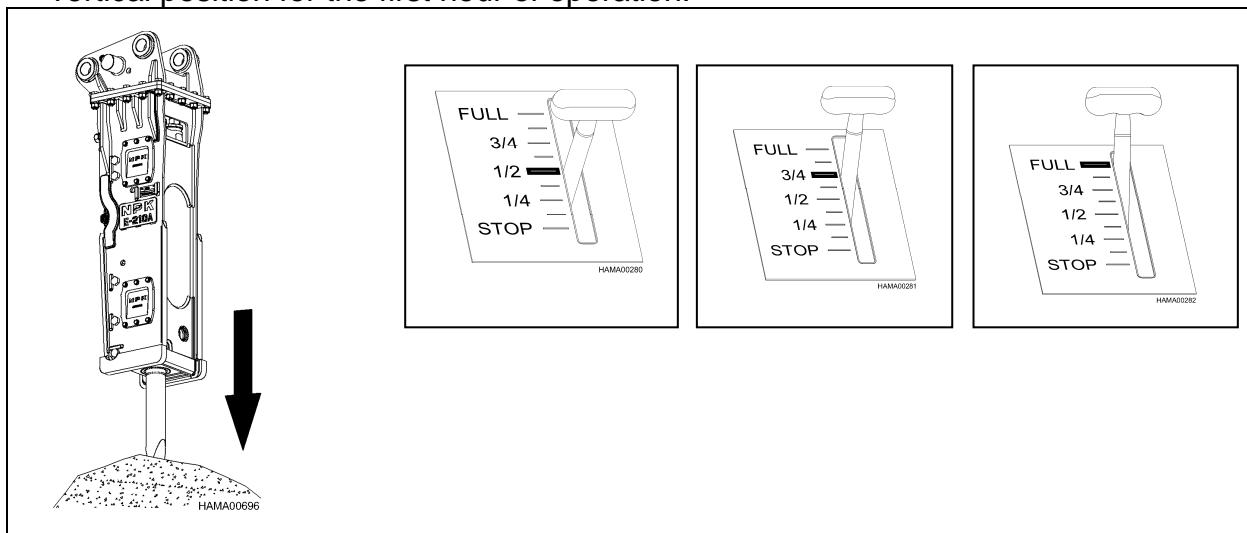

START-UP OPERATION

ATTENTION BEFORE STARTING THE HAMMER

PRE-OPERATION INSPECTION AND WARM UP

Before operating the NPK hydraulic hammer, be sure to perform the specified routine inspection in the ROUTINE INSPECTION AND MAINTENANCE section of this manual.

Warm up the NPK hydraulic hammer, see below, and the carrier machine in accordance with the machine manufacturer's instruction manual. This is especially important during cold weather operation.

DAILY START-UP PROCEDURE

Operate the NPK hydraulic hammer in the vertical position, at 1/2 engine throttle setting, for about 1-2 minutes. During this period, inspect the NPK hydraulic hammer and installation kit for leaks or loose connections.

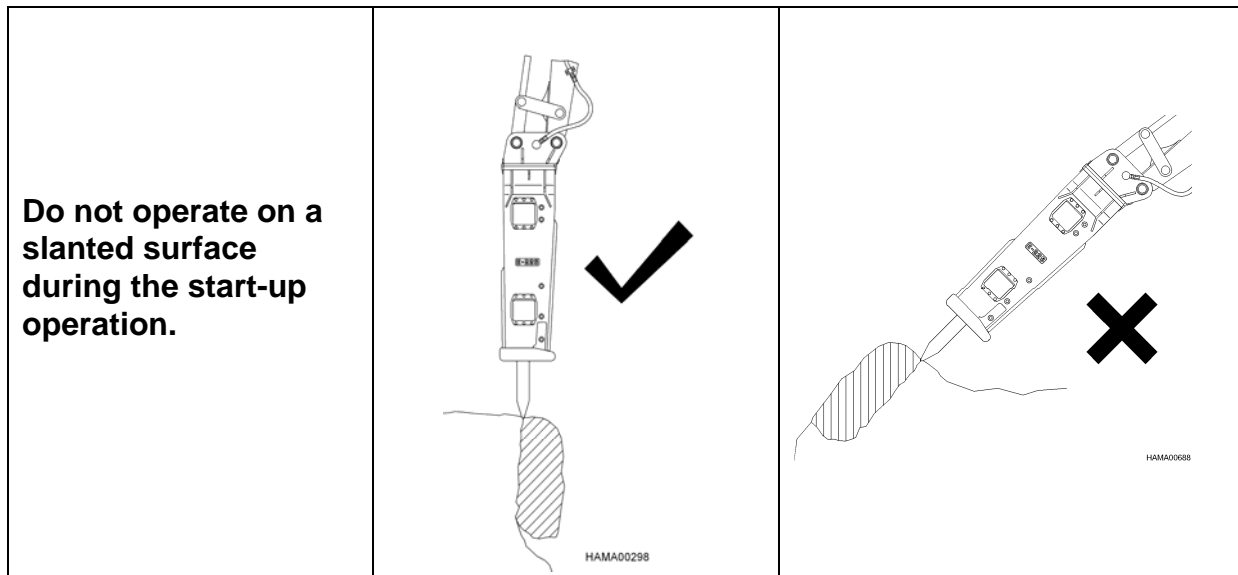

OPERATION

⚠ WARNING SAFE OPERATING INSTRUCTIONS

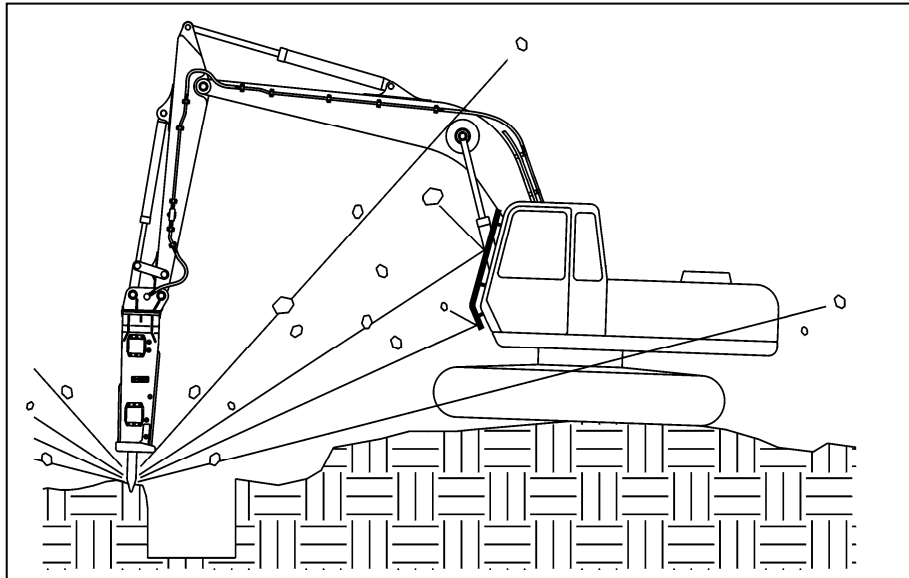

DO NOT OPERATE THE HAMMER WITHOUT AN IMPACT RESISTANT CAB WINDOW OR SHIELD IN PLACE

BEWARE OF FLYING DEBRIS FROM THE HAMMER TOOL POINT

An impact resistant cab window or shield must be in place to protect the operator.

⚠ CAUTION

DO NOT USE THE HAMMER AS A HOIST

The hammer is not intended to lift an object. To do so, can be dangerous.

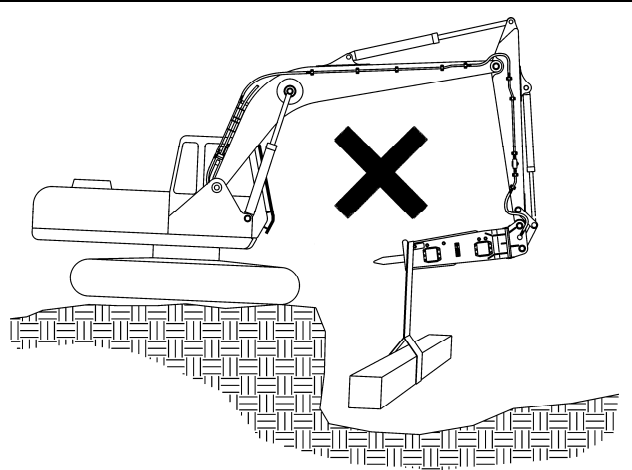

DO NOT TOUCH HOT TOOL AFTER USING!

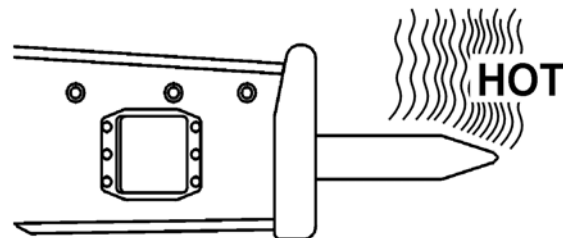

OPERATION

ATTENTION OPERATING TECHNIQUES & PRECAUTIONS

PRELOAD THE TOOL BEFORE STARTING

Press the tip of the demolition tool vertically against the object to be broken. Be sure the object is stable before activating the NPK HYDRAULIC HAMMER.

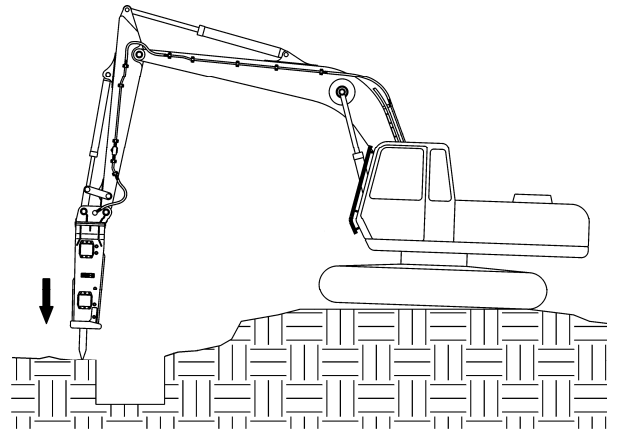

APPLY DOWNFORCE ON THE TOOL

Raise the front of the machine slightly by applying downforce on the demolition tool. Press the control lever or the foot pedal to start the NPK HYDRAULIC HAMMER.

Applying excessive force to the hammer will raise the carrier too high and jolt the operator when the material breaks. Let the NPK HYDRAULIC HAMMER do the work.

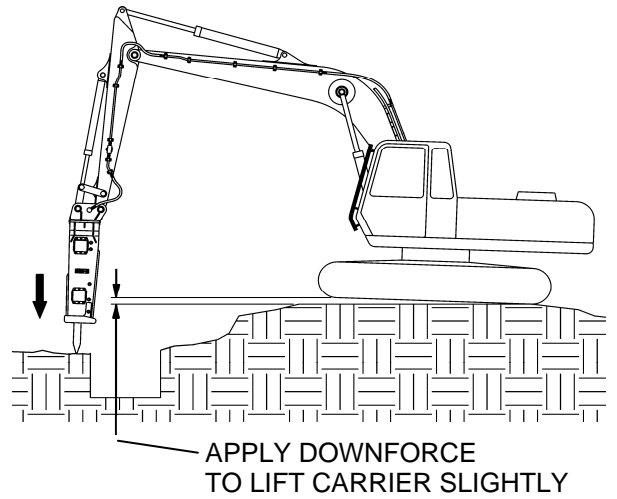

AVOID BLANK HAMMERING

As soon as the material is broken, release the control lever or pedal to prevent unnecessary blank hammering.

Blank hammering is continued hammer operation after the material is broken. This will overheat the hydraulic system and cause undue wear.

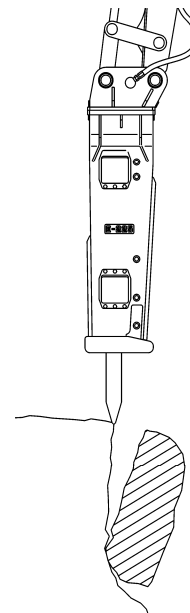

OPERATION

ATTENTION OPERATING TECHNIQUES & PRECAUTIONS

DO NOT SLANT HAMMER

For the most efficient demolition, align the direction of force (51) from the boom with the penetration direction (52) of the tool (HH). Failure to do this decreases the transfer of energy from the piston to the rock and increases the bending forces at the fulcrum of the tool. This unnecessary added stress leads to the following problems:

1. Premature bushing wear and/or tool breakage.
2. Breakage of tie rods.
3. Breakage of bracket bolts.
4. Decrease in transfer of energy translates to reduced production.

When the tool binds from incorrect working angle, the sound of the hammer changes.

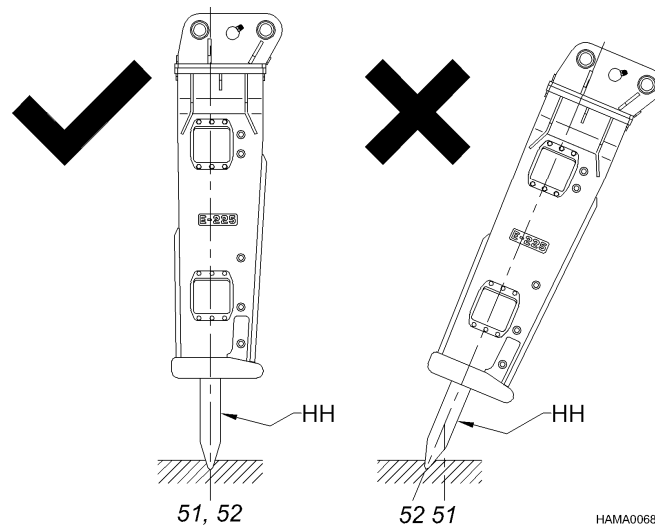

Keep the boom direction of force in the same direction the tool is penetrating. Use the boom cylinder to preload the hammer (apply downforce), and use the bucket and stick cylinders for alignment. Keep the tool tangent to the arc of the boom.

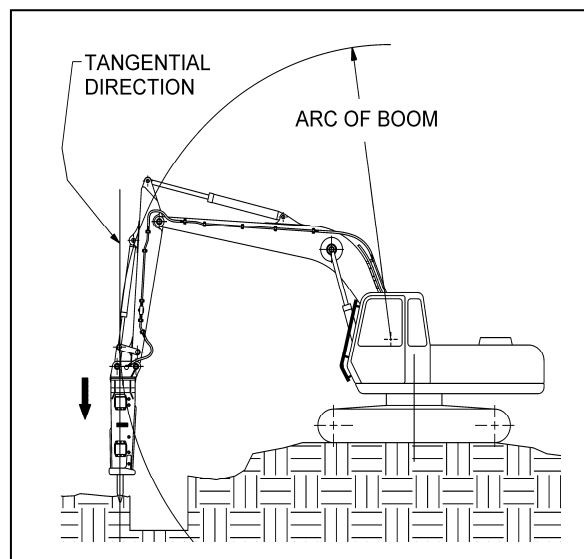

OPERATION

ATTENTION OPERATING TECHNIQUES & PRECAUTIONS

DO NOT USE THE HAMMER TOOL AS A PRY BAR

Excessive prying can cause premature bushing wear and tool or tie rod breakage. When hammering materials that allow the tool to penetrate before breaking, move the hammer slightly fore and aft to create a cone-shaped hole. The vented hole allows trapped dust and heat to escape, increases the tool penetration rate into the material, and prevents overheating the tool tip.

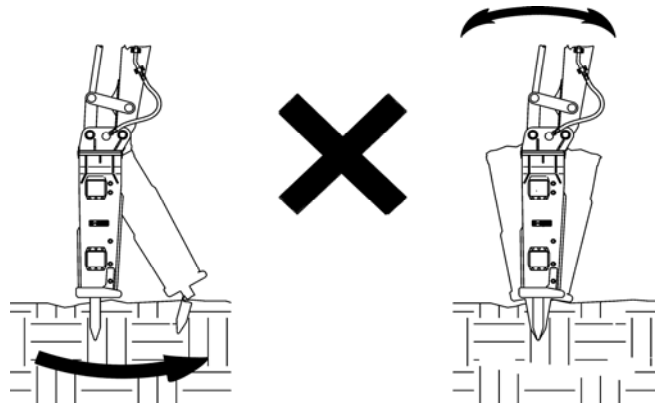

DO NOT HAMMER CONTINUOUSLY IN THE SAME POSITION FOR MORE THAN 30 SECONDS

If the tool cannot break or penetrate into the material after hammering in the same position for 30 seconds, change the working location. Hammering in the same position for a long time will reduce the working efficiency, increase the hydraulic oil temperature, overheat the tool tip and accelerate tool wear.

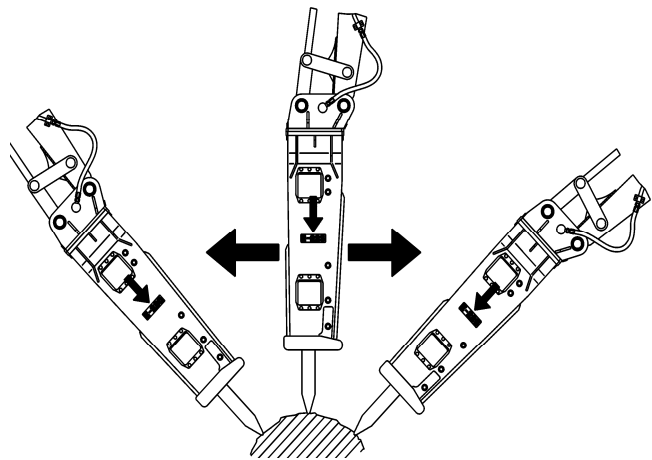

ALWAYS WORK BY BREAKING TO A FREE FACE

The material must have somewhere to break to. Start at an edge.

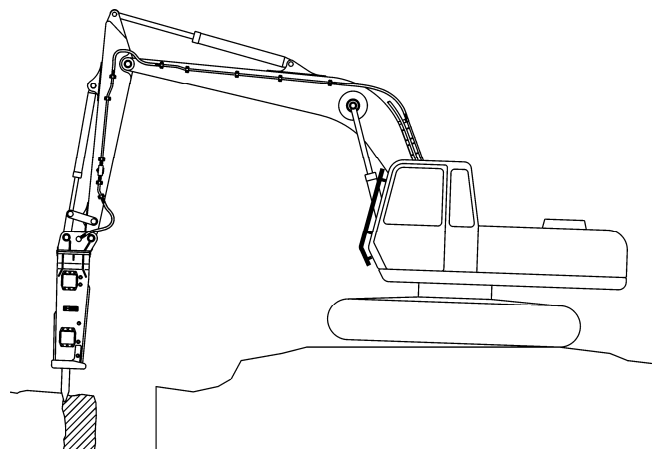

OPERATION

ATTENTION OPERATING TECHNIQUES & PRECAUTIONS

DO NOT DROP THE HAMMER RAPIDLY ON AN OBJECT

Remember, the hydraulic hammer is heavier than an empty bucket and will move faster than expected.

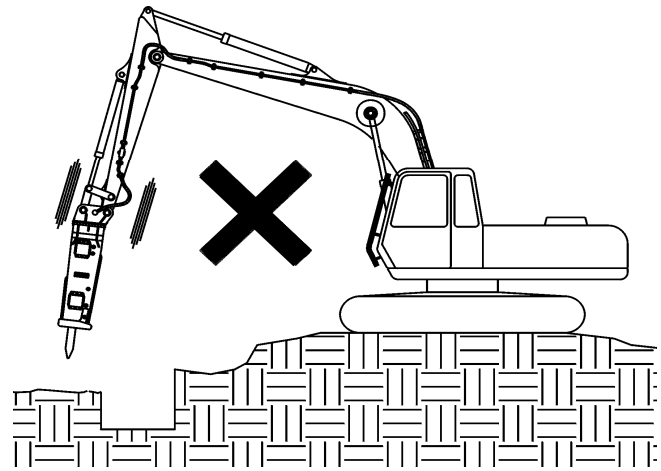

DO NOT USE THE HAMMER OR BRACKET TO MOVE LARGE OBJECTS

Do not use the hammer bracket for purposes other than for what it was intended.

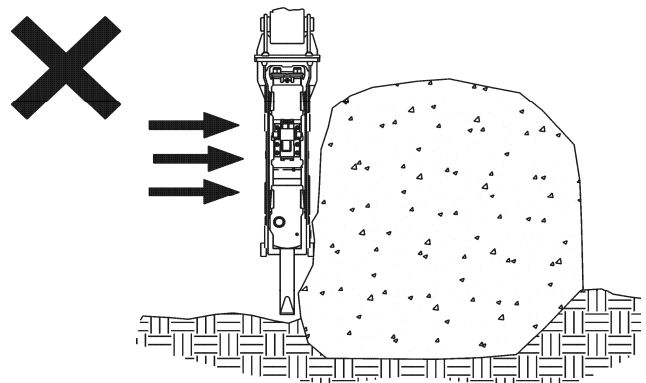

AVOID OPERATING THE HAMMER WITH CYLINDERS AT THE END OF STROKE

Continuous operation with the boom cylinders fully retracted or extended may damage the hydraulic cylinders.

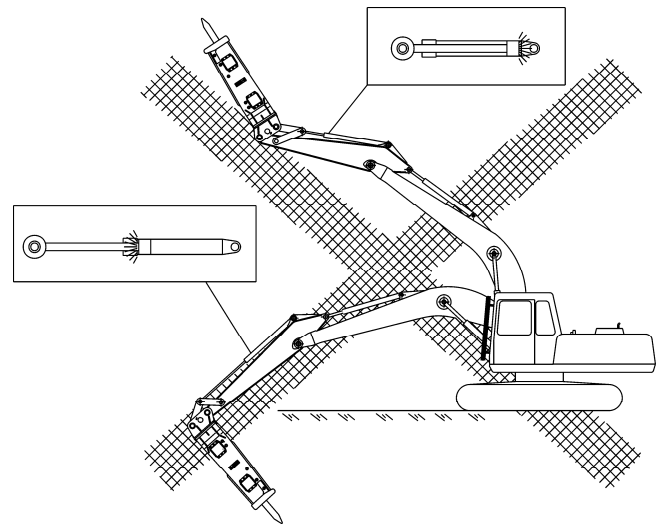

OPERATION

ATTENTION OPERATING TECHNIQUES & PRECAUTIONS

DO NOT OPERATE HAMMER UNDERWATER UNLESS HAMMER HAS BEEN MODIFIED WITH UNDERWATER KIT.

Do not allow parts, other than the tool, to be submerged in water. Underwater operation will damage the hammer and allow water to enter the hydraulic system. The hammer can be modified for underwater operation - contact the NPK Dealer for more information.

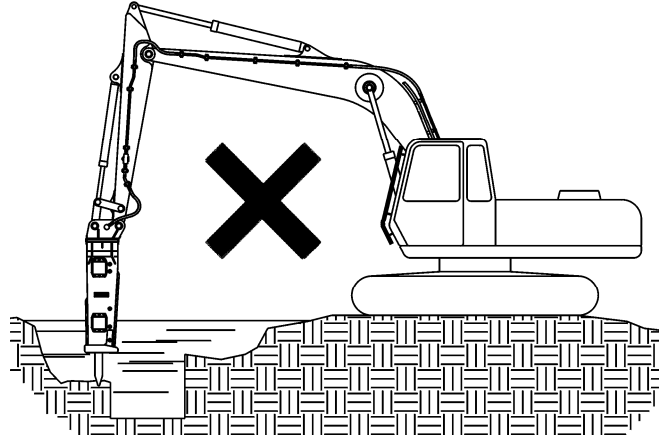

DO NOT SUBMERGE A HOT TOOL IN WATER!

The tip of the tool may be hot from operation. Submerging in water can cause the tip of the tool to become brittle and break prematurely.

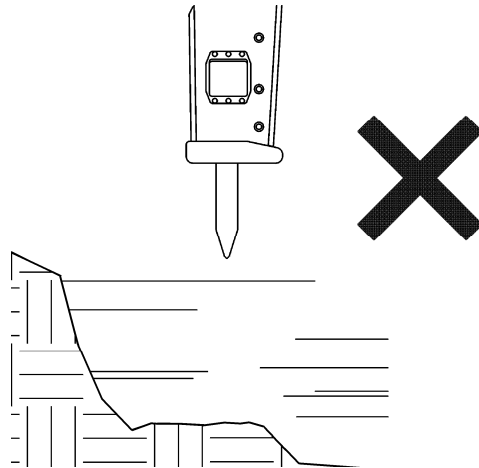

DO NOT ALLOW THE HAMMER TOOL TO HIT THE BOOM

Use caution when tucking the hammer in tight to the boom for transportation.

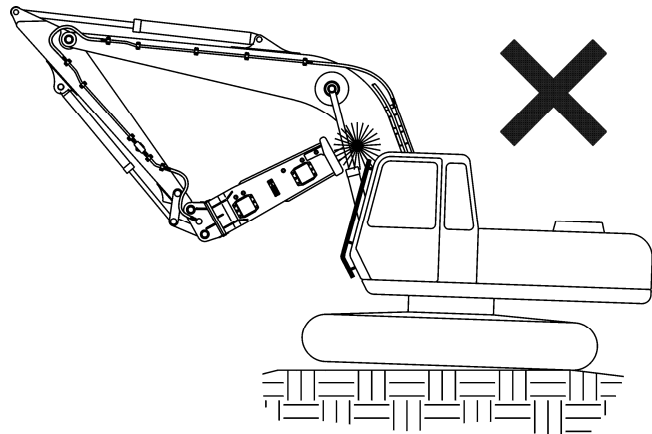

ROUTINE INSPECTION AND MAINTENANCE

1. VISUAL INSPECTION

Detect a potential problem early.

FASTENERS

Inspect all fasteners. Retighten as necessary. Refer to HAMMER FASTENER TORQUE section for Top Bracket bolt torque.

WELDS

Check for cracks, repair as necessary.

HOSES AND TUBING

Check for oil leaks, loose clamps and hose abrasion.

HYDRAULIC OIL

MAINTAIN A CLEAN HYDRAULIC SYSTEM

If non-petroleum oil is used, contact NPK Service Department for compatibility.

Keep hoses clean and capped when dismounting or storing hammer.

Change oil and filters as recommended by carrier manufacturer. Periodic oil sampling is recommended.

2. DEMOLITION TOOL LUBRICATION

Important: It is imperative that grease is maintained in the tool bushing contact area at all times. This may require hourly greasing depending on job conditions.

Important: The hammer must be in a vertical position with downforce applied to push the tool (HH) all the way in. This prevents grease from entering piston impact area. ***Pump grease into hammer until grease is seen coming out between the tool and bushing.***

Use a good quality, high temperature EP#2 grease containing anti-wear additives, see LUBRICATION section.

If machine is equipped with an AUTOLUBE System, check grease reservoir daily.

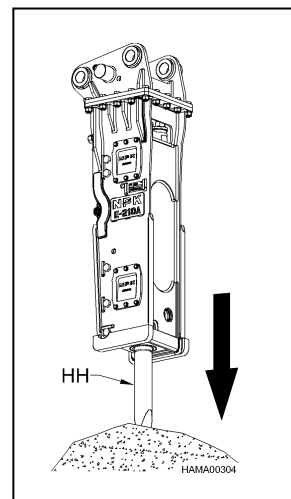

3. TOOL and TOOL BUSHING WEAR

Check the tool and tool bushings for damage, wear or deformation on a regular weekly basis. Replace the tool and/or bushings when wear exceeds the maximum clearance limit, see MAXIMUM TOOL TO TOOL BUSHING CLEARANCE section.

WARNING

Do not hardface or sharpen the tool point with a cutting torch. Excessive heat from torching or welding causes embrittlement, breakage, and flying pieces. Resharpen only with a surface grinder or milling machine using sufficient cooling.

Please consult your authorized NPK Dealer or NPK Service Department for additional information.

TWENTY HOUR INSPECTION

1. WARRANTY REGISTRATION

Complete and send to NPK after initial 20 hour inspection.

2. WELDS

Check for cracks, repair as necessary. ***Consult your authorized NPK Dealer or NPK Service Department for additional information.***

3. TOOL RETAINING PIN

Remove the retaining pin and inspect for peening caused by excessive blank hammering. If necessary, grind edges smooth as shown in TOOL RETAINING PIN INSPECTION section. The retaining pin must rotate freely.

4. DEMOLITION TOOL

Remove the demolition tool and inspect for peening caused by excessive blank hammering. If necessary, grind edges smooth as shown in TOOL INSPECTION, section.

5. GAS CHARGE

Check and adjust, if required, see GAS CHARGE section.

GAS CHARGE

NITROGEN GAS PRESSURE

The nitrogen gas pressure must be measured with no preload on the tool. Remove the tool; or position the hammer with the tool fully extended against the tool retaining pin. The hammer must not be resting vertical on the tool. The gas pressure in the hammer will vary according to the gas temperature.

PREFERRED METHOD

The preferred method to measure or charge the nitrogen gas pressure is with the hydraulic system temperature stabilized at maximum operating temperature. The chart showing values for **“Operating Temperature”** should be used, see below.

ALTERNATE METHOD

The nitrogen gas pressure can be measured or charged at ambient temperature (cold), before operating the hammer. See the chart **“Ambient Temperature”** below.

ATTENTION DO NOT OVERCHARGE THE HAMMER!

Exceeding the gas pre-charge specifications can result in damaging hammer components. The NPK WARRANTY does not cover failures resulting from exceeding the specified nitrogen gas pressure.

NITROGEN GAS PRE-CHARGE SPECIFICATIONS

MODEL	AT AMBIENT TEMPERATURE (cold, before operating) PSI (BAR) (plus 0, minus 25)	AT OPERATING TEMPERATURE PSI (BAR) (plus 0, minus 25)
E208 E210A	390 (27)	450 (31)
E213 E216 E220	350 (24)	405 (28)
E225	365 (25)	420 (29)
E240A E260A	390 (27)	450 (31)

GAS CHARGING KIT

ALL NPK HYDRAULIC HAMMERS are furnished with the following gas charging kit. In addition, a nitrogen tank and pressure regulator valve (not furnished with the hammer) are required. These can be obtained from your local welding supply house. A regulator valve is available from NPK.

<p style="text-align: right; font-size: small;">HAMA00025</p>	<p>GAS CHARGE KIT (PART NO. 7300588)</p> <ul style="list-style-type: none"> g1. Charge Adapter (Part No. 30604040) g3. Plug (Part No. 30102050) g4. Hose (Part No. 20118010) g5. Charging Kit Box (Part No. 35001030) g6. Cap (Part No. 30100500) g7. Optional Regulator Valve (Part No. 21101060)
---	---

GAS CHARGE

CHECKING THE GAS PRESSURE

Inspect the nitrogen gas pressure every 100 hours.

PROCEDURE

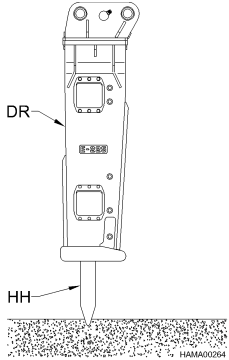
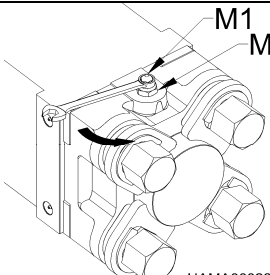
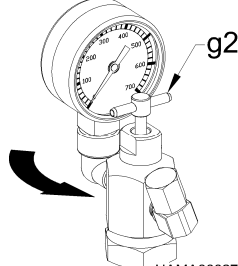
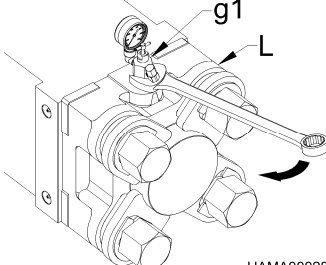
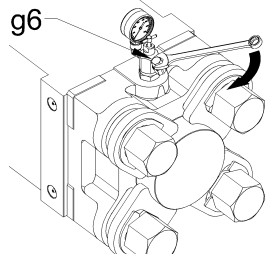
<p>1. The gas pre-charge is measured with no pre-load on the tool (HH). Remove the tool or position the hammer (DR) with the tool fully extended.</p>	 <p>A vertical diagram of a hammer tool. The upper part is labeled 'DR' and the lower part is labeled 'HH'. The tool is shown with a textured ground surface below it. A small code 'HAMA00024' is visible at the bottom right of the diagram.</p>
<p>2. Remove the charge valve cap (M1) from the hammer charge valve (M). Do not remove the charge valve assembly!</p>	 <p>A perspective view of the hammer's internal valve assembly. A cap labeled 'M1' is being removed from a valve labeled 'M'. A curved arrow indicates the removal direction. A small code 'HAMA00026' is visible at the bottom right of the diagram.</p>
<p>3. Turn the NPK charge adapter T-handle (g2) to a full counterclockwise position.</p>	 <p>A close-up of a pressure gauge with a T-handle labeled 'g2'. A curved arrow indicates the handle being turned counterclockwise. A small code 'HAMA00027' is visible at the bottom right of the diagram.</p>
<p>4. Install the NPK charge adapter (g1) onto the hammer charge valve located on the hammer gas head (L).</p>	 <p>A perspective view of the hammer's internal valve assembly. A charge adapter labeled 'g1' is being installed onto a valve labeled 'L'. A curved arrow indicates the installation direction. A small code 'HAMA00028' is visible at the bottom right of the diagram.</p>
<p>5. Tighten the charge adapter cap (g6).</p>	 <p>A perspective view of the hammer's internal valve assembly. A cap labeled 'g6' is being tightened onto the charge adapter. A curved arrow indicates the tightening direction. A small code 'HAMA00029' is visible at the bottom right of the diagram.</p>

GAS CHARGE

CHECKING THE GAS PRESSURE

6. Turn the T-handle (g2) clockwise. As the T-handle is screwed in, a resistance is encountered. By turning the T-handle further, the nitrogen gas pressure will be indicated on the pressure gauge (g8). Stop turning the T-handle when the gauge reads pressure. ***Do not over tighten!***

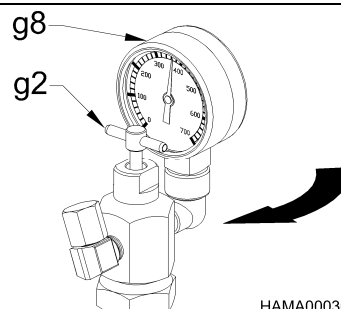

7. Compare the gauge pressure with the NITROGEN GAS PRE-CHARGE chart in the NITROGEN GAS PRESSURE section. If the gas is 25 psi (2 bar) or more below the specification, proceed to the NITROGEN GAS CHARGING PROCEDURE section of the manual. If the pressure is correct, go to the next step.
8. Turn the T-handle counterclockwise until it stops, as in step 3.
9. Slowly loosen the charge adapter cap to relieve the nitrogen gas pressure trapped in the charge valve.
10. Remove the charge adapter from the hammer charge valve.
11. Replace the charge valve cap on the charge valve.

GAS CHARGE

CHARGING THE HAMMER

CAUTION USE NITROGEN GAS ONLY.

STAY CLEAR OF THE TOOL WHILE CHARGING THE HAMMER WITH GAS. The tool may be impacted by the piston and forced out abruptly.

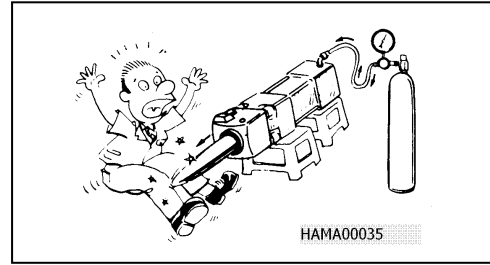

PROCEDURE

1. Carry out steps 1 thru 4 of CHECKING THE GAS PRESSURE.

<p>2. Install a pressure regulator (g7) on a tank (g9) of nitrogen gas.</p>	
<p>3. Connect a hose (g4) from the pressure regulator (g7) on the nitrogen tank (g9) to the charge adapter (g1).</p> <p>4. Turn the T-handle (g2) on the charge adapter (g1) clockwise.</p>	
<p>5. Turn the handle (g7) on the tank regulator counterclockwise to a fully closed position. Do not over tighten!</p> <p>6. Open the valve (g10) on the nitrogen tank (g9) by turning the handle counterclockwise.</p>	
<p>7. Slowly adjust the regulator on the nitrogen tank to the correct pressure by turning the handle clockwise. Refer to the NITROGEN GAS PRE-CHARGE chart in the NITROGEN GAS PRESSURE SECTION.</p>	
<p>8. Charge the nitrogen gas, per the gas charge decal (g11), until the pressure gauge (g8) on the charge adapter (g1) is at the correct setting, then turn the T-handle (g2) counterclockwise all the way out.</p> <p>9. Close the nitrogen tank valve (g10), and then remove the hose (g4) from the charge adapter (g1).</p>	

GAS CHARGE

CHARGING THE HAMMER



Nitrogen gas may be trapped in the hose. Loosen fittings slowly to release pressure!

10. Remove the charge adapter from the hammer charge valve.
11. Replace the charge valve cap.

GAS CHARGE

DISCHARGING THE GAS PRESSURE

PROCEDURE

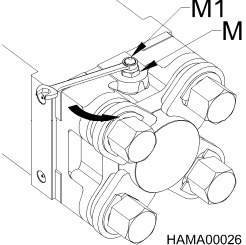
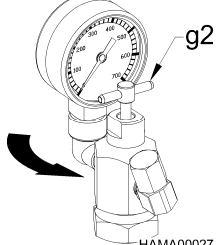
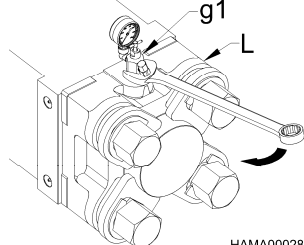
 <p>HAMA00026</p>	 <p>HAMA00027</p>	 <p>HAMA00028</p>
<p>1. Remove the charge valve cap (M1) from the charge valve (M). Do not remove the charge valve assembly!</p>	<p>2. Turn the NPK charge adapter T-handle (g2) to a full counterclockwise position.</p>	<p>3. Install the NPK charge adapter (g1) onto the hammer charge valve located on the hammer gas head (L).</p>

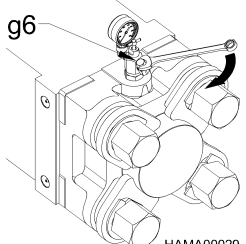
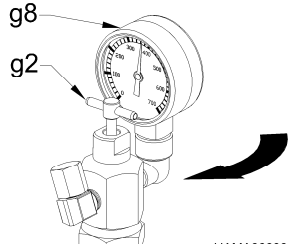
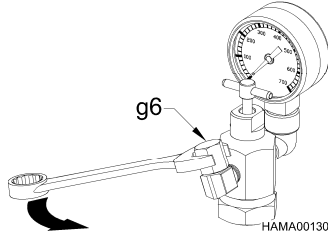
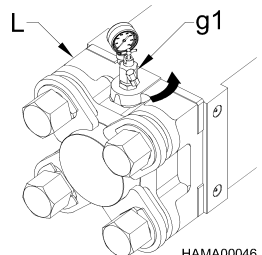

Remove the valve cap only, not the charge valve assembly!

 <p>HAMA00029</p>	 <p>HAMA00030</p>	 <p>HAMA00130</p>
<p>4. Tighten the charge adapter cap (g6).</p>	<p>5. Turn the T-handle (g2) clockwise. As the T-handle is screwed in, a resistance is encountered. By turning the T-handle, the nitrogen gas pressure will be indicated on the pressure gauge (g8). Stop turning the T-handle when the gauge reads pressure. Do not over tighten!</p>	<p>6. Loosen the charge adapter cap (g6) VERY SLOWLY! The gas pressure will gradually decrease to zero. When it gets to zero, remove the cap.</p>  <p>HAMA00046</p>

7. Remove the charge adapter (g1) from the gas charge valve on the hammer gas head (L), then reinstall the charge valve cap.

TOOLS

STANDARD TOOLS

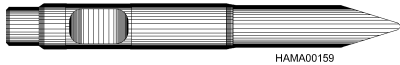
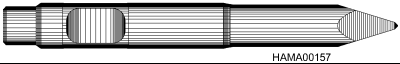
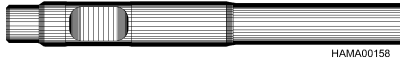
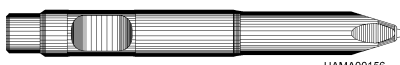
<i>DEMOLITION TOOL</i>	<i>SHAPE</i>	<i>APPLICATIONS</i>
CHISEL Crosscut (FX)		<ul style="list-style-type: none"> • Controlled breakage of concrete • Layered sedimentary rock – trenching, oversize • General demolition • Cutting casting gates
MOIL (P)		<ul style="list-style-type: none"> • Concrete structures – columns, etc. • Soft material
BLUNT (E)		<ul style="list-style-type: none"> • Concrete slab, bridge decking • Oversize • Slag removal
CORE (PC)		<ul style="list-style-type: none"> • Hard rock • General demolition

DIFFERENCE BETWEEN FX AND FY TOOLS

The crosscut (FX) tool cuts at right angle, or crosswise, to the stick and boom of the excavator.

TOOLS

CHANGING THE TOOL

REMOVAL

1. Remove the retaining ring by using pliers or screwdrivers, see Figures 1 and 2. It will easily come out if pulled at an angle as shown in Figure 2.
2. Screw an M12 bolt or cap screw into the retainer pin.
3. Pull out retainer pin. If the retainer pin is jammed, use a hammer and drift from the opposite side.

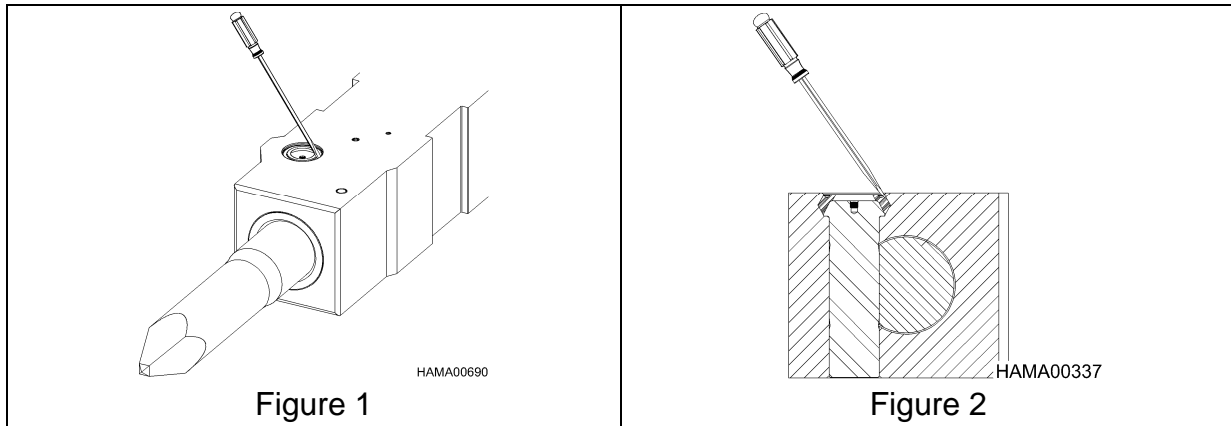

RE-INSTALLATION

1. Clean the retainer pin housing hole and retaining ring groove.
2. Coat the surface of the tool with grease, then install.
3. Apply grease to the retaining ring housing groove.
4. Coat the retaining pin with grease, then install.
5. Install the retaining ring in the following manner:
 - a. While deforming the retaining ring as shown in Figure 3, partially force it into the groove.
 - b. Using the handle of the pliers or screwdriver, press the rest of the ring into the groove, see Figure 4.

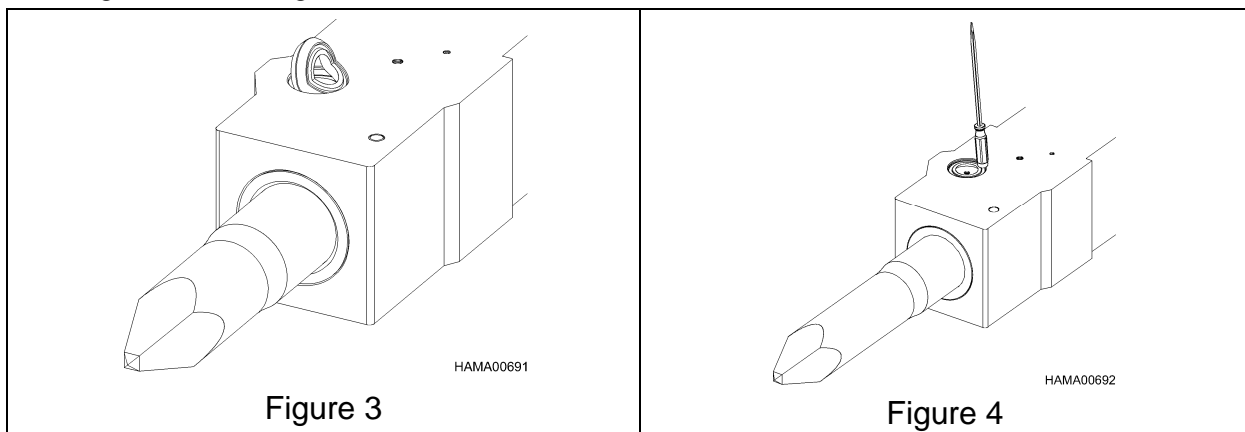

TOOLS

TOOL INSPECTION

1. Deformation may occur on the tool in the retaining pin contact area (15) or on thrust surface (31). If these areas are mushroomed, the tool may become difficult to remove from the tool holder. Dress with a grinder.

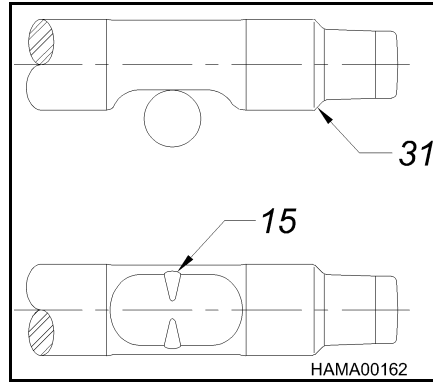

2. Excessive blank hammering may cause chipping (16) in the retaining pin contact area (15). If neglected, the chipping may reduce the life of the retaining pin. Dress area with a grinder (55).

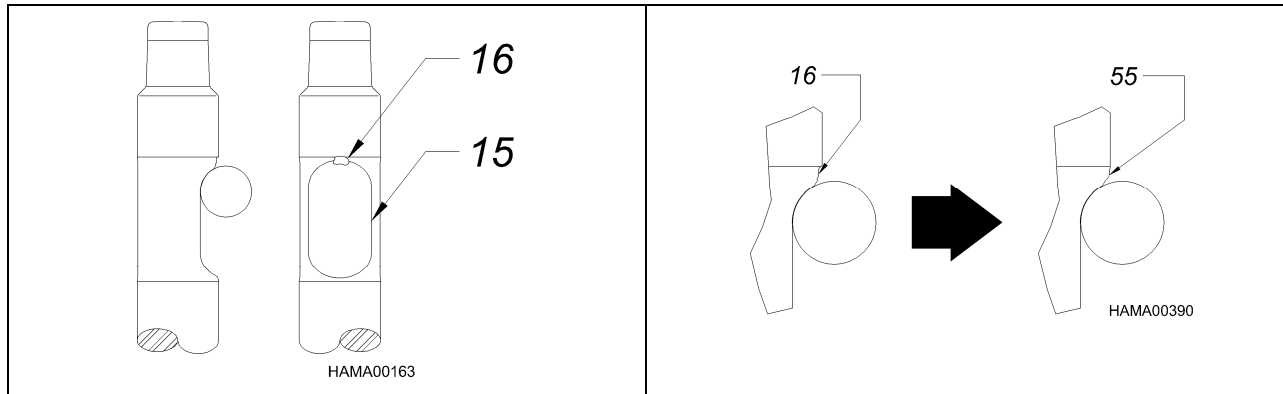

3. If chipping (16) is found at the top of the tool, replace the tool. If neglected, the piston impact surface will be damaged.

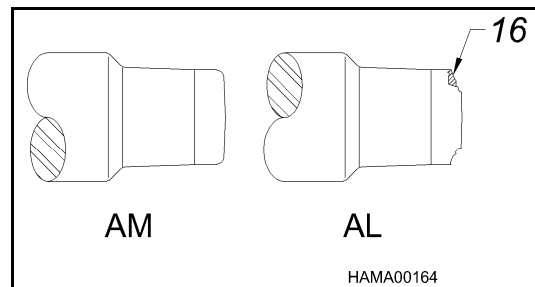

(AM) is normal
(AL) is chipped

TOOLS

MAXIMUM TOOL TO TOOL BUSHING CLEARANCE

Replace the tool bushing, and/or tool, when the tool to bushing gap reaches the maximum clearance.

Measure the tool to bushing gap with the hammer horizontal, as illustrated below. If the clearance is at or greater than the charted maximum clearance, consult the NPK Hydraulic Hammer Service Manual to determine which component requires replacement.

MODEL	MAXIMUM CLEARANCE inch (mm)
E208	3/8 (10)
E210A	3/8 (10)
E213	3/8 (10)
E216	1/2 (13)
E220	1/2 (13)
E225	1/2 (13)
E240A	5/8 (16)
E260A	5/8 (16)

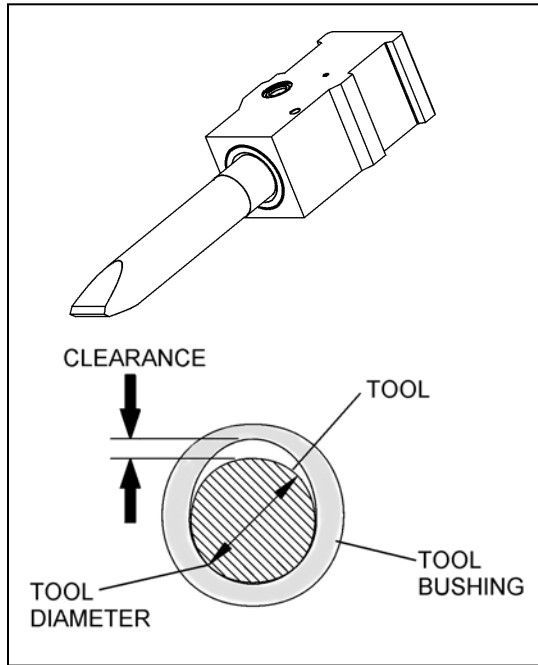

RETAINING PIN

The tool retaining pin (D) serves to keep the tool in the hammer when the hammer is raised off the ground for repositioning. Additionally, the retaining pin will become worn during normal use. Figure "A" shows the retaining pin when it is new. **Note:** the two guide grooves (AN). The guide groove areas and the area between the grooves are the areas where the wear will take place. If large, flat areas are found here, the pin must be replaced. *This would indicate that the hammer is not being greased frequently enough.*

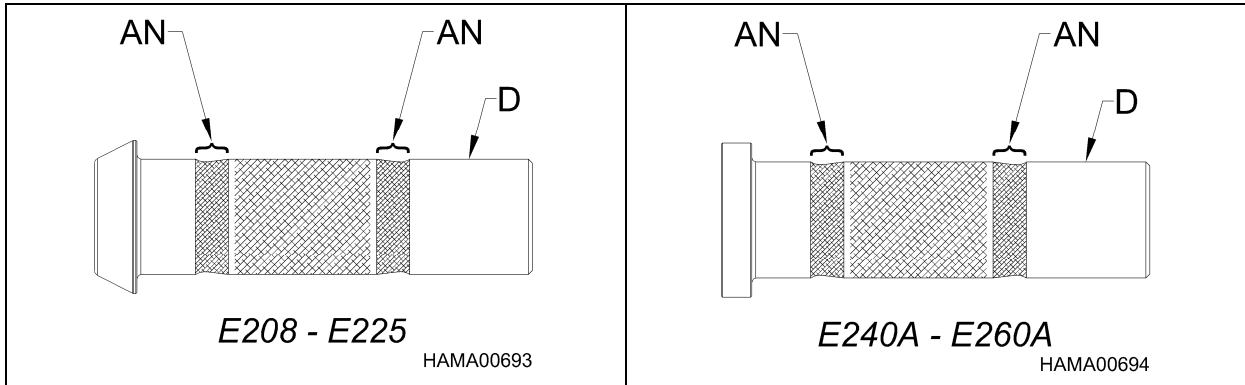

FIGURE "A"

Normal wear (20) will occur on the pin as shown in Figure "B". Grind this area on a bench grinder or with a disc grinder to remove any burrs. Reuse the pin.

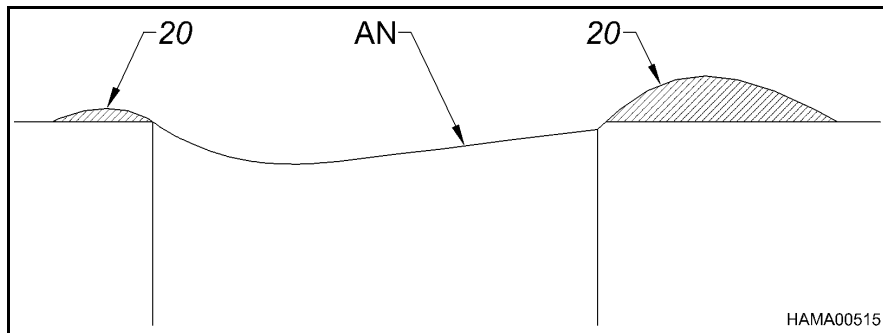
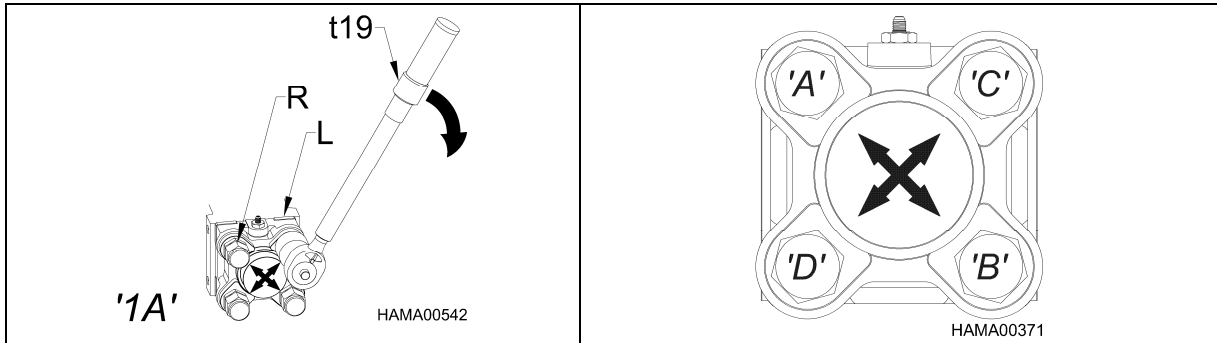

FIGURE "B"

TIE RODS

TIE ROD TORQUE

1. Tighten all top nuts (R), as shown in '1A', with a torque wrench (t19) to the recommended pre-torque specification shown in "CHART 1". (Tighten in a cross pattern only.) Make sure that no gaps are noted between the sections of the hammer assembly. (Note: It may take several passes at each top nut to achieve the above.)



2. Mark all top nuts (R) and the gas head (L) as shown in '1B'.

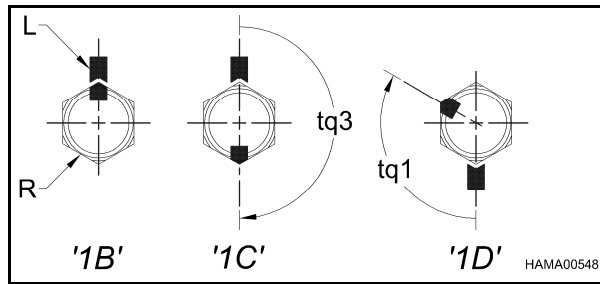

3. Locate the hammer model number in "CHART 1" to determine the total number of flats required to torque your hammer.

CHART 1

Hammer Model	Pre-torque Ft/lbs (Nm)	Total No. of Flats Using Std Anti-Seize	Total Angle (deg.) After Pre-torque	Socket Size Inch (mm)
E208	200 (270)	5	300	2-1/2" (63 mm)
E210A	200 (270)	3	180	2-9/16" (65 mm)
E213	200 (270)	4	240	2-3/4" (70 mm)
E216	200 (270)	5	300	3-1/8" (77 mm)
E220	200 (270)	5	300	3-1/8" (77 mm)
E225	200 (270)	5	300	3-3/8" (85 mm)

TIE RODS

TIE ROD TORQUE

4. Torque Procedure

E208, E216, E220, E225 hammers:

- a. Tighten each top nut (R) 3 flats (tq3) as shown in **'1C'**.
- b. Then tighten the top nuts 2 more flats (tq1) as shown in **'1D'**.
- c. The E208, E216, E220, E225 hammer torque is now complete.

E210A hammer:

- a. Tighten each top nut (R) 3 flats (tq3) as shown in **'1C'**.
- b. The E210A hammer torque is now complete.

E213 hammer:

- a. Tighten each top nut (R) 3 flats (tq3) as shown in **'1C'**.
- b. Then tighten the top nuts 1 more flat.
- c. The E213 hammer torque is now complete.

5. Apply silicone to the back side of the lock plates. Install the lock plates. If a lock plate does not drop into place, tighten the top nut until it does.
6. Install the snap rings.
7. Recharge the hammer with nitrogen gas. See the **"CHARGING THE HAMMER"** section of this manual.

HAMMER FASTENER TORQUE

If hammer or hammer bracket fasteners are found to be loose, use the following charts.

Medium strength thread adhesive should be used on all the valve assembly bolts and the gas charge valve. All other bolts should be lubed with anti-seize compound.

SOCKET HEAD CAP SCREWS (SHCS)

MODEL	VALVE CASE		VALVE TOP AND BOTTOM CAP		SWIVEL ADAPTOR	
	SHCS DIA	TORQUE ft/lb (Nm)	SHCS DIA	TORQUE ft/lb (Nm)	SHCS DIA	TORQUE ft/lb (Nm)
E208	M20	525 (710)	M20	525 (710)	M12	110 (150)
E210A	M24	900 (1220)	M22	710 (960)	M12	110 (150)
E213	M24	900 (1220)	M22	710 (960)	M12	110 (150)
E216	M24	900 (1220)	M22	710 (960)	M12	110 (150)
E220	M27	1300 (1750)	M24	900 (1220)	M14	175 (240)
E225	M27	1300 (1750)	M24	900 (1220)	M14	175 (240)
E240A	M27	1300 (1750)	M24	900 (1220)	M14	175 (240)
E260A	M27	1300 (1750)	M24	900 (1220)	M16	270 (365)

See *HAMMER DISASSEMBLY AND ASSEMBLY – TOOLS AND EQUIPMENT* section of Service Manual for NPK hex key wrench part numbers.

HEX HEAD BOLTS

MODEL	HAMMER BRACKET		RUBBER MOUNTS		TOP ADAPTOR BRACKET	
	BOLT DIA	TORQUE ft/lb (Nm)	BOLT DIA	TORQUE ft/lb (Nm)	BOLT DIA	TORQUE ft/lb (Nm)
E208	1-1/4"	1100 (1490)	M16	155 (210)	1"	550 (745)
E210A	1-1/4"	1100 (1490)	M16	155 (210)	1"	550 (745)
E213	1-1/4"	1100 (1490)	M16	155 (210)	1"	550 (745)
E216	1-1/2"	2000 (2710)	M20	300 (410)	1-1/4"	1100 (1490)
E220	1-1/2"	2000 (2710)	M20	300 (410)	1-1/4"	1100 (1490)
E225	1-1/2"	2000 (2710)	M20	300 (410)	1-1/4"	1100 (1490)
E240A	1-3/4"	2500 (3390)	M24	530 (720)	1-1/4"	1100 (1490)
E260A	2"	3000 (4065)	M24	530 (720)	1-1/4"	1100 (1490)

WARRANTY STATEMENTS

"Use Genuine NPK Parts" 6/08

NPK WARRANTY

BOOM MOUNTED HYDRAULIC HAMMER

APPLICATION FOR WARRANTY MUST BE MADE WITHIN 30 WORKING DAYS OF FAILURE / REPAIR.

BASE WARRANTY (6 months)
 NPK CONSTRUCTION EQUIPMENT, INC. ("NPK") warrants that new Boom Mounted Hydraulic Hammers sold by NPK will be free from defects in material or workmanship for a period of six (6) months, starting from the date of delivery to the first user. This warranty excludes all wear items, retaining pin, both upper and lower tool bushings, impact ring and bushing.

MAIN COMPONENT EXTENDED WARRANTY (1 year or 1,500 operating hours)
 The MAIN COMPONENT EXTENDED WARRANTY covers failure of the MAIN BODY, TOOL HOLDER, and GAS HEAD, resulting from defects in material or workmanship in those parts under normal use and service for the period starting with the expiration of the BASE WARRANTY and ends twelve (12) months or 1,500 operating hours, whichever occurs first, from the date of delivery of the hammer to the first user. NPK MAIN COMPONENT EXTENDED WARRANTY *does not* cover labor, travel expenses or the replacement or repair of any other part damaged due to MAIN BODY, TOOL HOLDER, or GAS HEAD failure or repair thereof.

THIS WARRANTY DOES NOT APPLY TO:

- DEMOLITION TOOLS and ACCESSORY TOOLS, HYDRAULIC and MOUNTING INSTALLATION KIT PARTS, HOSES, or REPLACEMENT PARTS, which are covered by other warranties.

NPK RESPONSIBILITY
 NPK will, at its option, repair or replace with a new or reconditioned part, any warranted part that fails by reason of defective material or workmanship, free of charge delivered at a place of business of an NPK Dealer. Note: Parts replaced under warranty become the property of NPK.

During the six (6) month BASE WARRANTY period, NPK will pay the cost of labor at 75% of the posted shop rate that is necessary to install any repaired or replacement part during normal working hours. Overtime rates and travel expenses will not be reimbursed.

USER RESPONSIBILITY

- *Photos must accompany all warranties submitted to NPK. These photos can be 35mm, polaroid, or digital.*
- The installer, user, operator, repairer, assumes responsibility to read, understand and comply with NPK's written INSTALLATION, OPERATOR and SERVICE INSTRUCTIONS.
- Returning Warranty Registration to NPK at the time of installation.
- All costs associated with transporting the NPK product, or equipment to which the NPK product is installed, to an authorized NPK Dealer or other authorized location. NPK is not responsible for any expense incurred in field repair.
- Supplying a hydraulic oil sample from the carrier machine upon request by NPK.

THESE WARRANTIES DO NOT COVER FAILURES RESULTING FROM:

- Misuse, abuse, alteration or improper installation.
- Maintenance, repair or storage which NPK judges improper.
- Not performing DAILY VISUAL INSPECTIONS as specified in the NPK MANUALS.
- Exceeding the tool and/or tool bushing wear limit.
- Underwater operation.
- Operation after discovery of defective or worn parts.
- Unreasonable delay in making a repair after being notified of a potential product problem.

THESE WARRANTIES SPECIFICALLY EXCLUDE:

- Installations not approved by NPK.
- Replacement due to normal wear.
- Repairs by other than an authorized NPK Dealer.
- Use of parts not sold by NPK. **THE USE OF "WILL FIT" PARTS WILL VOID ALL NPK WARRANTIES.**
- Labor charges that are deemed excessive by NPK.
- Parts shipping charges in excess of those which are usual and customary. (Air freight, unless pre-approved, will not be covered.)
- Duties, brokerage fees, and local taxes.

WARRANTY REPAIRS DO NOT EXTEND THE STANDARD WARRANTY PERIOD.

LIMITATIONS AND EXCLUSIONS
 Violation of any federal, provincial, state or local laws, ordinances, rules or regulations, or removal or alteration of product serial numbers void NPK's written product warranties. *Application for warranty must be made within 30 days of failure / repair.*

THIS PRODUCT MUST BE USED IN A SAFE AND LAWFUL MANNER IN COMPLIANCE WITH APPLICABLE OSHA REGULATIONS.

The written product warranties made by NPK set forth NPK's only obligations with respect to any claims of failure, defects or deficiencies in products sold by NPK. **NPK MAKES NO OTHER WARRANTIES OR REPRESENTATIONS WHATSOEVER, EXPRESS OR IMPLIED, OF THE QUALITY, PERFORMANCE, DURABILITY, MATERIALS, WORKMANSHIP, SUITABILITY, CONDITION, DESIGN OR UTILITY OF PRODUCTS SOLD BY NPK, INCLUDING, WITHOUT LIMITATION, IMPLIED WARRANTIES OF MERCHANTABILITY AND FITNESS, ALL SUCH OTHER WARRANTIES AND REPRESENTATIONS BEING HEREBY EXPRESSLY EXCLUDED. NPK SHALL NOT BE LIABLE FOR SPECIAL, INCIDENTAL OR CONSEQUENTIAL DAMAGES, INCLUDING, WITHOUT LIMITATION, COSTS, LOSSES OR LIABILITIES ON ACCOUNT OF DELAY OR DOWNTIME.**

DISCLAIMER REGARDING OTHER REPRESENTATIONS OR WARRANTIES
 No person is authorized to grant any other warranties or to assume any other liability on NPK's behalf unless made or assumed in writing by an officer of NPK. No person is authorized to grant any warranties or to assume any liabilities on the seller's behalf unless made or assumed in writing by the seller.

Internet: www.npkce.com
 As used in this warranty the term NPK means NPK CONSTRUCTION EQUIPMENT, INC., WALTON HILLS, OHIO, U.S.A.

WARRANTY STATEMENTS

"Use Genuine NPK Parts" 6/08

NPK WARRANTY REPLACEMENT PARTS

APPLICATION FOR WARRANTY MUST BE MADE WITHIN 30 WORKING DAYS OF FAILURE / REPAIR.

REPLACEMENT PARTS WARRANTY (90 days)

NPK CONSTRUCTION EQUIPMENT, INC. ("NPK") warrants that new Replacement Parts sold by NPK will be free from defects in material or workmanship for a period of ninety (90) days, starting from the date of installation. NPK Replacement Parts Warranty **does not** cover labor or travel expenses. Note: Unexpired New Product Warranty has priority over Replacement Parts Warranty.

THIS WARRANTY DOES NOT APPLY TO:

- Wear items such as upper and lower tool bushings, impact ring, retaining bars and pins.
- Tools (covered under separate Tool Warranty).

NPK RESPONSIBILITY

NPK will, at its option, repair or replace with a new or reconditioned part, any warranted part that fails by reason of defective material or workmanship, free of charge delivered at a place of business of an NPK Dealer. Note: Parts replaced under warranty become the property of NPK.

USER RESPONSIBILITY

- **Photos must accompany all warranties submitted to NPK. These photos can be 35mm, polaroid, or digital.**
- The installer, user, operator, repairer, assumes responsibility to read, understand and comply with NPK's written INSTALLATION, OPERATOR and SERVICE INSTRUCTIONS.
- All labor costs.
- Any expense incurred by field repair.
- Supplying a hydraulic oil sample from the carrier machine upon request by NPK.

THESE WARRANTIES DO NOT COVER FAILURES RESULTING FROM:

- Installation, alteration, operation, maintenance, repair or storage which NPK judges improper.
- Not performing DAILY VISUAL INSPECTIONS and/or RETIGHTENING of fasteners after initial 20 operating hours after repair.
- Exceeding the tool and/or tool bushing wear limit.
- Underwater operation.
- Operation after discovery of defective or worn parts.
- Unreasonable delay in making a repair after being notified of a potential product problem.

THESE WARRANTIES SPECIFICALLY EXCLUDE:

- Installations not approved by NPK.
- Replacement due to normal wear.
- Use of parts not sold by NPK. **THE USE OF "WILL FIT" PARTS WILL VOID ALL NPK WARRANTIES.**
- Parts shipping charges in excess of those which are usual and customary. (Air freight, unless pre-approved, will not be covered.)
- Duties, brokerage fees, and local taxes.

WARRANTY REPAIRS DO NOT EXTEND THE STANDARD WARRANTY PERIOD.

Internet: www.npkce.com

As used in this warranty the term NPK means NPK CONSTRUCTION EQUIPMENT, INC., WALTON HILLS, OHIO, U.S.A.

LIMITATIONS AND EXCLUSIONS

Violation of any federal, provincial, state or local laws, ordinances, rules or regulations, or removal or alteration of product serial numbers void NPK's written product warranties. **Application for warranty must be made within 30 days of failure / repair.**

THIS PRODUCT MUST BE USED IN A SAFE AND LAWFUL MANNER IN COMPLIANCE WITH APPLICABLE OSHA REGULATIONS.

The written product warranties made by NPK set forth NPK's only obligations with respect to any claims of failure, defects or deficiencies in products sold by NPK. **NPK MAKES NO OTHER WARRANTIES OR REPRESENTATIONS WHATSOEVER, EXPRESS OR IMPLIED, OF THE QUALITY, PERFORMANCE, DURABILITY, MATERIALS, WORKMANSHIP, SUITABILITY, CONDITION, DESIGN OR UTILITY OF PRODUCTS SOLD BY NPK, INCLUDING, WITHOUT LIMITATION, IMPLIED WARRANTIES OF MERCHANTABILITY AND FITNESS, ALL SUCH OTHER WARRANTIES AND REPRESENTATIONS BEING HEREBY EXPRESSLY EXCLUDED. NPK SHALL NOT BE LIABLE FOR SPECIAL, INCIDENTAL OR CONSEQUENTIAL DAMAGES, INCLUDING, WITHOUT LIMITATION, COSTS, LOSSES OR LIABILITIES ON ACCOUNT OF DELAY OR DOWNTIME.**

DISCLAIMER REGARDING OTHER REPRESENTATIONS OR WARRANTIES

No person is authorized to grant any other warranties or to assume any other liability on NPK's behalf unless made or assumed in writing by an officer of NPK. No person is authorized to grant any warranties or to assume any liabilities on the seller's behalf unless made or assumed in writing by the seller.

WARRANTY STATEMENTS

"Use Genuine NPK Parts"

6/08

NPK WARRANTY AUTOLUBE SYSTEM

APPLICATION FOR WARRANTY MUST BE MADE WITHIN 30 WORKING DAYS OF FAILURE / REPAIR.

BASE WARRANTY (6 months)

NPK CONSTRUCTION EQUIPMENT, INC. ("NPK") warrants that new AUTOLUBE assemblies sold by NPK will be free from defects in material or workmanship for a period of six (6) months, starting from the date of delivery to the first user.

MAIN COMPONENT EXTENDED WARRANTY (12 months)

The MAIN COMPONENT EXTENDED WARRANTY covers failure of the MOTOR and DRIVE ASSEMBLY, resulting from defects in material or workmanship in those parts under normal use and service for the period starting with the expiration of the BASE WARRANTY and ends twelve (12) months from the date of delivery to the first user. NPK MAIN COMPONENT EXTENDED WARRANTY **does not** cover labor, travel expenses or the replacement or repair of any other part damaged due to MOTOR or DRIVE ASSEMBLY failure or repair thereof.

THIS WARRANTY DOES NOT APPLY TO:

- REPLACEMENT PARTS, which are covered by other NPK warranties, or hose assemblies and fittings which are not supplied by NPK.

NPK RESPONSIBILITY

NPK will, at its option, repair or replace with a new or reconditioned part, any warranted part that fails by reason of defective material or workmanship, free of charge delivered at a place of business of an NPK Dealer. Note: Parts replaced under warranty become the property of NPK.

During the six (6) month BASE WARRANTY period, NPK will pay the cost of labor at 75% of the posted shop rate that is necessary to install any repaired or replacement warranted part during normal working hours. Overtime rates and travel expenses will not be reimbursed.

USER RESPONSIBILITY

- **Photos must accompany all warranties submitted to NPK. These photos can be 35mm, polaroid, or digital.**
- The installer, user, operator, repairer, assumes responsibility to read, understand and comply with NPK's written INSTRUCTION MANUAL.
- Returning Warranty Registration to NPK at the time of installation.
- All costs associated with shipping the AUTOLUBE unit to an authorized NPK Dealer or other authorized location. NPK is not responsible for any expense incurred in field repair.

THESE WARRANTIES DO NOT COVER FAILURES RESULTING FROM:

- Installation, alteration, operation, maintenance, repair or storage which NPK judges improper.
- Operation after discovery of defective or worn parts.
- Unreasonable delay in making a repair after being notified of a potential product problem.
- Use of grease containing abrasive compounds.
- Contamination.

THESE WARRANTIES SPECIFICALLY EXCLUDE:

- Installations not approved by NPK.
- Replacement due to normal wear.
- Repairs by other than an authorized NPK Dealer.
- Use of parts not sold by NPK. **THE USE OF "WILL FIT" PARTS WILL VOID ALL NPK WARRANTIES.**
- Labor charges that are deemed excessive by NPK.
- Parts shipping charges in excess of those which are usual and customary. (Air freight, unless pre-approved, will not be covered.)
- Duties, brokerage fees, and local taxes.

WARRANTY REPAIRS DO NOT EXTEND THE STANDARD WARRANTY PERIOD.

LIMITATIONS AND EXCLUSIONS

Violation of any federal, provincial, state or local laws, ordinances, rules or regulations, or removal or alteration of product serial numbers void NPK's written product warranties. **Application for warranty must be made within 30 days of failure / repair.**

THIS PRODUCT MUST BE USED IN A SAFE AND LAWFUL MANNER IN COMPLIANCE WITH APPLICABLE OSHA REGULATIONS.

The written product warranties made by NPK set forth NPK's only obligations with respect to any claims of failure, defects or deficiencies in products sold by NPK. **NPK MAKES NO OTHER WARRANTIES OR REPRESENTATIONS WHATSOEVER, EXPRESS OR IMPLIED, OF THE QUALITY, PERFORMANCE, DURABILITY, MATERIALS, WORKMANSHIP, SUITABILITY, CONDITION, DESIGN OR UTILITY OF PRODUCTS SOLD BY NPK, INCLUDING, WITHOUT LIMITATION, IMPLIED WARRANTIES OF MERCHANTABILITY AND FITNESS, ALL SUCH OTHER WARRANTIES AND REPRESENTATIONS BEING HEREBY EXPRESSLY EXCLUDED. NPK SHALL NOT BE LIABLE FOR SPECIAL, INCIDENTAL OR CONSEQUENTIAL DAMAGES, INCLUDING, WITHOUT LIMITATION, COSTS, LOSSES OR LIABILITIES ON ACCOUNT OF DELAY OR DOWNTIME.**

DISCLAIMER REGARDING OTHER REPRESENTATIONS OR WARRANTIES

No person is authorized to grant any other warranties or to assume any other liability on NPK's behalf unless made or assumed in writing by an officer of NPK. No person is authorized to grant any warranties or to assume any liabilities on the seller's behalf unless made or assumed in writing by the seller.

Internet: www.npkce.com

As used in this warranty the term NPK means NPK CONSTRUCTION EQUIPMENT, INC., WALTON HILLS, OHIO, U.S.A.

WARRANTY STATEMENTS

APPLICATION FOR WARRANTY MUST BE
MADE WITHIN 30 WORKING DAYS OF
FAILURE / REPAIR.



WARRANTY

"Use Genuine NPK Parts" 6/08

STANDARD DEMOLITION AND ACCESSORY TOOLS

STANDARD DEMOLITION and ACCESSORY TOOLS WARRANTY (30 days)

NPK CONSTRUCTION EQUIPMENT, INC. ("NPK") warrants that new Standard Demolition Tools, and other Standard Accessory Tools sold by NPK will be free from defects in material or workmanship for a period of thirty (30) days, starting from the date of installation. NPK reserves the full right to determine if, and to what extent, warranty adjustments may be made for breakage of the demolition or other accessory tools. **NPK Tool Warranty does not cover labor or travel expenses.**

THIS WARRANTY DOES NOT APPLY TO:

- Custom or special application tools which are excluded from warranty.

NPK RESPONSIBILITY

NPK will, at its option, replace with a new or reconditioned tool, any warranted tool that fails by reason of defective material or workmanship, free of charge delivered at a place of business of an NPK Dealer. Tool breakage is specifically covered ONLY for straight across breakage as shown at locations A1.

For warranted tool failures, a prorated credit, up to 80% maximum, will be issued for tools with tip wear greater than 50 mm on chisel andmoil points, or 30 mm on blunt end tools. Note: Parts replaced under warranty become the property of NPK.

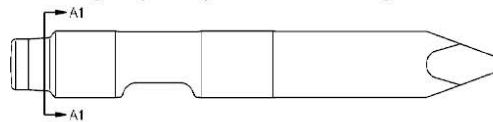

USER RESPONSIBILITY

- Photos and all numbers from retaining pin slot must accompany all warranties submitted to NPK. These photos can be 35 mm, polaroid, or digital.
- The installer, user, operator, repairer, assumes responsibility to read, understand and comply with NPK's written INSTALLATION, OPERATOR and SERVICE INSTRUCTIONS.
- All labor costs.
- Any expense incurred by field repair.
- Tool failures as shown at locations B (see NPK Operators Manual for correct operating procedures):

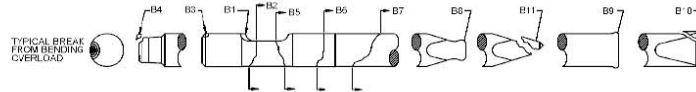

CAUSE OF FAILURE

B1 and B2 - repeated blank hammering.
B2 - bending overload due to excessive wear of the tool bushings.
B3 and B4 - corner loading due to excessive wear of the tool bushings.

B5, B6 and B7 - bending overload from excessive prying or slant hammering.
B8 and B9 - deformation from overheating by hammering in the same position for more than 30 seconds.
B10 and B11 - chipped, due to wrong application, or overheating by hammering in same position for over 30 seconds.

THESE WARRANTIES DO NOT COVER FAILURES RESULTING FROM:

- Installation, alteration, operation, maintenance, repair or storage which NPK judges improper.
- Inadequate lubrication.
- Exceeding the tool and/or tool bushing wear limit.
- Unreasonable delay in making a repair after being notified of a potential product problem.

THESE WARRANTIES SPECIFICALLY EXCLUDE:

- Any tool which is altered, welded, hardfaced or resharpened.
- Replacement due to tip or shank wear.
- Installations not approved by NPK.
- Use of parts not sold by NPK. **THE USE OF "WILL FIT" PARTS WILL VOID ALL NPK WARRANTIES.**
- Parts shipping charges in excess of those which are usual and customary. (Air freight, unless pre-approved, will not be covered.)
- Duties, brokerage fees, and local taxes.

WARRANTY REPAIRS DO NOT EXTEND THE STANDARD WARRANTY PERIOD.

Internet: www.npkce.com

As used in this warranty the term NPK means NPK CONSTRUCTION EQUIPMENT, INC., WALTON HILLS, OHIO, U.S.A.

LIMITATIONS AND EXCLUSIONS

Violation of any federal, provincial, state or local laws, ordinances, rules or regulations, or removal or alteration of product serial numbers void NPK's written product warranties.

Application for warranty must be made within 30 days of failure / repair.

THIS PRODUCT MUST BE USED IN A SAFE AND LAWFUL MANNER IN COMPLIANCE WITH APPLICABLE OSHA REGULATIONS.

The written product warranties made by NPK set forth NPK's only obligations with respect to any claims of failure, defects or deficiencies in products sold by NPK. **NPK MAKES NO OTHER WARRANTIES OR REPRESENTATIONS WHATSOEVER, EXPRESS OR IMPLIED, OF THE QUALITY, PERFORMANCE, DURABILITY, MATERIALS, WORKMANSHIP, SUITABILITY, CONDITION, DESIGN OR UTILITY OF PRODUCTS SOLD BY NPK, INCLUDING WITHOUT LIMITATION, IMPLIED WARRANTIES OF MERCHANTABILITY AND FITNESS. ALL SUCH OTHER WARRANTIES AND REPRESENTATIONS BEING HEREBY EXPRESSLY EXCLUDED. NPK SHALL NOT BE LIABLE FOR SPECIAL, INCIDENTAL OR CONSEQUENTIAL DAMAGES, INCLUDING WITHOUT LIMITATION, COSTS, LOSSES OR LIABILITIES ON ACCOUNT OF DELAY OR DOWNTIME.**

DISCLAIMER REGARDING OTHER REPRESENTATIONS OR WARRANTIES

No person is authorized to grant any other warranties or to assume any other liability on NPK's behalf unless made or assumed in writing by an officer of NPK. No person is authorized to grant any warranties or to assume any liabilities on the seller's behalf unless made or assumed in writing by the seller.

STORAGE OF HYDRAULIC HAMMER

For short term storage between jobs, place the hammer horizontal on wood blocks. Be sure the tool is liberally greased and the hydraulic hoses are capped. Cover with a waterproof tarp.

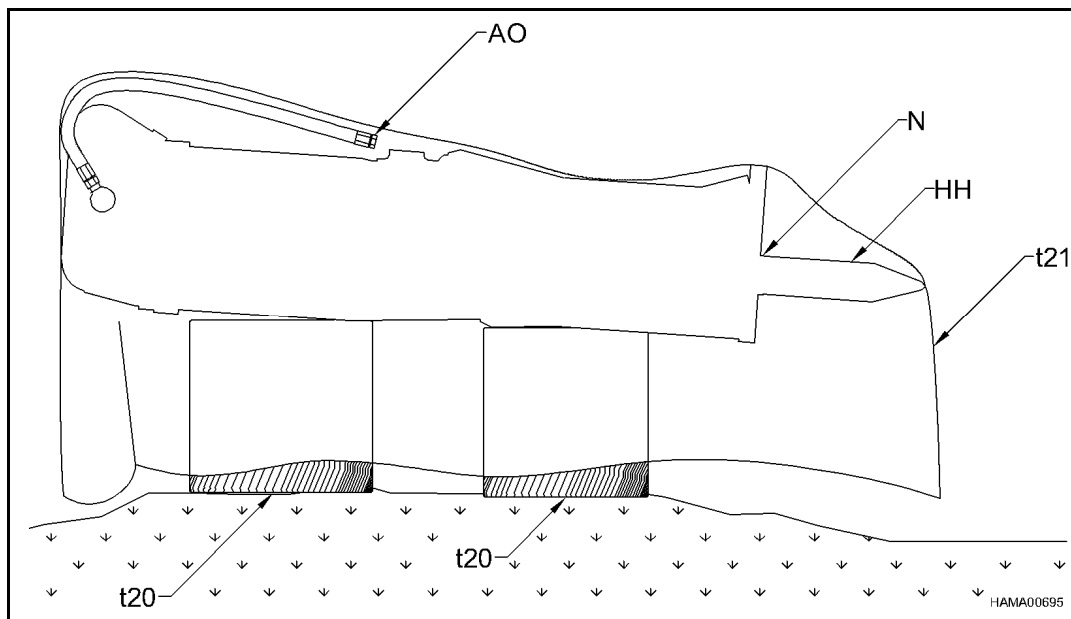

If the NPK HYDRAULIC HAMMER is not to be used for a long period of time (months), the following storage procedure is recommended:

1. Discharge the gas pressure.
2. Remove the Tool and push the Piston all the way in.
3. Grease the exposed end of the Piston (N).
4. Grease and reinstall the Tool (HH).
5. Plug the hydraulic hoses (AO).
6. Cover with a waterproof tarp (t21).
7. Set the hammer on wood blocks (t20).

NOTES AND RECORDS

NPK HYDRAULIC HAMMER MODEL NUMBER _____

SERIAL NUMBER _____

NPK INSTALLATION KIT NUMBER _____

CARRIER MANUFACTURER	
MODEL NUMBER	
SERIES	
SERIAL NUMBER	

DATE OF INSTALLATION _____

DATE OF 20 HOUR INSPECTION _____ WARRANTY REGISTRATION SENT

