



# SHEAR

# INSTRUCTION MANUAL

## MODELS:

**K3JFR, K3JR, K3JREH**  
**K4JFR, K4JR, K4JREH**  
**K7JFR, K7JR, K7JREH**

*“Use Genuine NPK Parts”*

**NPK** *...attachments;  
designed, built  
and backed by NPK.*

7550 Independence Drive  
Walton Hills, OH 44146-5541  
Phone (440) 232-7900  
Fax (440) 232-6294

# CONTENTS

---

SAFETY .....	4
OPERATION .....	5
MAINTENANCE .....	6
INTRODUCTION.....	8
CARRIER COMPATIBILITY.....	8
SPECIFICATIONS .....	9
K3J SHEAR .....	9
K4J SHEAR .....	10
K7J SHEAR.....	11
ROTATION UNIT: K3JR, K4JR, K7JR.....	12
MECHANICAL ROTATION STOPPER.....	14
INSPECTION AND REPLACEMENT OF STOPPER .....	14
CUTTING FORCE.....	15
JAW CUTTING CAPACITY.....	16
SERIAL NUMBER LOCATION .....	17
SHEAR BOOSTER CYLINDER .....	18
I INTRODUCTION.....	18
II STRUCTURE OF THE BOOSTER CYLINDER.....	19
III OPERATING PRINCIPLE .....	20
HYDRAULIC INSTALLATION.....	28
FLOW DIRECTION .....	28
SHUT-OFF VALVES .....	28
HYDRAULIC QUICK DISCONNECTS.....	29
PREVENTION OF CONTAMINATION.....	31
MOUNTING INSTALLATION.....	32
MOUNTING INSTALLATION KIT .....	32
MOUNTING TO THE CARRIER .....	32
REMOVAL FROM THE CARRIER.....	33
STORAGE OF THE SHEAR.....	33
HOSE INSTALLATION .....	34
HOSE INSTALLATION TIPS .....	34
OPERATING INSTRUCTIONS.....	36
OPERATING TECHNIQUES AND PRECAUTIONS.....	37
GENERAL MAINTENANCE.....	39
DAILY INSPECTION AND MAINTENANCE .....	39
LUBRICATION POINTS – K3JR, K4JR, K7JR .....	41
COMPONENT DESCRIPTION – K3JR, K4JR, K7JR.....	42
CUTTER BLADE MAINTENANCE.....	43
BLADE-TO-BLADE CLEARANCE .....	43
JAW BLADE SET UP PROCEDURE.....	44
BLADE INSTALLATION .....	45
MOVEABLE JAW BLADE INSTALLATION .....	45
MAIN FRAME BLADE INSTALLATION .....	47
PIVOT GROUP ADJUSTMENT.....	49
PREPARATION.....	49
PARTS DESCRIPTION.....	50
PRINCIPAL OF JAW ADJUSTMENT .....	51
PROPER CLEARANCES.....	51
ADJUSTMENT PROCEDURE .....	53
JAW INSPECTION AND MAINTENANCE.....	59
WEEKLY INSPECTION .....	59
HARDFACING.....	59
JAW REBUILD PROCEDURE .....	59
FRAME MAINTENANCE – REPAIR OF MAIN FRAME .....	62
ROUTINE WELD REPAIR .....	62
INSPECTION AND MAINTENANCE .....	64
BOOSTER/CYLINDER DISASSEMBLY AND INSPECTION .....	64
CYLINDER COMPONENT DISASSEMBLY .....	64

# CONTENTS

---

BOOSTER COMPONENT DISASSEMBLY .....	67
INSPECTING AND CLEANING BOOSTER/CYLINDER COMPONENTS .....	72
BOOSTER COMPONENT ASSEMBLY .....	73
CYLINDER COMPONENT ASSEMBLY .....	78
INSPECTION AND MAINTENANCE .....	82
ROTATOR HEAD.....	82
LEAKAGE OF THE SEALS.....	82
TESTING THE ROTATOR HEAD SEALS FOR INTERNAL LEAKAGE .....	82
PROCEDURE.....	83
HOSE TORQUE SPECIFICATIONS .....	84
JIC ENDS .....	84
ORFS ENDS .....	84
TROUBLESHOOTING .....	85
DETERMINE THE TYPE OF PROBLEM.....	85
DETERMINE THE CAUSE OF THE PROBLEM.....	85
LOSS OF POWER .....	85
TROUBLESHOOTING GUIDE FOR LOW POWER .....	86
RELIEF VALVE CHECKS .....	86
MEASURING OPERATING PRESSURES .....	88
RELIEF VALVE CHECKING AND SETTING PROCEDURE.....	88
PRESSURE INTENSIFIER RELIEF VALVE ACTUATION.....	91
SHEAR RELIEF VALVE AND CARRIER RELIEF VALVE SETTINGS .....	92
RELIEF VALVE LOCATION.....	92
INTENSIFIER CHECKS ( <i>unit does not click</i> ).....	93
INTENSIFIER CHECKS ( <i>unit clicks – does not slow down</i> ).....	94
PRESSURE INTENSIFIER OPERATION.....	94
PRESSURE INTENSIFIER (BOOSTER).....	94
RAPID CONTINUOUS CLICKING IS HEARD AND THE MATERIAL IS NOT BEING SHEARED AS EXPECTED .....	95
CHECKING BOOSTED PRESSURE .....	95
SLOW CYCLE SPEED.....	96
TEST PROCEDURE .....	96
CHECKING THE HYDRAULIC FLOW AT RATED PRESSURE .....	98
JAW DRIFT .....	99
TO DETERMINE IF THE JAW DRIFT IS WITH THE SHEAR OR THE CARRIER .....	99
ROTATION .....	100
MEASURING ROTATION PRESSURES.....	101
IF THE UNIT WILL NOT ROTATE .....	101
UNIT WILL NOT HOLD POSITION.....	101
KEYWORDS FOR COMMON K-SERIES SHEAR COMPONENTS .....	102
KEYWORDS FOR COMMON K-SERIES BOOSTER/CYLINDER COMPONENTS .....	103
FASTENER TORQUE SPECIFICATIONS .....	104
WARRANTY STATEMENTS .....	107
NOTES .....	109
SERVICE RECORD.....	109

# SAFETY

---



Safety notices in NPK Instruction Manuals follow ISO and ANSI standards for safety warnings:



DANGER (red) notices indicate an imminently hazardous situation which, if not avoided, **will result in death or serious injury**.



WARNING (orange) notices indicate a potentially hazardous situation which, if not avoided, **could result in death or serious injury**.



CAUTION (yellow) notices indicate a potentially hazardous situation, which, if not avoided, **may result in minor or moderate injury**.



ATTENTION (blue) notices in NPK Instruction Manuals are an NPK standard to alert the reader to situations which, if not avoided, **could result in equipment damage**.

---

**WARNING – FALLING OR FLYING DEBRIS** decals are included with each NPK HYDRAULIC SHEAR. The decal must be installed in the cab, visible to the operator.

**WARNING – STAY CLEAR** decals are installed on all NPK HYDRAULIC SHEARS. Keep them clean and visible. NPK will provide decals free of charge as needed. It is important to NPK that every precaution is taken to ensure the safety of the operators and surrounding personnel.



# SAFETY

## OPERATION

### **WARNING**

1. Operator personnel must read and understand the **NPK INSTRUCTION MANUAL** to prevent serious or fatal injury.
2. **FLYING OR FALLING DEBRIS CAN CAUSE SERIOUS OR FATAL INJURY.** Keep personnel and bystanders clear of the HYDRAULIC SHEAR while in operation.
3. Do not operate HYDRAULIC SHEAR without an impact resistant shield between the HYDRAULIC SHEAR and operator. Operate with extreme caution near walls or columns that may collapse and near concrete debris that may fall.
4. Operate the HYDRAULIC SHEAR from the operator's seat only.
5. Use two people whenever operator visibility is limited, one to operate the HYDRAULIC SHEAR, the other to guide operations.
6. **Do not** leave a load suspended in air.
7. **Do not** pass a load over people, vehicles, etc.
8. **Do not** operate the HYDRAULIC SHEAR within reach of power lines.
9. **Do not** climb, sit, or ride on the HYDRAULIC SHEAR.



Warning Decal for Cab Installation

### **CAUTION**

10. Match the HYDRAULIC SHEAR size to excavator according to NPK recommendations, see page 8. The excavator must be stable during HYDRAULIC SHEAR operation and during transport.
11. **Do not** operate without inspection (access) covers in place.
12. Be especially cautious around hydraulic lines. Hydraulic oil can be extremely **HOT!** **Avoid skin contact with hydraulic oil. It can cause severe burns!**
13. **Protect hands and body from hydraulic fluids under pressure.** Escaping high pressure fluid can penetrate the skin, causing serious injury. Avoid the hazard by relieving pressure before disconnecting any lines. Search for leaks with a piece of cardboard, or other object. **If an accident occurs, see a doctor immediately! Hydraulic fluid injected into the skin must be surgically removed immediately or gangrene may result!**
14. The pressure generated by the power intensifier on the HYDRAULIC SHEAR exceeds 10,000 psi (690 bar), which is higher than commonly encountered on hydraulic equipment. To avoid bodily harm and/or injury when conducting inspection checks, use gauges, hoses and fittings rated at 15,000 psi (1035 bar). For parts replacement, use only genuine NPK replacement parts. Contact the NPK Service Department at 440-232-7900.
15. When removing or installing mounting pins, beware of flying metal chips.

# SAFETY

---

## MAINTENANCE



1. Use only NPK supplied replacement parts. NPK specifically disclaims any responsibility for bodily injury or HYDRAULIC SHEAR damage that results from the use of parts not sold or approved by NPK.
2. Use extreme caution in handling. A fully assembled K7JR HYDRAULIC SHEAR can weigh up to 1,820 lbs (825 kg). Sub-assemblies' range in weight up to hundreds of pounds. To avoid bodily harm, use lifting and securing mechanisms of adequate capacity to support loads. Seek the aid of an assistant as much as possible, and always when handling heavier sub-assemblies.
3. Wear safety glasses and protective clothing when working on the HYDRAULIC SHEAR. Wear thermal-protective gloves when handling heated parts.
4. Prevent exposure to hazardous fumes. Remove all paint, grease, and oil before heating, cutting or welding on the HYDRAULIC SHEAR.
5. Be especially cautious around hydraulic lines. Hydraulic oil can be extremely **HOT!** ***Avoid skin contact with hydraulic oil! It can cause severe burns!***
6. **Protect hands and body from hydraulic fluids under pressure.** Escaping fluid under pressure can penetrate the skin, causing serious injury. Avoid the hazard by relieving pressure before disconnecting any lines. Search for leaks with a piece of cardboard, or other object. ***If an accident occurs, see a doctor immediately! Hydraulic fluid injected into the skin must be surgically removed within a few hours or gangrene may result.***
7. The pressure generated by the power intensifier on the HYDRAULIC SHEAR exceeds **10,000 psi (690 bar)**, which is higher than commonly encountered on hydraulic equipment. To avoid bodily harm and/or injury when conducting inspection checks, use gauges, hoses and fittings rated at 15,000 psi (1035 bar). For parts replacement, use only genuine NPK replacement parts. Contact the NPK Service Department at 440-232-7900.
8. When removing or installing mounting pins, beware of flying metal chips.

# SAFETY

---

## MAINTENANCE

### STANDARD PRACTICES

#### ATTENTION

Maintenance of and repairs to the HYDRAULIC SHEAR should be performed by an experienced service technician, thoroughly familiar with all standard practices and procedures, and most importantly, all safety precautions. The following is a review of common standard practices to be followed when working with hydraulic equipment and is not meant to be all-inclusive. Rather, this review is presented as a reminder as to some of the unique characteristics of hydraulic equipment.

- The prevention of foreign contaminant damage is critical when working with hydraulic equipment. Protect exposed holes and parts to guard against entry of contaminants. Install metal or plastic plugs/caps where applicable to prevent entry of debris into the hydraulic system.
- Mark the location and position of mating parts as an aid to re-assembly. Mark corresponding parts uniquely to reflect their relationship, including proper location, position, orientation, and/or alignment.

#### DO:

- During assembly, observe all markings made during disassembly, and all corresponding features of mating parts to ensure proper location, position, orientation, and alignment.
- During disassembly of a sub-assembly, place removed components on a clean, dry surface, in proper relative position as an aid in re-assembly.
- Always inspect threaded areas on components. Repair or replace as required. Never apply uncured thread adhesive to a fastener that has cured adhesive on it. Clean the fastener and the threaded bore. A tap and die may be helpful for this task. Be sure to remove loose debris from the threaded bore.
- Use care to avoid scratches, nicks, dents, or other damage to machined surfaces of mating components.
- When securing a component, always tighten cap screws gradually in an opposing pattern, applying the specified torque.
- Grease can be used to temporarily hold a part in place while the abutting part is placed into position.
- Always use common sense and exercise standard safety precautions when working with all tools and equipment required to maintain, repair, or troubleshoot the HYDRAULIC SHEAR.

# INTRODUCTION

---

NPK prides itself on the design and manufacture of high-quality products. This tradition of quality workmanship and materials continues in our K3JR/K4JR/K7JR HYDRAULIC SHEARS. Many years of productive service can be realized with proper operation and care of the HYDRAULIC SHEAR.

The purpose of this manual is to provide you with the information and instructions required to properly operate and maintain the HYDRAULIC SHEAR. This will result in maximum HYDRAULIC SHEAR reliability and productivity.

**Read this manual thoroughly** before attempting to operate, remove, disassemble, repair or troubleshoot the HYDRAULIC SHEAR or any of its components.

**Follow all the safety precautions** contained in this manual. **Failure to do so, can result in death, personal injury, injury to others, and property damage!**

## CARRIER COMPATIBILITY

---

These carrier weight ranges are intended as a guideline only. Other factors, such as stick length, counterweights, undercarriage, etc., must be taken into consideration.



Mounting a HYDRAULIC SHEAR that is too heavy for the carrier can be dangerous and damage the machine. Verify carrier stability with the HYDRAULIC SHEAR before transport or operation.

Mounting a HYDRAULIC SHEAR that is too small for the carrier can damage the HYDRAULIC SHEAR and void Warranties. Please consult NPK Engineering for specific detailed information.

MODEL	RECOMMENDED CARRIER CLASS 3rd member mounting	
	lbs.	<i>Metric tons</i>
<b>K3JFR</b>	5,500 - 9,000	(2.5 - 4)
<b>K3JR</b>	8,000 - 15,500	(3.5 - 7)
<b>K3JREH</b>	9,000 - 15,500	(4 - 7)
<b>K4JFR</b>	8,000 - 12,000	(3.5 - 5.5)
<b>K4JR</b>	9,000 - 20,000	(4 - 9)
<b>K4JREH</b>	10,000 - 20,000	(4.5 - 9)
<b>K7JFR</b>	13,000 - 20,000	(6 - 9)
<b>K7JR</b>	13,000 - 31,000	(6 - 14)
<b>K7JREH</b>	13,000 - 31,000	(6 - 14)

# SPECIFICATIONS

## K3J SHEAR

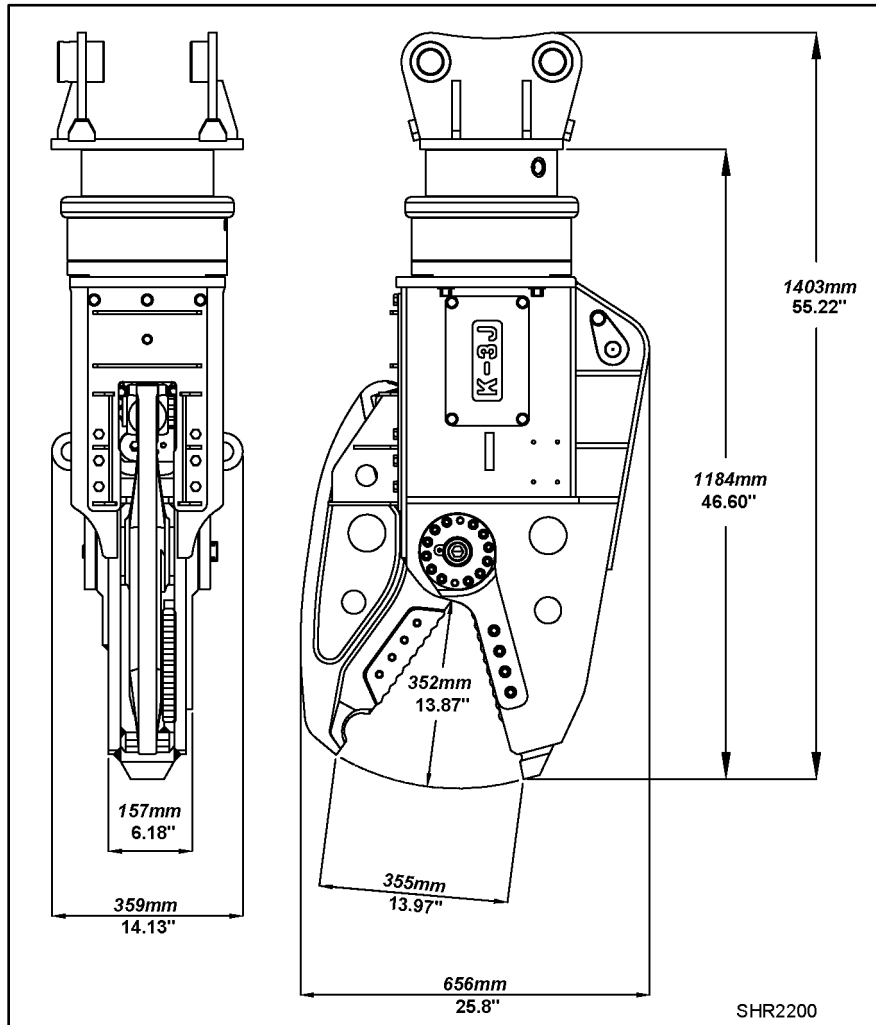

MODELS	OIL FLOW		OPERATING PRESSURE		CIRCUIT RELIEF minimum		MAXIMUM CUTTING FORCE	
	gpm	(lpm)	psi	(bar)	psi	(bar)	lbf	(kN)
K3 ALL MODELS	8 - 16	(30 - 60)	2,610	(180)	3,110	(214)	164,110	(730)

MODELS	WEIGHT		MAXIMUM JAW OPENING		CUTTER BLADE LENGTH	
	lbs.	(kg)	in	(mm)	in	(mm)
K3JFR	815	370	14	355	8.5	215
K3JR	890	405	14	355	8.5	215
K3JREH	1090	495	14	355	8.5	215

# SPECIFICATIONS

## K4J SHEAR

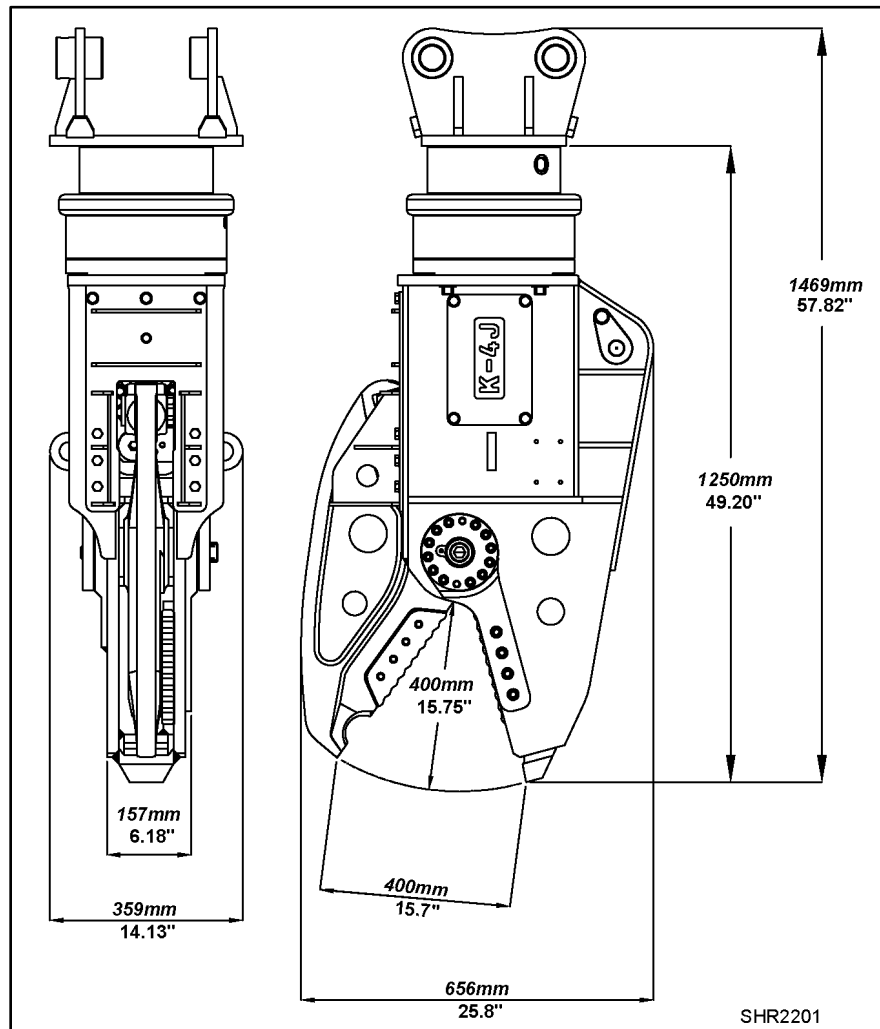

MODELS	OIL FLOW		OPERATING PRESSURE		CIRCUIT RELIEF minimum		MAXIMUM CUTTING FORCE	
	gpm	(lpm)	psi	(bar)	psi	(bar)	lbf	(kN)
K4 ALL MODELS	8 - 19	(30 - 70)	2,610	(180)	3,110	(214)	179,850	(800)

MODELS	WEIGHT		MAXIMUM JAW OPENING		CUTTER BLADE LENGTH	
	lbs.	(kg)	in	(mm)	in	(mm)
K4JFR	975	(440)	15.7	(400)	10.2	(260)
K4JR	1,050	(475)	15.7	(400)	10.2	(260)
K4JREH	1,250	(565)	15.7	(400)	10.2	(260)

# SPECIFICATIONS

## K7J SHEAR

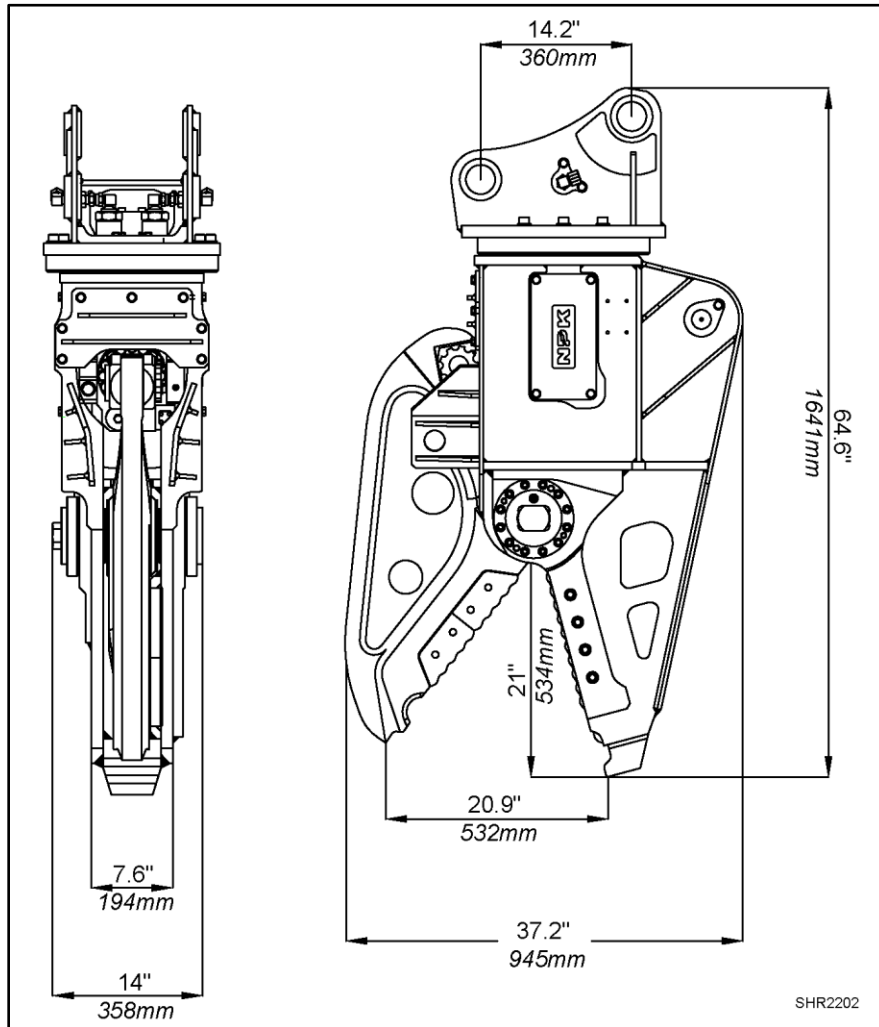

MODELS	OIL FLOW		OPERATING PRESSURE		CIRCUIT RELIEF minimum		MAXIMUM CUTTING FORCE	
	gpm	(lpm)	psi	(bar)	psi	(bar)	lbf	(kN)
K7 ALL MODELS	13 - 34	(50 - 130)	3,045	(210)	3,545	(244)	290,000	(1,290)

MODELS	WEIGHT		MAXIMUM JAW OPENING		CUTTER BLADE LENGTH	
	lbs.	(kg)	in	(mm)	in	(mm)
K7JFR	1,700	(770)	20.9	(532)	13.4	(340)
K7JR	1,780	(810)	20.9	(532)	13.4	(340)
K7JREH	1,820	(825)	20.9	(532)	13.4	(340)

# SPECIFICATIONS

## ROTATION UNIT: K3JR, K4JR, K7JR

There are three options of rotation for the K-Series. Examples of rotation options are depicted below.

“JFR”	Mechanical Free Rotation
“JR”	Full Hydraulic Rotation
“JREH”	Electro/Hydraulic Rotation

### “JFR”

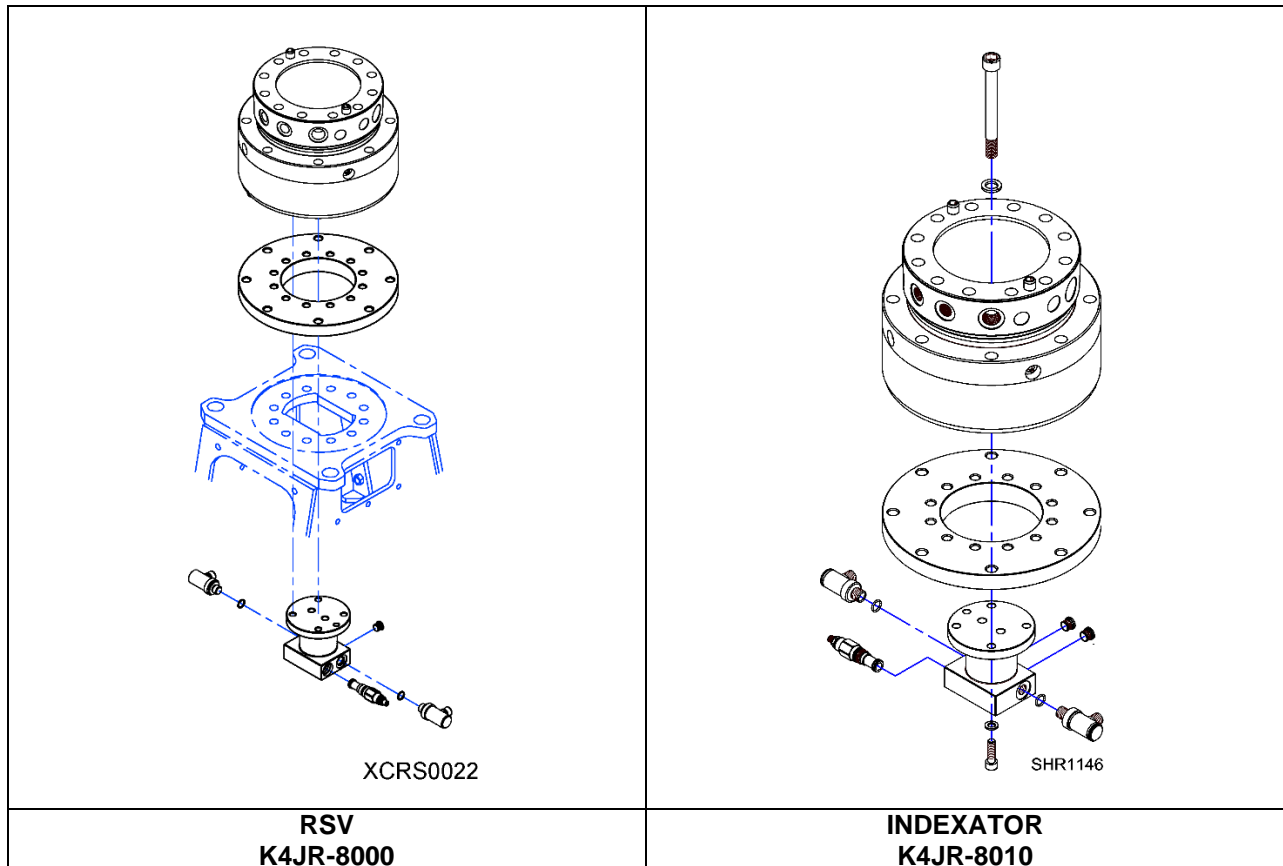
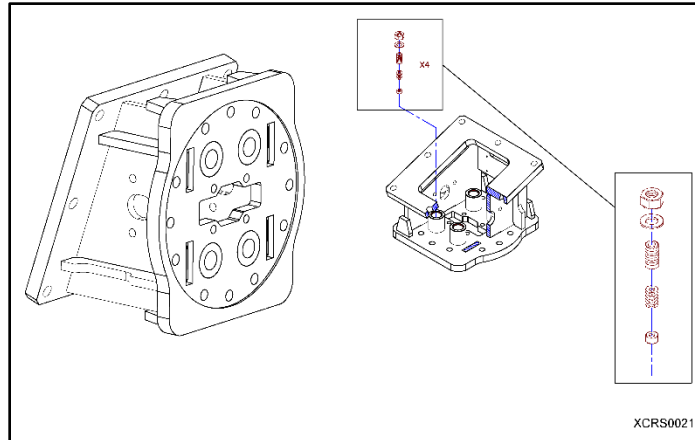

**RSV  
K4JR-8000**

**INDEXATOR  
K4JR-8010**



# SPECIFICATIONS

## ROTATION UNIT: K3JR, K4JR, K7JR

### BEARING AND MOTOR (K7JR ONLY)

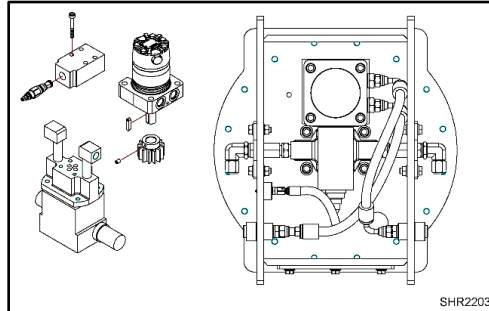

### ELECTRO-HYDRAULIC (ALL MODELS)

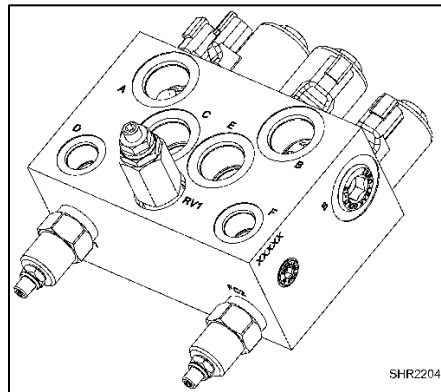

### HYDRAULIC ROTATION

ROTATOR	MODELS	ROTATION SPEED	OIL FLOW		PRESSURE	
		rpm	gpm	(lpm)	psi	(bar)
XR300	K3JR	10 - 20	2.5 - 5	(9.5 - 19)	2,030	140
	K4JR	10 - 20	2.5 - 5	(9.5 - 19)	2,030	140
Motor/Bearing	K7JR	14 - 18	3 - 4	(12 - 15)	1,450 - 2,030	100 - 140

### ELECTRO-HYDRAULIC ROTATION

MODELS	ROTATION SPEED	OIL FLOW		PRESSURE	
	rpm	gpm	(lpm)	psi	(bar)
K3JREH	14	3.5	(13)	1,800	(140)
K4JREH	14	3.5	(13)	1,800	(140)
K7JREH	15.5	3.5	(13)	1,800	(124)

**\*Cross port relief valves are part of the rotation hydraulic circuit on the carrier.**

# MECHANICAL ROTATION STOPPER

## INSPECTION AND REPLACEMENT OF STOPPER

Check the rotation every three months and exchange the following parts as needed:

- Unfasten the hex nut (C1) and remove the set screw (c6). Once completed, use an M6 bolt to remove the spring (bs26) and stopper (m31).
- Inspect the stopper (m31), if the thickness becomes less than *10mm*, it requires replacement. Newer stoppers are *15mm*.
- Inspect the spring (bs26). If there is a crack or chip, it also requires replacement.

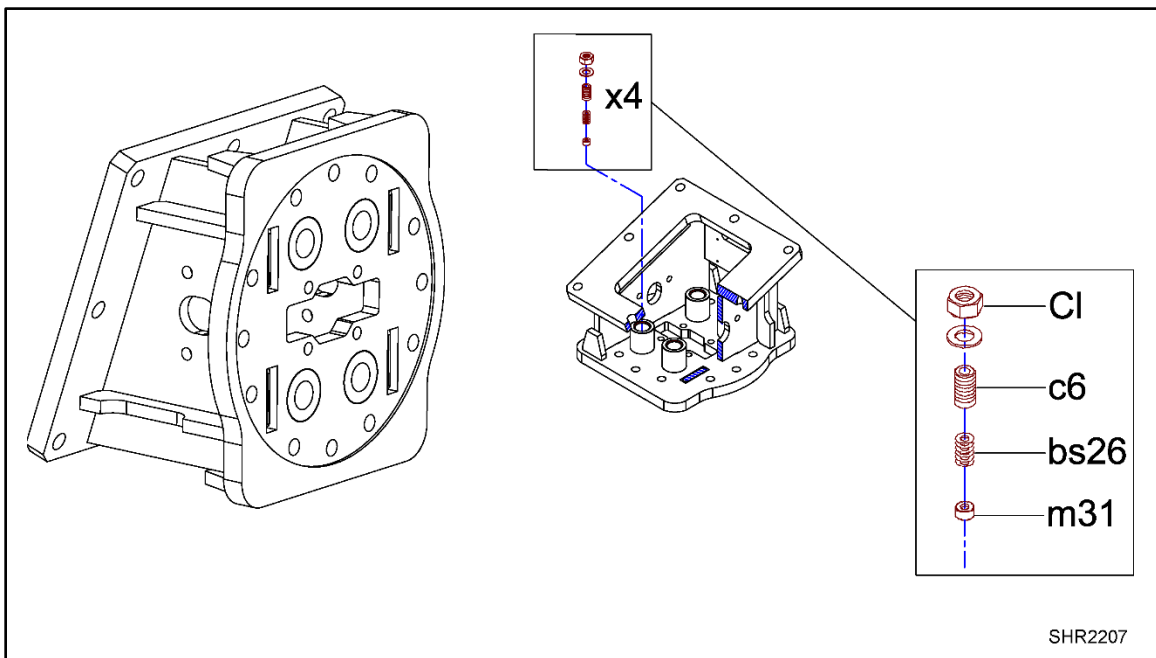

# CUTTING FORCE

The cutting force at point d97 for the K3JR Shear, when cutting 1-1/2" (38.1mm) steel bar, is 45 US tons (40 metric tons).

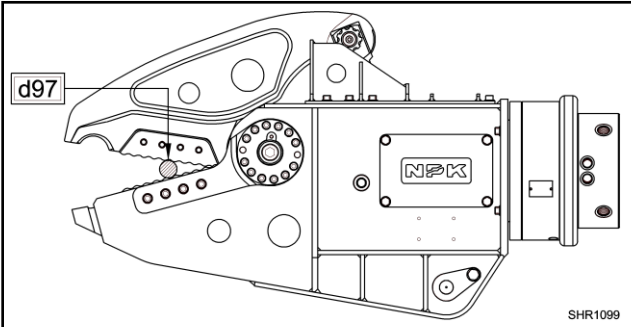

The cutting force at point d97 for the K4JR Shear, when cutting 1-3/4" (44.45mm) steel bar, is 65 US tons (59 metric tons).

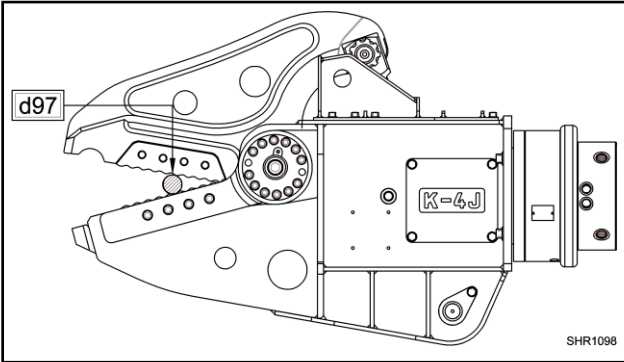

The cutting force at point d97 for the K7JR Shear, when cutting 2" (50.8mm) steel bar, is 77 US tons (70 metric tons).

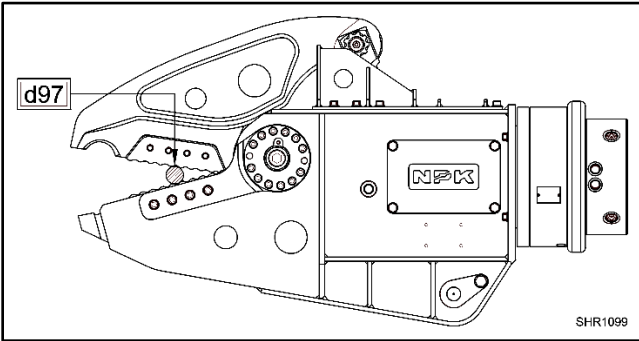

# JAW CUTTING CAPACITY

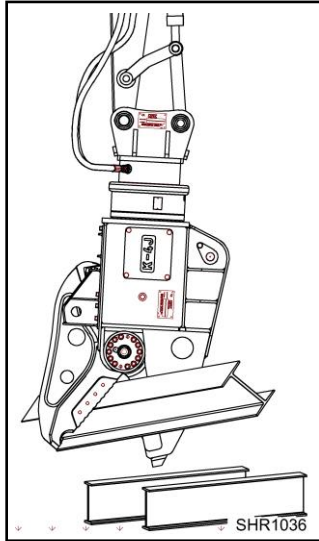

**NOTE:** Cutting capacities listed below are based on a single pass cut. Larger material can be cut using multiple pass cuts.

## APPETITE GUIDE: MILD STEEL

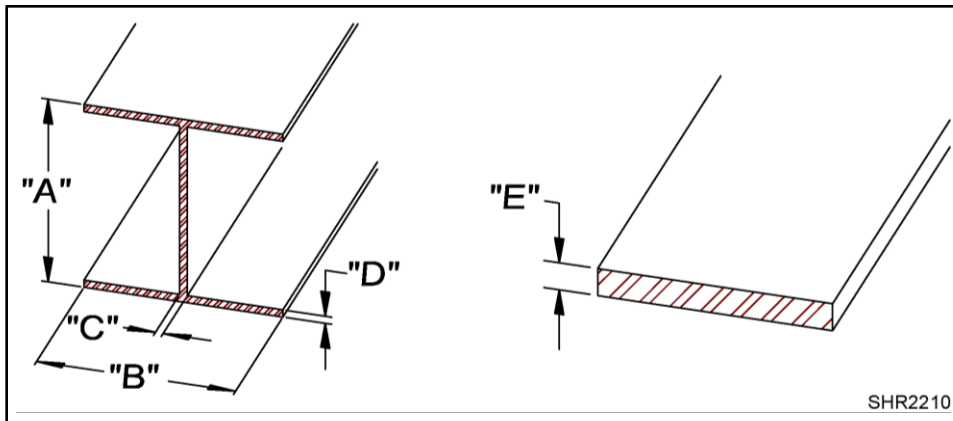

MODEL	A		B		C		D	
	in	(mm)	in	(mm)	in	(mm)	in	(mm)
K3J	3.94	(100)	1.97	(50)	.20	(5)	.28	(7)
K4J	4.92	(125)	2.36	(60)	.24	(6)	.31	(8)
K7J	6.89	(175)	3.54	(90)	.20	(5)	.31	(8)

MODEL	E	
	in	(mm)
K3J	.50	(13)
K4J	.65	(16)
K7J	.75	(19)

# SERIAL NUMBER LOCATION

---

K3J / K4J / K7J

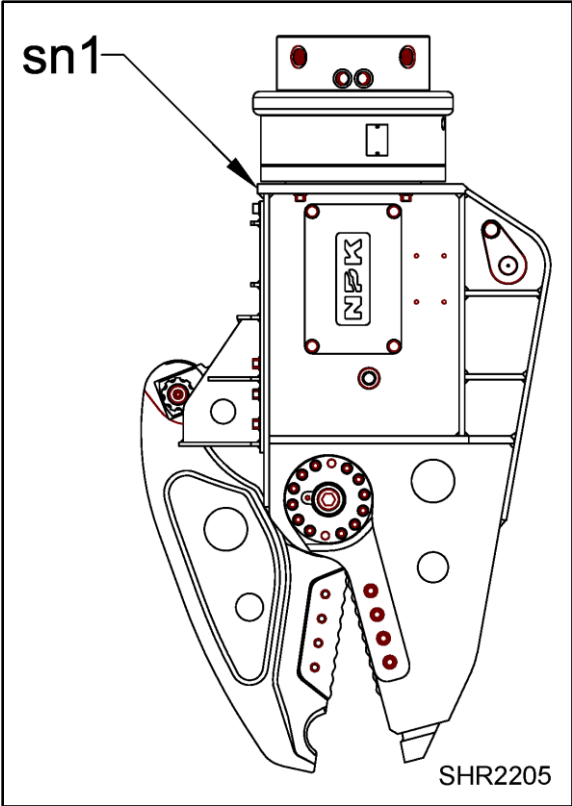

# SHEAR BOOSTER CYLINDER

## I INTRODUCTION

The hydraulic cylinder used on the NPK Shear is equipped with a built-in hydraulic booster. To close the moveable jaw of the shear, hydraulic oil from the carrier is directed to the base end of the cylinder, which extends the cylinder rod. Under no load, no boost is applied, and this results in a rapid cycle time as compared to large, non-boosted cylinders.

When a load (*material to be sheared*) is encountered, the oil is directed into the booster section, which intensifies the pressure well beyond the system operating pressure of the carrier. The compact NPK Booster Cylinder System provides a working force equal to a far larger non-boosted cylinder, which is working at carrier system pressure. Because the NPK boosted cylinder is smaller, it requires less oil for full stroke as compared to a large diameter cylinder. This reduces cycle time for the NPK Shear. To open the jaw of the Shear, oil is directed to the rod end of the cylinder. This retracts the cylinder rod and pulls the jaw open. No boost is provided in the jaw open mode.

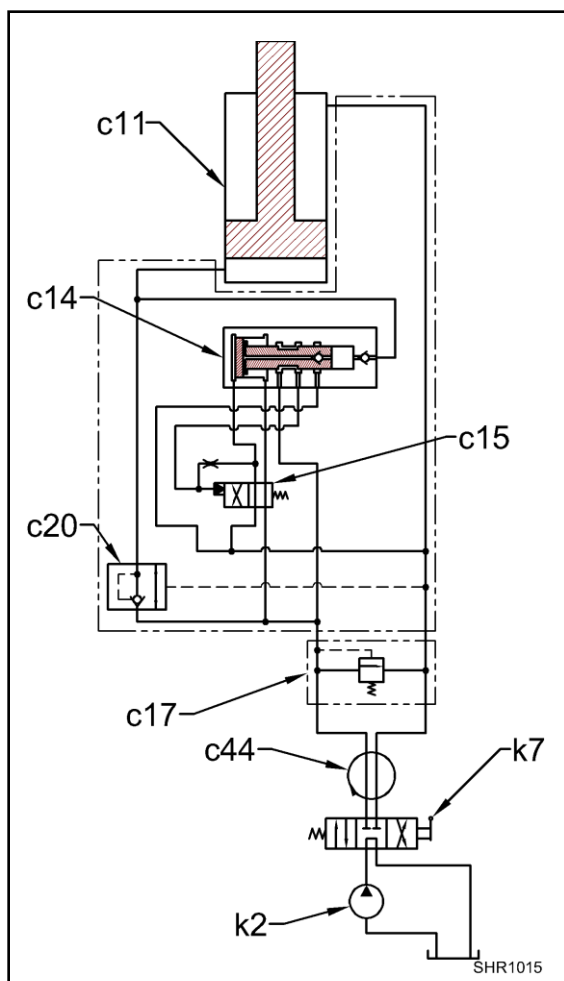

c11	JAW CYLINDER
c14	PRESSURE INTENSIFIER
c15	MAIN VALVE ASSEMBLY
c17	RELIEF VALVE (jaw close)
c20	PILOT CHECK VALVE
c44	ROTATION HEAD
k2	CARRIER HYDRAULIC PUMP
k7	CARRIER CONTROL VALVE

# SHEAR BOOSTER CYLINDER

## II STRUCTURE OF THE BOOSTER CYLINDER

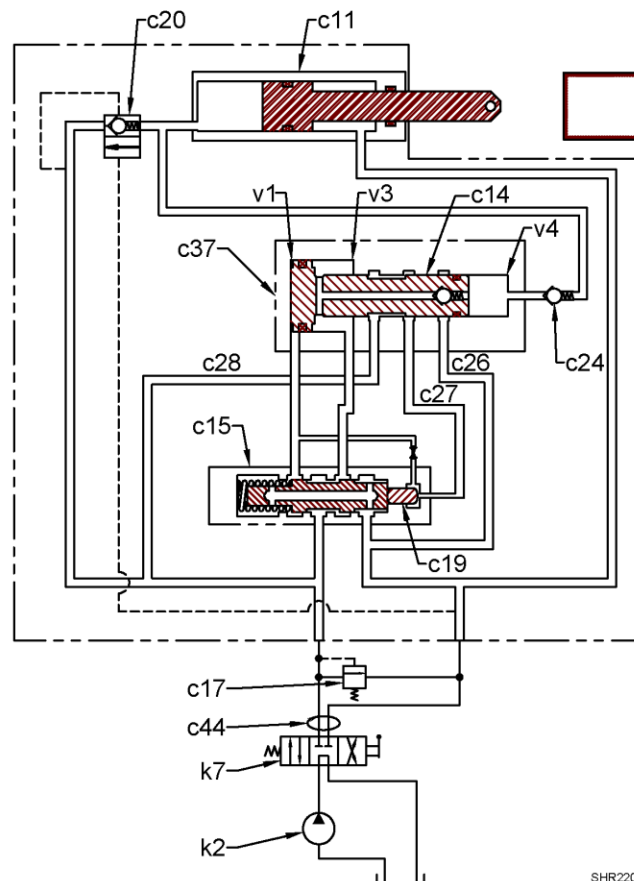

**Fig. 1**

As shown in **Fig. 1**, the booster cylinder assembly consists of: see the column to the right.

For a complete breakdown of the parts in the boosted cylinder assembly, see the parts manual for each unit by serial number.

c11	JAW CYLINDER
c14	BOOSTER PISTON
c15	MAIN VALVE ASSEMBLY
c17	RELIEF VALVE (jaw close)
c19	PLUNGER
c20	PILOT CHECK VALVE
c24	CHECK VALVE
c26	PORT C1
c27	PORT C2
c28	PORT C3
c37	INTENSIFIER ASSEMBLY
c44	ROTATION HEAD
k2	CARRIER HYDRAULIC PUMP
k7	CARRIER CONTROL VALVE
v1	OIL CHAMBER
v3	OIL CHAMBER
v4	OIL CHAMBER

# SHEAR BOOSTER CYLINDER

## III OPERATING PRINCIPLE

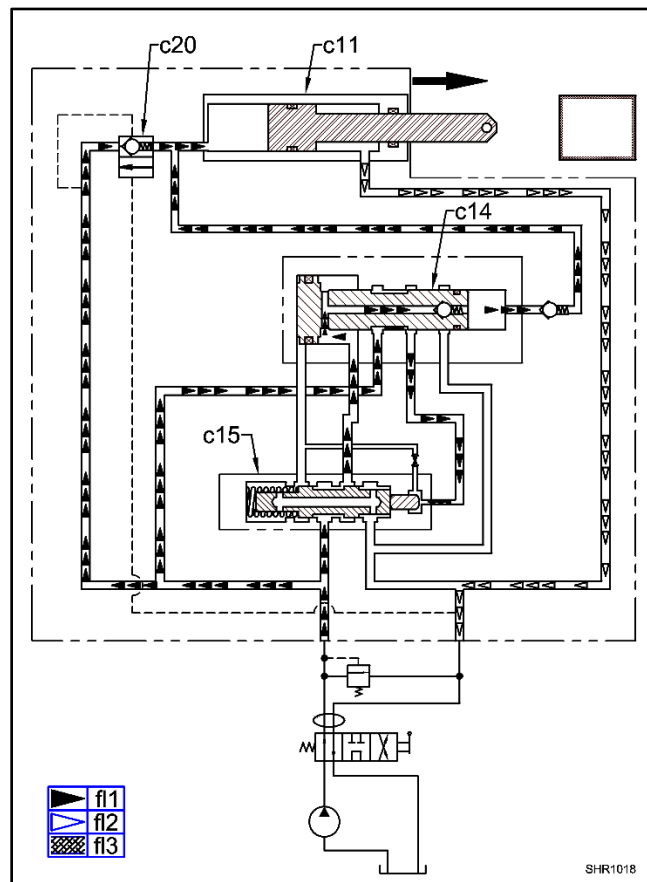

**FIG. 2 CYLINDER EXTEND (NO LOAD)**

When the cylinder (c11) is extended (jaw close) and no load (*material to be sheared*) is encountered, oil is directed to the base end of the cylinder by way of the pilot check valve (c20). Oil also travels to the base end of the cylinder through the main valve (c15) and the booster piston (c14). When there is no load condition, hydraulic pressure is low, and no boosted pressure is required.

c11	JAW CYLINDER
c14	BOOSTER PISTON
c15	MAIN VALVE ASSEMBLY
c20	PILOT CHECK VALVE
f1	HIGH PRESSURE HYDRAULIC FLOW
f2	LOW PRESSURE HYDRAULIC FLOW
f3	INTENSIFIED HYDRAULIC FLOW



# SHEAR BOOSTER CYLINDER

## III OPERATING PRINCIPLE

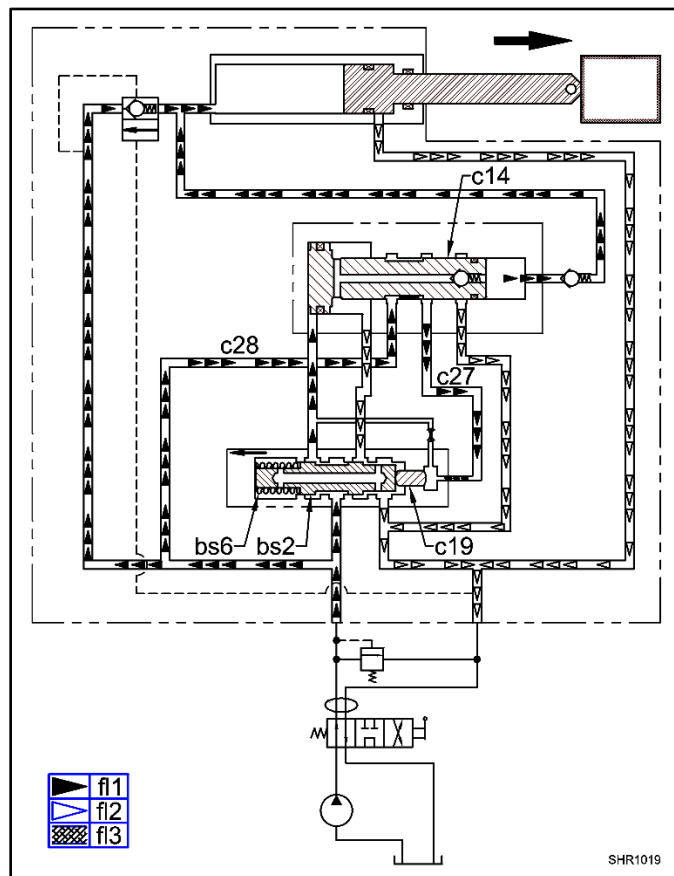

**FIG. 3 BOOSTER ACTUATION**

At this time, the booster piston (c14) is at full reverse stroke. When a load is encountered on the jaw close cycle, the hydraulic pressure begins to rise in port C28 of the booster piston which is connected to port C27. Pressure from port C27 moves the plunger (c19) causing the main valve spool (bs2) to shift against the spring (bs6).

bs2	MAIN VALVE SPOOL
bs6	SPRING
c14	BOOSTER PISTON
c19	PLUNGER
c27	PORT
c28	PORT
f1	HIGH PRESSURE HYDRAULIC FLOW
f2	LOW PRESSURE HYDRAULIC FLOW
f3	INTENSIFIED HYDRAULIC FLOW

# SHEAR BOOSTER CYLINDER

## III OPERATING PRINCIPLE

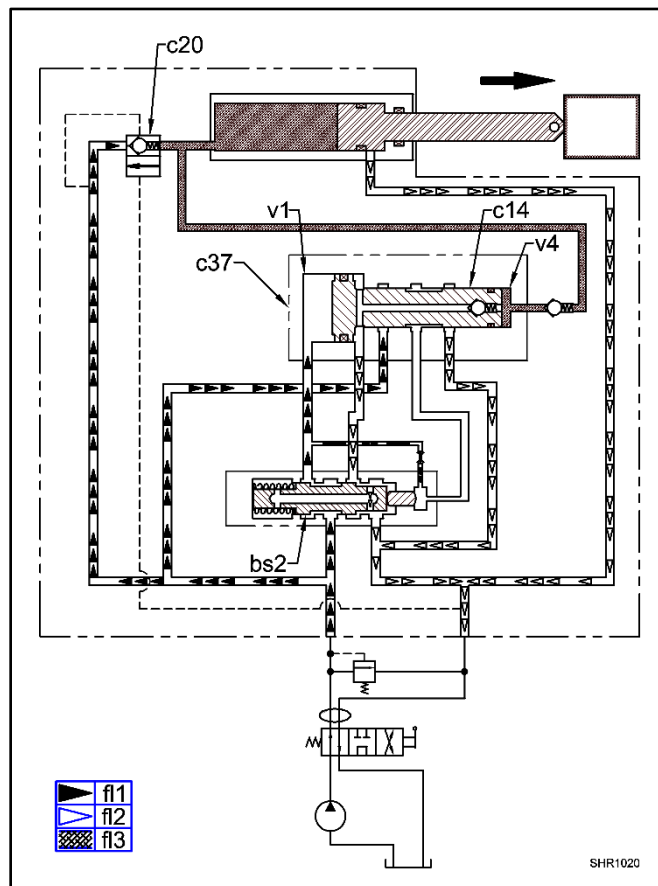

**FIG. 4 FORWARD PISTON STROKE**

The main valve spool (bs2) re-directs the hydraulic oil to the **v1** chamber of the intensifier assembly (c37) and strokes the booster piston (c14) toward chamber **v4**. Because the area of the piston in chamber **v1** is greater than in area in chamber **v4**, the hydraulic pressure in area **v4** is intensified. This higher-pressure oil is pushed through **v4** to the base end of the cylinder. The pilot check (c20) is closed at this time, blocking the intensified pressure from being released to the hydraulic reservoir.

bs2	MAIN VALVE SPOOL
c14	BOOSTER PISTON
c20	PILOT CHECK VALVE
c37	INTENSIFIER ASSEMBLY
f1	HIGH PRESSURE HYDRAULIC FLOW
f2	LOW PRESSURE HYDRAULIC FLOW
f3	INTENSIFIED HYDRAULIC FLOW
v1	OIL CHAMBER
v4	OIL CHAMBER

# SHEAR BOOSTER CYLINDER

## III OPERATING PRINCIPLE

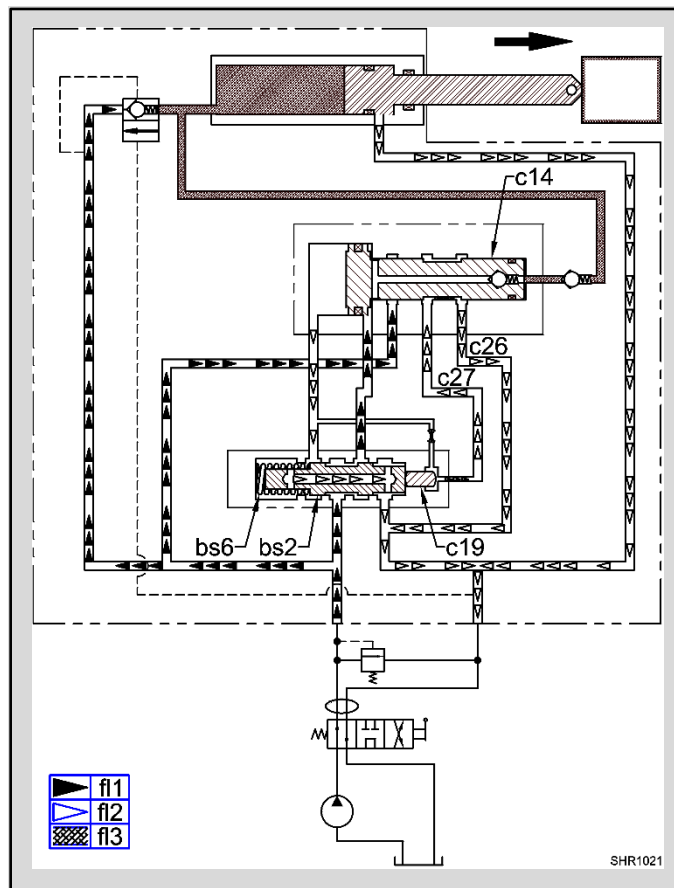

**FIG. 5 VALVE SHIFT TO REVERSE STROKE**

When the booster piston (c14) reaches full stroke, oil from port “C2” (c27) is connected to port “C1” (c26), releasing oil from the plunger (c19) area allowing the spring (bs6) to shift the main spool (bs2) back to a rest position.

bs2	MAIN VALVE SPOOL
bs6	SPRING
c14	BOOSTER PISTON
c19	PLUNGER
c26	PORT C1
c27	PORT C2
f1	HIGH PRESSURE HYDRAULIC FLOW
f2	LOW PRESSURE HYDRAULIC FLOW
f3	INTENSIFIED HYDRAULIC FLOW

# SHEAR BOOSTER CYLINDER

## III OPERATING PRINCIPLE

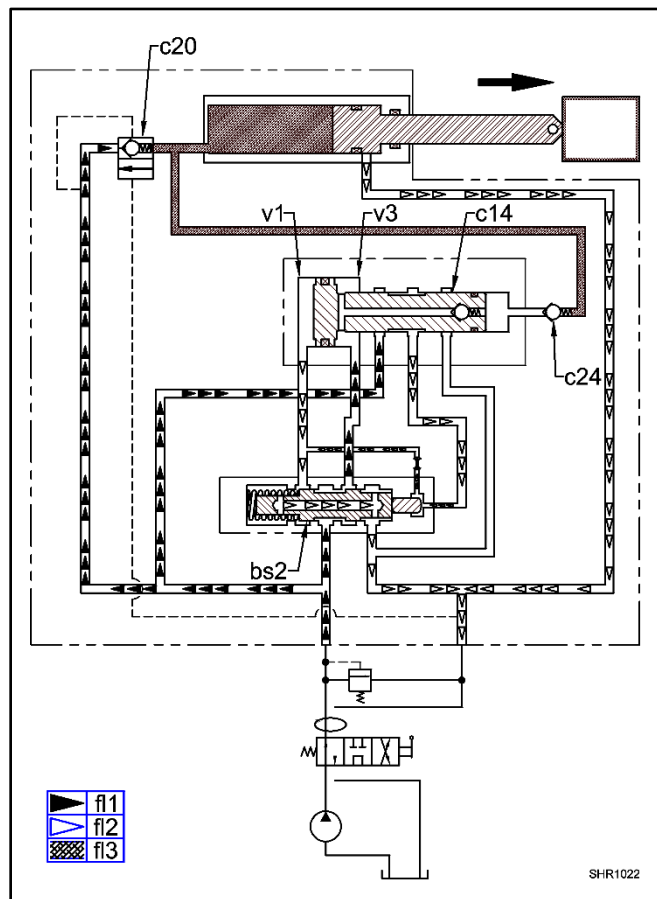

**FIG. 6 REVERSE PISTON STROKE**

When the main control valve spool (bs2) has been shifted, oil is directed to chamber **v3**. Oil in chamber **v1** is released to the hydraulic reservoir. The booster piston (c14) now starts its reverse stroke. Intensified pressure is trapped by the pilot check (c20) and two check valve (c24).

bs2	MAIN VALVE SPOOL
c14	BOOSTER PISTON
c20	PILOT CHECK VALVE
c24	CHECK VALVE
f1	HIGH PRESSURE HYDRAULIC FLOW
f2	LOW PRESSURE HYDRAULIC FLOW
f3	INTENSIFIED HYDRAULIC FLOW
v1	OIL CHAMBER
v3	OIL CHAMBER

# SHEAR BOOSTER CYLINDER

## III OPERATING PRINCIPLE

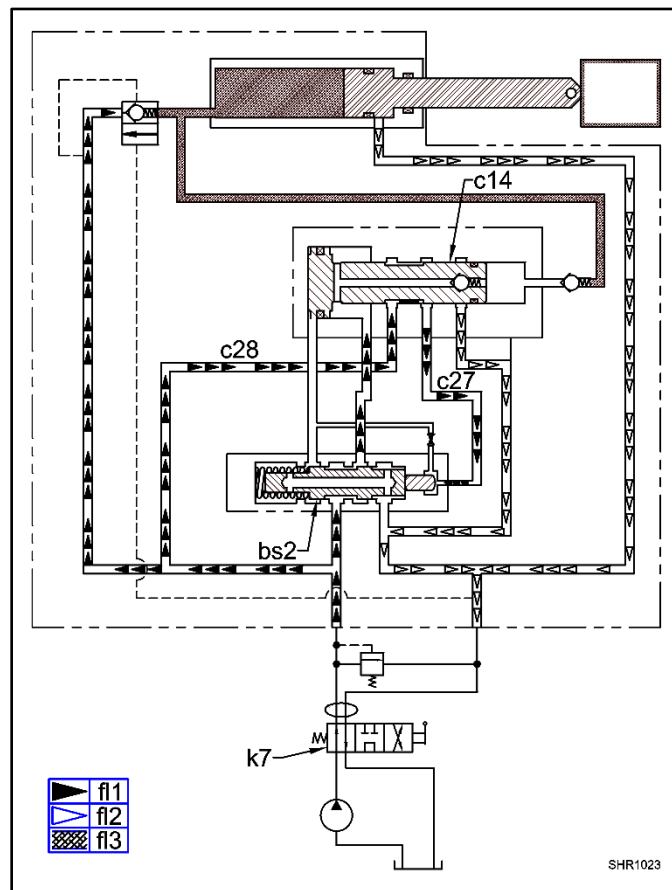

**FIG. 7 VALVE SHIFT TO FORWARD STROKE**

When the booster piston (c14) reaches full reverse stroke, oil from port “C3” (c28) is open to port “C2” (c27). This allows the main valve spool (bs2) to be stroked to allow oil to the booster piston to start the next forward piston stroke. These forward and reverse booster piston strokes will continue as long as the carrier’s control valve (k7) is shifted (*into jaw close mode*) and there is sufficient resistance (*load*) to shearing to keep the booster active.

bs2	MAIN VALVE SPOOL
c14	BOOSTER PISTON
c27	PORT C2
c28	PORT C3
f1	HIGH PRESSURE HYDRAULIC FLOW
f2	LOW PRESSURE HYDRAULIC FLOW
f3	INTENSIFIED HYDRAULIC FLOW
k7	CARRIER CONTROL VALVE

# SHEAR BOOSTER CYLINDER

## III OPERATING PRINCIPLE

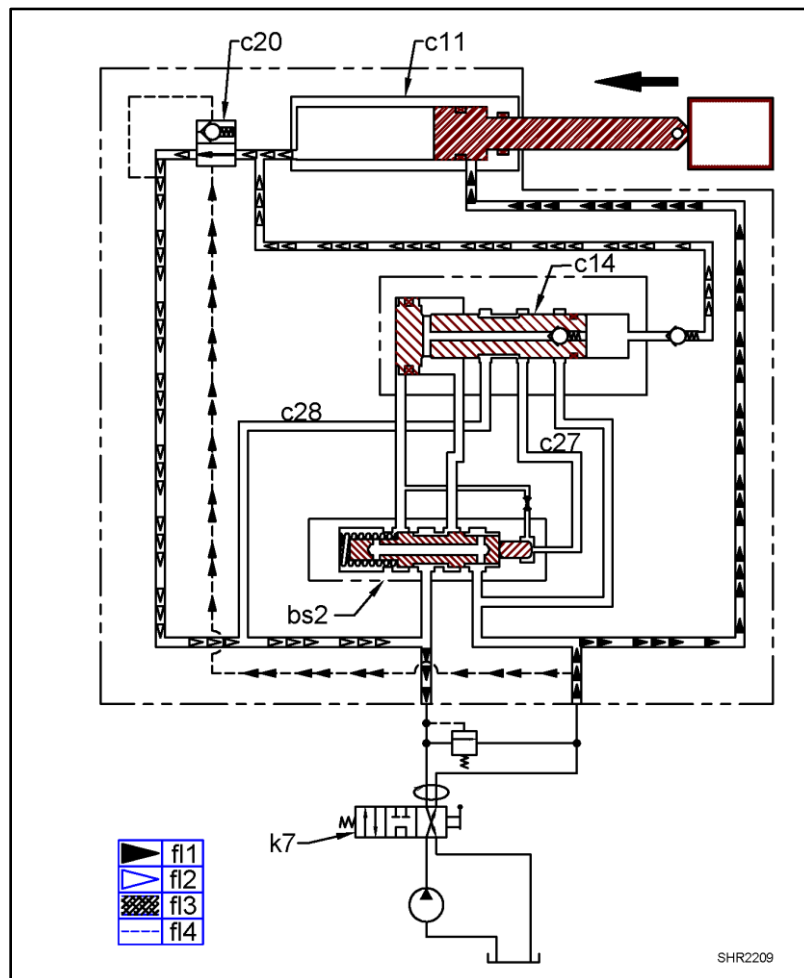

**FIG. 8 VALVE SHIFT, CYLINDER RETRACT (JAW OPEN)**

When the jaw cylinder (c11) is opened, oil from the control valve (k7) of the carrier is directed through the booster to the rod end of the cylinder. A pilot signal from this flow is sent to the pilot check valve (c20). This opens the pilot check allowing intensified pressure to be released and oil to be pushed out of the base end of the cylinder.

bs2	MAIN VALVE SPOOL
c14	BOOSTER PISTON
c27	PORT C2
c28	PORT C3
f1	HIGH PRESSURE HYDRAULIC FLOW
f2	LOW PRESSURE HYDRAULIC FLOW
f3	INTENSIFIED HYDRAULIC FLOW
k7	CARRIER CONTROL VALVE

# SHEAR BOOSTER CYLINDER

## III OPERATING PRINCIPLE

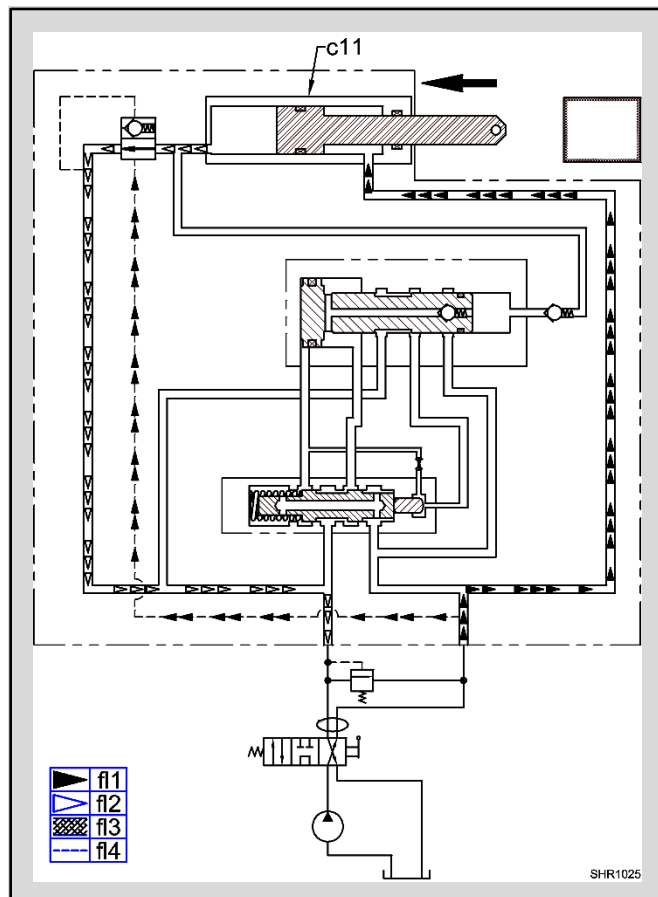

**FIG. 9 CYLINDER RETRACT (JAW OPEN)**

As the cylinder (c11) rod retracts, the jaw will open. There is no boost when the cylinder rod retracts, and the jaw opens.

c11	JAW CYLINDER
f1	HIGH PRESSURE HYDRAULIC FLOW
f2	LOW PRESSURE HYDRAULIC FLOW
f3	INTENSIFIED HYDRAULIC FLOW
f4	PILOT FLOW

# HYDRAULIC INSTALLATION

## FLOW DIRECTION

The hydraulic flow to close (m3) the shear jaws is on the left side of the carrier (looking from the operator's seat) and to open (m4) the jaws is on the right.

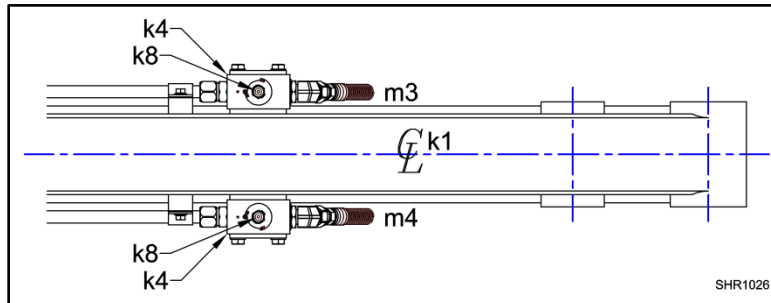

## SHUT-OFF VALVES

Most Hydraulic Installation Kits use two shut-off valves (k4) on the stick (k1) of the carrier. Each shut-off valve has an “ON” (k5) and an “OFF” (k6) position. Make sure both shut-off valves are turned to the “ON” position before operating the crusher.

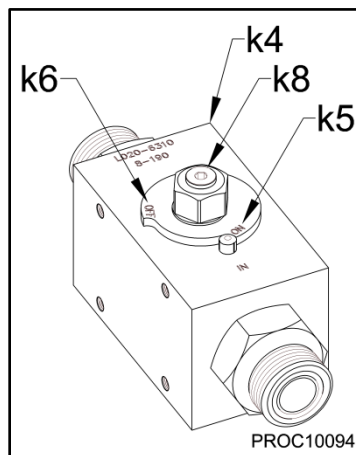

### NOTE:

*A pressure test (gauge) port (k8) is located in both shut-off valve spools.*



# HYDRAULIC INSTALLATION

## HYDRAULIC QUICK DISCONNECTS

NPK prefers the use of a straight JIC connection (39) when installing its shear onto a carrier.

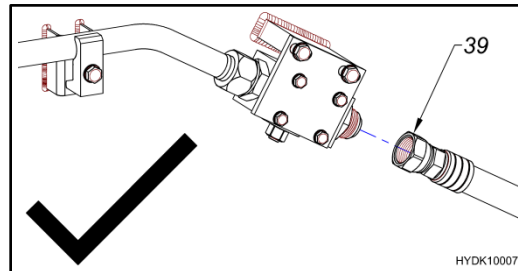

**NOTE:** Care should be given when removing the shear to make sure that the hoses are plugged, and the tube ends are capped to prevent contamination from entering the hydraulic system.

NPK recommends against the use of non-NPK hydraulic quick disconnects on fluid circuits operating NPK Products, including shear, for the following reasons:

1. The hydraulic pulsations caused by the shear can cause internal pieces of the non-NPK quick disconnect (32) to disintegrate. These pieces can migrate into the shear, causing damage to the unit. That damage is not covered by NPK's warranty.

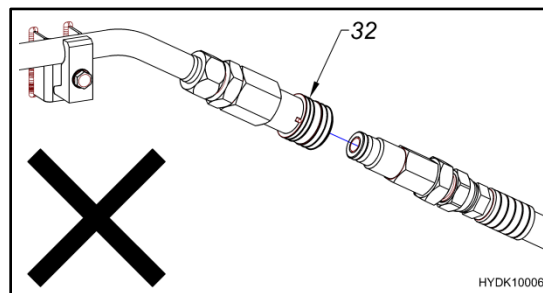

2. Contamination can enter the hydraulic system if the quick disconnect ends are not kept clean. The quick disconnects should be capped to keep them clean. If this is not done, contamination in the quick disconnect will be flushed into the hydraulic system, causing internal damage to the shear.
3. Most quick disconnects create a restriction in the hydraulic circuit. NPK Shears are not pressure sensitive, but the restrictions cause unnecessary heating of the oil. Also, the pressure required to operate the shear, plus the restriction of the quick disconnects may push an older, lower pressure carrier to the limit of its hydraulic system. This would interfere with the proper operation of the shear. However, the NPK approved quick disconnects are properly sized so that the shear operation is not affected.

# HYDRAULIC INSTALLATION

## HYDRAULIC QUICK DISCONNECTS

NPK has approved quick disconnects. Contact your NPK dealer or NPK direct at 440-232-7900 for proper sizing of approved NPK quick disconnects for your unit.

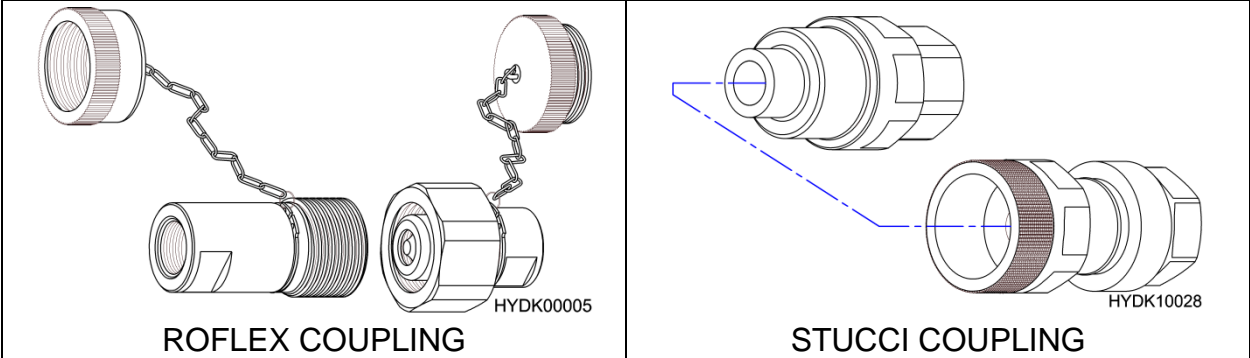

# HYDRAULIC INSTALLATION

---

## PREVENTION OF CONTAMINATION

### ATTENTION

1. Neglect of the hydraulic oil will cause many problems in all of the hydraulic components, including the attachment. Care should be taken to check for contamination of the oil and to change the oil if contamination is found. ***Routine oil sampling is recommended once per month.***

- ❖ When the hydraulic oil shows low viscosity and bubbles, this indicates that the oil is deteriorated. If the oil is dark brown and gives off an offensive odor, it is severely deteriorated. ***Change the oil immediately!***
- ❖ When the oil is clouded, or the oil filter becomes clogged, it indicates that the oil is contaminated. ***Change the oil immediately!***
- ❖ To change the contaminated hydraulic oil, drain the hydraulic system as completely as possible. Try to minimize the amount of old oil that will be mixed with the new oil.

**NOTE:** *It is suggested to change the oil in the system with all of the cylinders retracted.*

**NOTE:** *If a catastrophic failure has occurred and the system is found to have metal mixed with the hydraulic oil, a complete disassembly and clean out must be done to ALL hydraulic components and attachments. ALL of the hydraulic lines must be flushed.*

2. Do not allow any contaminants to mix with the hydraulic oil. Take special care in preventing contamination from entering the hydraulic system through the hose or tube connection when installing or removing the attachment. Always have caps and plugs ready.
3. Low oil level will cause heat buildup, resulting in deterioration of the hydraulic oil. Also, it may cause pump cavitation due to air mixing with the oil, leading to damage to the attachment or the carrier components. Keep the oil at the proper level at all times.
4. Do not use the shear at an operating temperature higher than 180°F (80°C). The proper operating oil temperature range is between 120°F (50°C) and 180°F (80°C). Since contaminated cooler fins cause reduced efficiency of the cooler, keep them clean at all times. The use of a heat gun is the best way to evaluate if the cooler is working properly.
5. Water in the hydraulic oil will lead to damage of the attachment and the carrier. Drain off water and foreign matter from the hydraulic tank at specified intervals. When out of service, the attachment should be stored indoors.

# MOUNTING INSTALLATION

## MOUNTING INSTALLATION KIT

NPK pin on and hook style Mounting Installation Kits include the parts required to adapt the NPK Shear to the stick or arm of the carrier. The pin on type kits includes all necessary stick and link pins, bushings, spacers, etc.

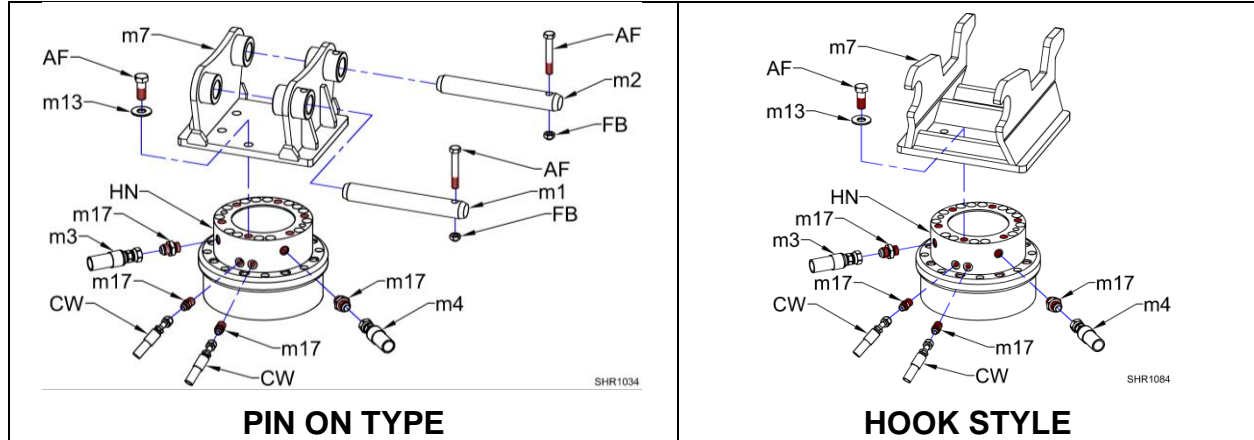

<b>AF</b>	HEX HEAD BOLT
<b>CW</b>	ROTATION HOSE
<b>FB</b>	STOVER NUT
<b>HN</b>	ROTATION HEAD
<b>m1</b>	STICK PIN
<b>m2</b>	LINK PIN
<b>m3</b>	CLOSE WHIP HOSE
<b>m4</b>	OPEN WHIP HOSE
<b>m7</b>	TOP BRACKET
<b>m13</b>	WASHER
<b>m17</b>	ADAPTER FITTING

<b>AF</b>	HEX HEAD BOLT
<b>CW</b>	ROTATION HOSE
<b>HN</b>	ROTATION HEAD
<b>m3</b>	CLOSE WHIP HOSE
<b>m4</b>	OPEN WHIP HOSE
<b>m7</b>	TOP BRACKET
<b>m13</b>	WASHER
<b>m17</b>	ADAPTER FITTING

*\*Reference page 105 for torque specifications.*

## MOUNTING TO THE CARRIER

1. Position the Shear on wood blocks (t20) as shown.
2. Align the stick pin bore (m24). Install the stick pin (m1).
3. Align the link pin bore (m25). Install the link pin (m2).
4. Clean away any dirt found on the hose connections and connect the whip hoses (m3 and m4).
5. Connect the rotation hoses (CW).
6. Open the shut-off valves (k4).

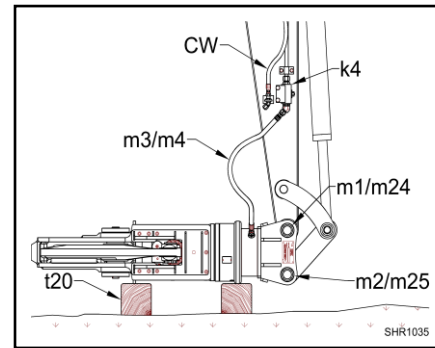

### ATTENTION

*The hydraulic lines (open, close, and rotation) must be handled carefully to prevent contamination from entering the Shear or the carrier hydraulic system.*

# MOUNTING INSTALLATION

---

## REMOVAL FROM THE CARRIER

1. Retract the cylinder to open the moveable jaw fully.
2. Shut off the engine and relieve all hydraulic pressure.
3. Close the shut-off valves.
4. Disconnect all hydraulic hoses before laying the shear down. Immediately install plugs in the hydraulic hoses and cap the hose connections at the end of the stick tubes to keep out contamination.
5. Position the shear horizontal on wood blocks, as shown on previous page.
6. Remove the link pin first, then the stick pin.

## STORAGE OF THE SHEAR

---

1. Make sure all whip hoses (m38) that connect the Shear to the carrier are plugged (AS) and all hose connections are capped (AR). Turn shut-off valves to the “off” position.

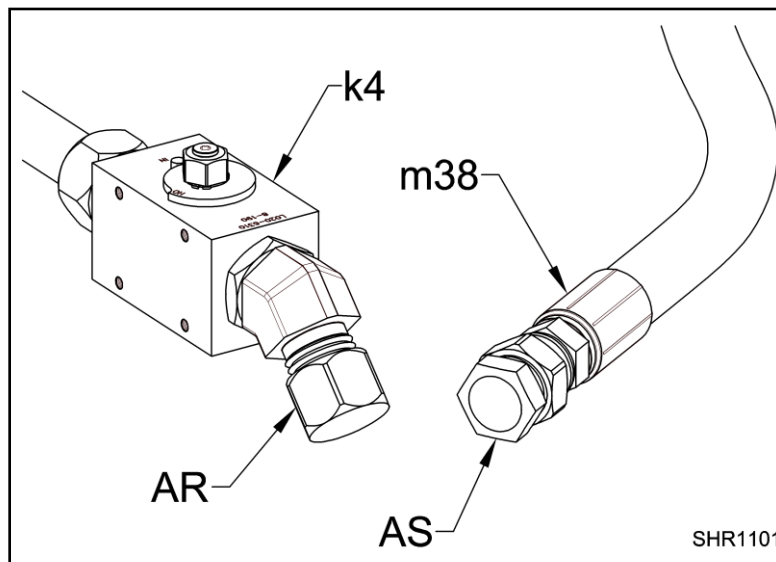

2. Grease all lubrication points; see “**GENERAL MAINTENANCE**” section under “**LUBRICATION POINTS**”.
3. If the unit is stored outdoors, retract the cylinder and cover with a waterproof tarp.

# HOSE INSTALLATION

## HOSE INSTALLATION TIPS

1. Connect larger diameter hoses first. Larger hoses are more difficult to bend and maneuver, while the smaller lines are usually more flexible and easier to install.
2. Do not twist the hose during installation. Pressure applied to a twisted hose can result in premature hose failure or loose connections.

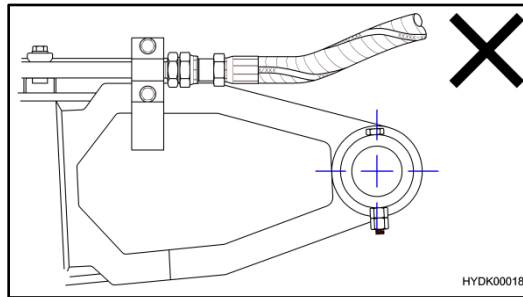

3. Attach both ends of the hose to their connection points. Let the hose find its natural position, then tighten both ends of the hose, using a wrench (t6) and backup wrench (t6a).

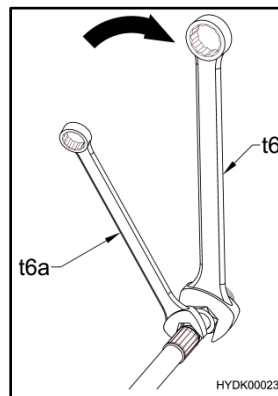

4. Torque hose to specifications.

NOMINAL HOSE SIZE	THREAD SIZE	TORQUE	
		ft. lbs.	(Nm)
1/2"	3/4 - 10	39	(52)
3/4"	1-1/16 - 12	88	(119)
1"	1-5/16 - 12	113	(153)

# HOSE INSTALLATION

## HOSE INSTALLATION TIPS

5. All hoses change in length slightly when pressure is applied. Hoses must have enough slack to relieve stressing the connections.

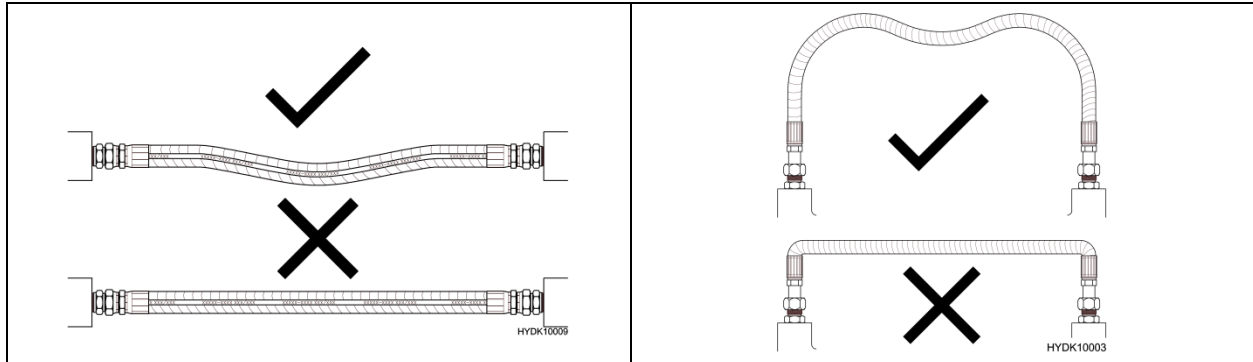

6. Make sure the hose being installed is routed with the proper bend radius to prevent kinking, flow restrictions, or hose failures at the hose connection.

HOSE SIZE	MINIMUM BEND RADIUS	
	in	(mm)
1/2"	7	(177.8)
3/4"	9.5	(241.3)
1"	12	(304.8)

7. Hoses should be used within the following ranges of temperature:

	TEMPERATURE RANGE	
	°F	(°C)
HYDRAULIC FLUID	14 to 176	(-10 to +80)
ATMOSPHERIC	14 to 122	(-10 to +50)

# OPERATING INSTRUCTIONS

Before operating the NPK Shear, be sure to read the safety information and perform the daily and weekly maintenance as specified in this manual.



- **DO NOT OPERATE THE SHEAR WITHOUT DEMOLITION GUARDS IN PLACE!**

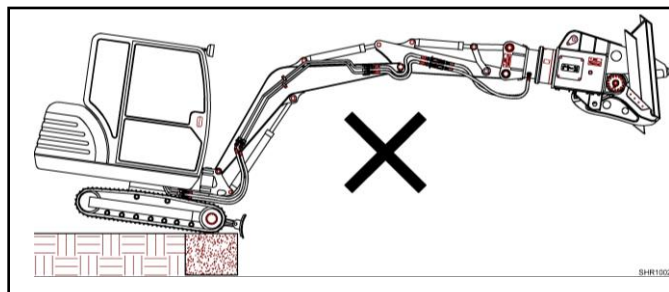

- **DO NOT LIFT OR LOAD BEYOND THE CAPACITY OF THE SHEAR OR THE CARRIER.**
- **USE THE SHEAR ONLY FOR THE APPLICATION FOR WHICH IT WAS INTENDED.**

NPK Shears are designed for the processing of steel, wood, rubber, and plastic scrap, but not concrete.

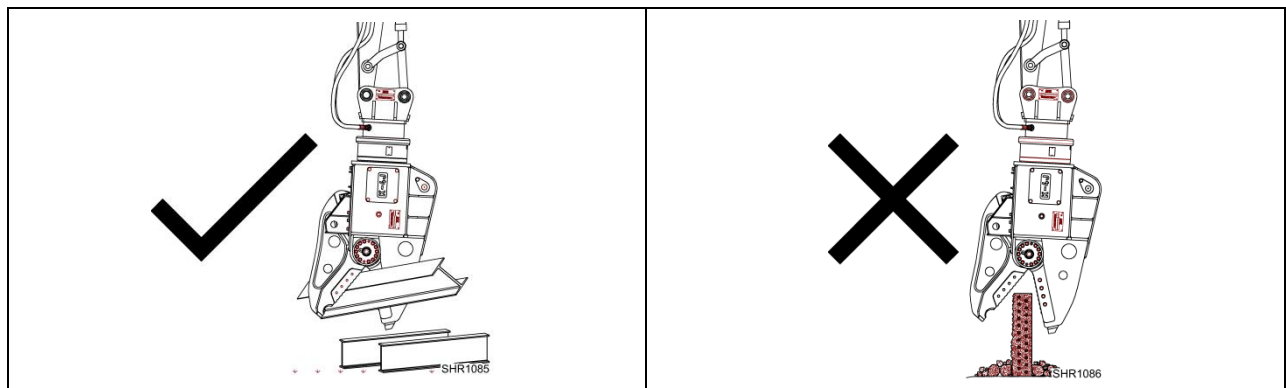



# OPERATING INSTRUCTIONS

## ATTENTION

### OPERATING TECHNIQUES AND PRECAUTIONS

- Do not use the shear with the excavator cylinders fully extended (96) or retracted (97).

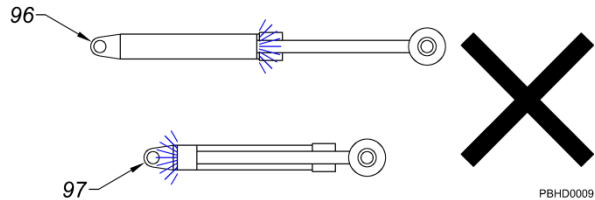

- Do not strike the material with the shear body or outer surface of the jaw. Do not push, pull or scrape material with the shear.

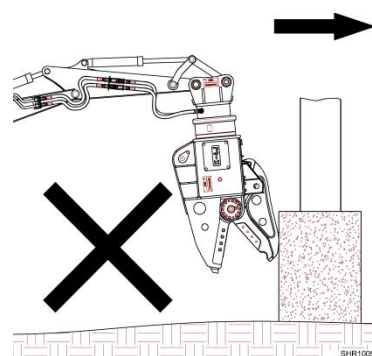
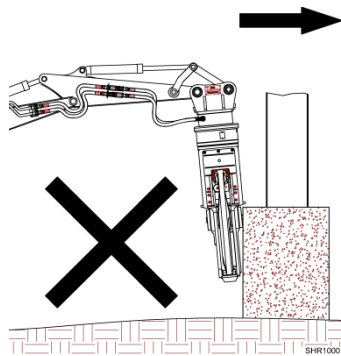

- For most efficient operation, open the jaw only wide enough to grasp the material to be cut.
- Grasp the material (175) to be cut as deep into the throat of the shear as possible. Do not force the material into the jaw.

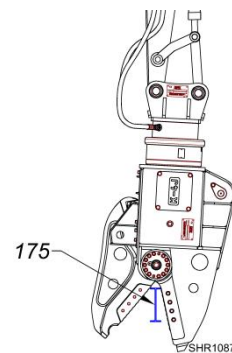

- Position the jaw so that the material is being cut straight on. Do not cut material at an angle. Damage to the main frame or jaw can occur.

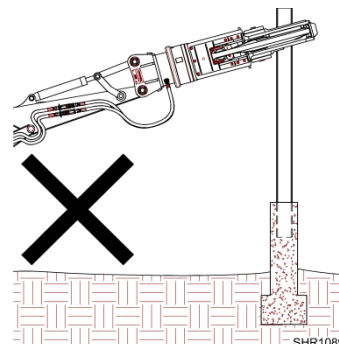
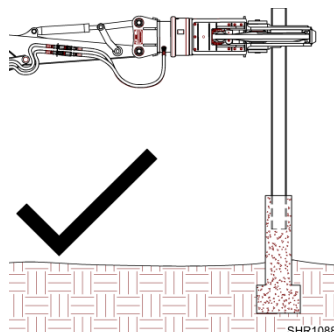

# OPERATING INSTRUCTIONS

## ATTENTION

### OPERATING TECHNIQUES AND PRECAUTIONS

- Do not pry, twist, or pull with the excavator.

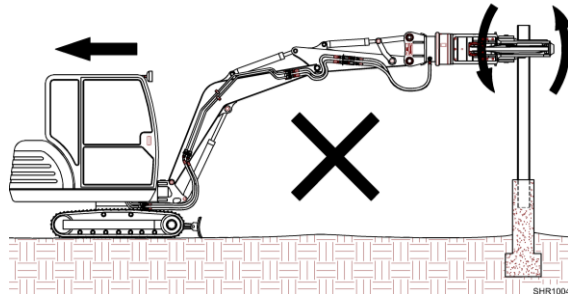

- Allow the hydraulic forces of the Shear jaw to do the work. The excavator is used as a way of positioning the Shear and supplying hydraulic power to the Shear.
- If the material does not cut completely at first, open the jaw and close again in a chewing action.
- Be careful not to cut hard materials. Cutting hard materials will cause the shear blades to crack, chip, or break. Examples of materials not to cut are traveling crane rails, piano wire, high tensile bolt, heat treated steel, etc.
- Do not operate the shear if the hydraulic oil temperature exceeds 176°F (80°C).
- Be very careful of cut steel (174) falling. In a hazardous site, make up a team of two people. One operates the excavator and the other guides the operator for extra safety.

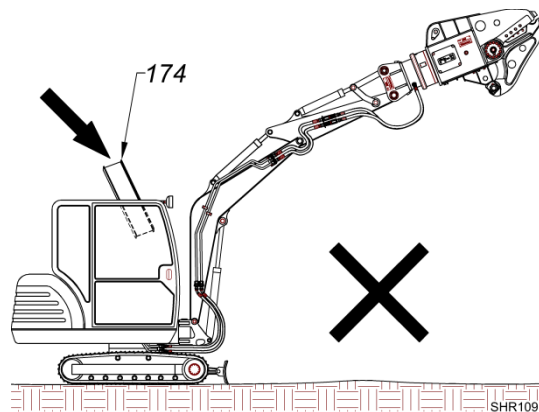
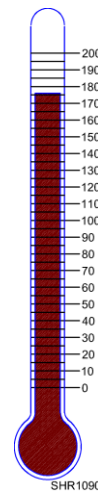

# GENERAL MAINTENANCE

**REFER TO IMPORTANT SAFETY INFORMATION SECTION**

## DAILY INSPECTION AND MAINTENANCE

The functions the shear performs are demanding and in tough environments. Therefore, it is extremely important that the following maintenance and inspection procedures be performed daily.

- Grease all lubrication points! Use moly EP2 or equivalent grease. For lubrication points, see “**GENERAL MAINTENANCE**”, “**LUBRICATION POINTS**”.
- Check for oil leaks at the cylinder piston rod (c3), the machined surfaces (145) and at all of the shear’s hose and fitting connections (hf1).

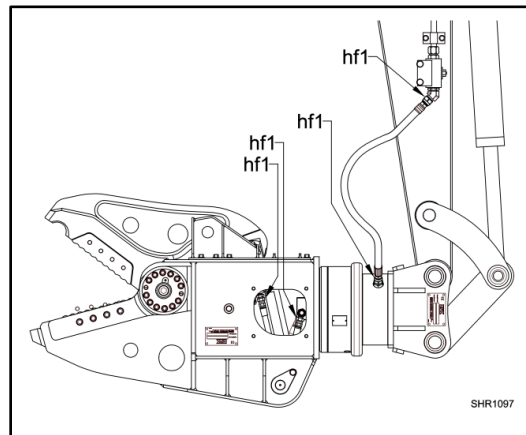
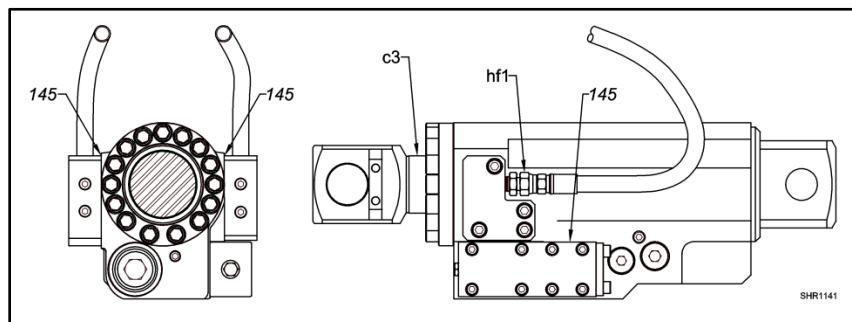

- Inspect the hydraulic hoses for wear, damage, or oil leakage.
- Inspect for loose, broken, and missing fasteners. Replace and/or retighten to torque specifications as required. See the “**FASTENER TORQUE**” section of this manual. Call the NPK Service Department at 440-232-7900 if there are any questions regarding torque.
- Check the moveable jaw and main frame for cracks. See the “**FRAME CRACK AND JAW REPAIR**” section of this manual or contact **NPK** at 440-232-7900 for repair procedure.

# GENERAL MAINTENANCE

---

## REFER TO IMPORTANT SAFETY INFORMATION SECTION

### DAILY INSPECTION AND MAINTENANCE

- Check the condition of the cutting blades (BG). If the edge is rounded or dull, grind the edge back to a sharp 90°

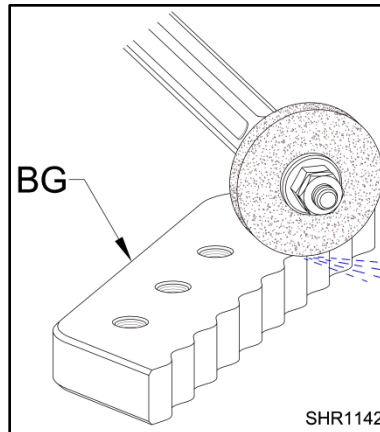

#### **WARNING**

Use care in handling to avoid bodily harm!

#### **CAUTION**

Do not over grind the blades to the point that the surface becomes blue or discolored. This will make the blades brittle.

- Rotate the blades if extreme wear or chipping on the cutting edge is noted. If the blades are replaced or rotated, they must be shimmed. Blades should be shimmed from 0.0157" (0.4 mm) to a maximum of 0.0275" (0.7 mm). Cracked blades must be replaced. (See the "**BLADE MAINTENANCE AND INSTALLATION**" section.)
- Check to ensure that the blade clearance is .000" to .010" (0.00 to 0.25 mm). Reset the blade clearance if necessary (see the "**PIVOT GROUP ADJUSTMENT**" section for instructions.)

# GENERAL MAINTENANCE

## LUBRICATION POINTS – K3JR, K4JR, K7JR

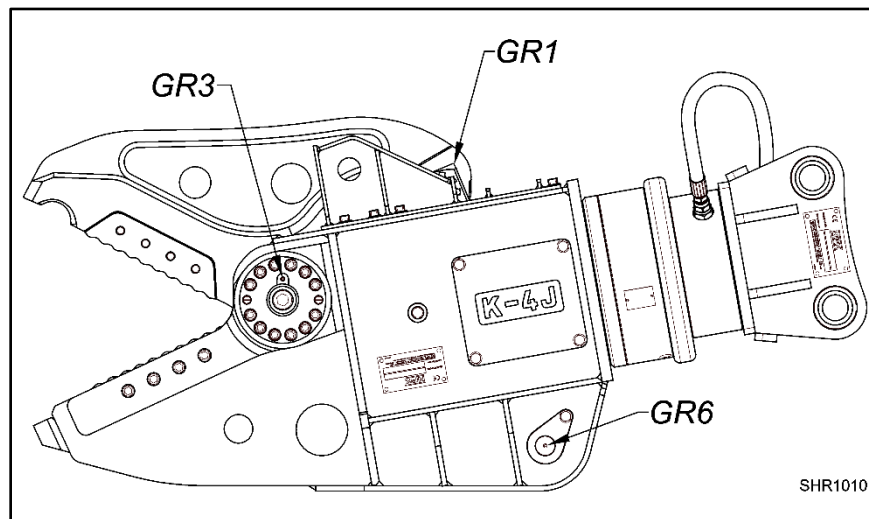

<b>GR1</b>	CYLINDER ROD PIN	One lubrication point located at the jaw attachment end.	10 strokes from a grease gun every 4 hours.
<b>GR3</b>	JAW PIVOT PIN	One lubrication point on each end of the main pivot pin.	15 strokes from a grease gun per fitting every 4 hours.
<b>GR6</b>	CYLINDER BASE END PIN	One lubrication point located at the main frame attachment end.	10 strokes from a grease gun every 4 hours.

# GENERAL MAINTENANCE

## COMPONENT DESCRIPTION – K3JR, K4JR, K7JR

The moveable arm (BD) contains the primary cutting blade (BG), spacer plate (DE).

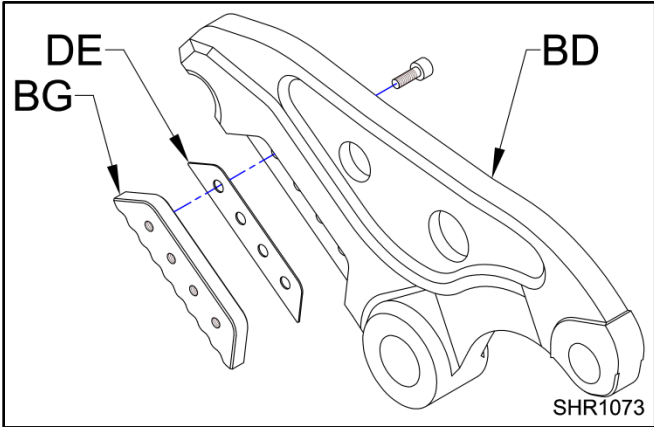

The main frame (BI) contains the secondary blade (BG1) and spacer plate (DE).

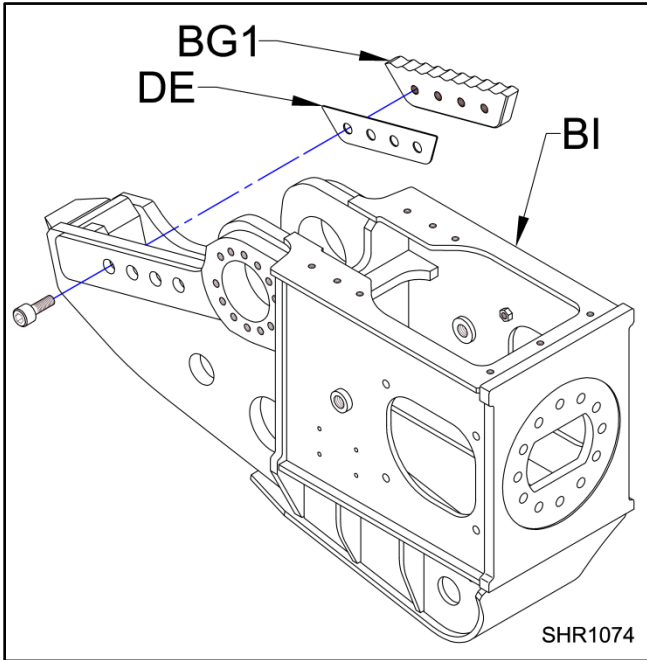

# GENERAL MAINTENANCE

## CUTTER BLADE MAINTENANCE

### BLADE-TO-BLADE CLEARANCE

K3JR, K4JR, K7JR

A blade-to-blade clearance of .0157" to .0275" (0.4 to 0.7mm) should be maintained for optimum performance.

See **Fig. 1** for cutting blade and shim arrangement. Refer to the NPK Parts Manual for part numbers.

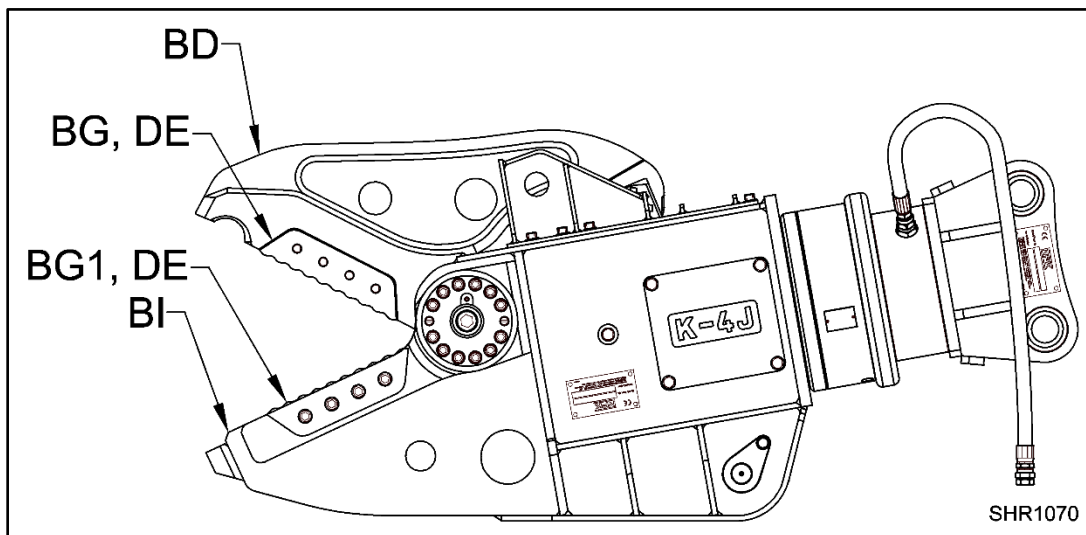

**Fig. 1**

<b>BD</b>	MOVEABLE ARM
<b>BG</b>	PRIMARY CUTTING BLADE
<b>BG1</b>	SECONDARY CUTTING BLADE
<b>BI</b>	MAIN FRAME
<b>DE</b>	SPACER PLATE

**NOTE:** PRIMARY AND SECONDARY BLADES USE THE SAME PART NUMBER (see parts drawing).

# GENERAL MAINTENANCE

## JAW BLADE SET UP PROCEDURE

<b>ST1.</b>	Install the primary blade into the moveable arm first. See “ <b>COMPONENT DESCRIPTION</b> ” and “ <b>MOVEABLE JAW BLADE INSTALLATION</b> ” section, steps 1 through 5.
<b>ST2.</b>	Install the secondary blade in the main frame. Shim to the primary blades. See “ <b>COMPONENT DESCRIPTION</b> ” and “ <b>MAIN FRAME BLADE INSTALLATION</b> ” section, steps 1 through 5.
<b>ST3.</b>	Adjust pivot group. See “ <b>PIVOT GROUP ADJUSTMENT</b> ”, “ <b>PRINCIPAL OF JAW ADJUSTMENT</b> ” and “ <b>ADJUSTMENT PROCEDURE</b> ” section, steps 1 through 17.

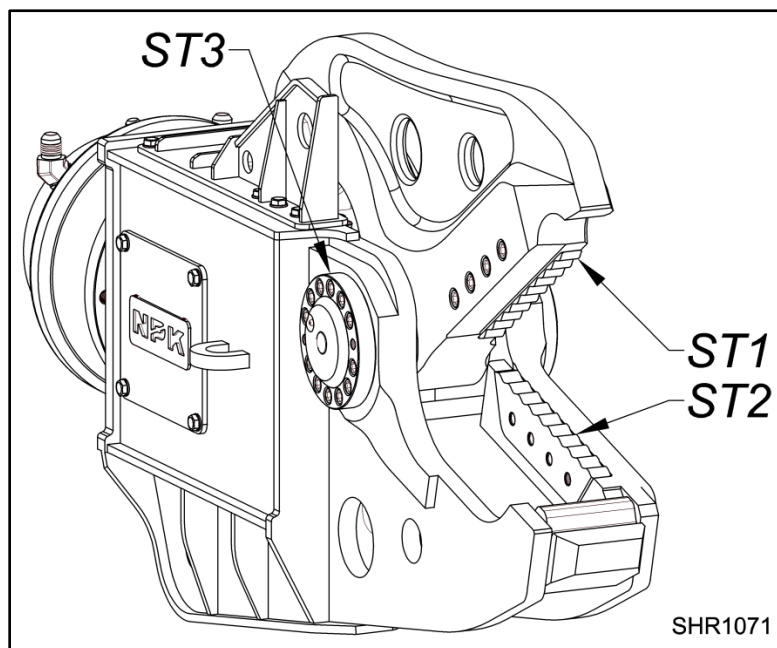



# GENERAL MAINTENANCE

## BLADE INSTALLATION

Each cutting blade can be turned once. When replacing or turning the cutting blades, the following steps must be followed to achieve accurate final blade clearance.

## MOVEABLE JAW BLADE INSTALLATION

1. Prior to the installation of the new or turned blade, the moveable jaw (BD) blade pocket (150) needs to be free from debris and any raised edges. Clean and remove any raised edges from the blade pocket using a grinder (t1). *Clean out all debris.*



*Compressed air can cause injury or death! Limit air pressure to a maximum of 30 psi (2 bar). Protect your eyes with safety glasses! Do not direct compressed air at exposed skin! Do not direct compressed air current at other people within the work area!*

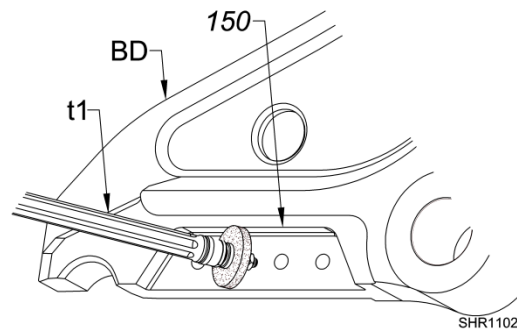

2. If the existing blade (BG) is being reused, the blade face must be free of scars. Remove the scars with a grinder (t1).
3. Check the blade spacer. Make sure it is straight and free of scars.

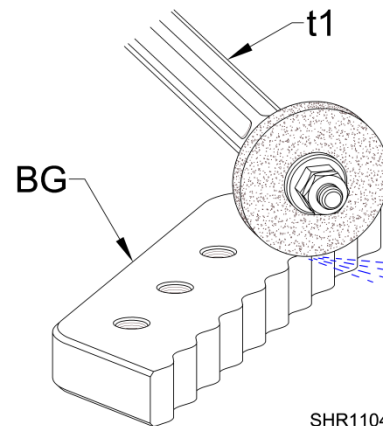

# GENERAL MAINTENANCE

## MOVEABLE JAW BLADE INSTALLATION

4. The primary blade (BD) will have a blade spacer (DE) placed between it and the blade pocket (150). Install and tighten the blade and blade spacer with the four socket head cap screws (OO) threaded into the primary blade.

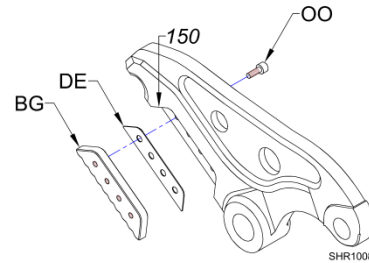

5. Once the primary blade and blade spacer are in place, use thread adhesive (red) (t41) on the socket head cap screws (OO), then torque them to 145 ft. lbs. (200 Nm).

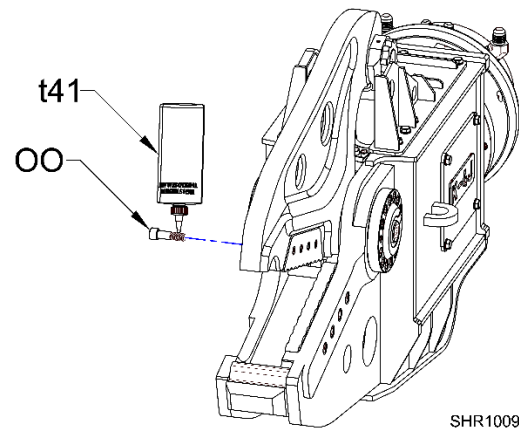

# GENERAL MAINTENANCE

## MAIN FRAME BLADE INSTALLATION

1. Prior to the installation of the new or turned blade, the main frame (BI) blade pocket (150) needs to be free from debris and any raised edges. Clean and remove any raised edges from the blade pocket using a grinder (t1). *Clean out all debris.*

### **WARNING**

*Compressed air can cause injury or death! Limit air pressure to a maximum of 30 psi (2 bar). Protect your eyes with safety glasses! Do not direct compressed air at exposed skin! Do not direct compressed air current at other people within the work area!*

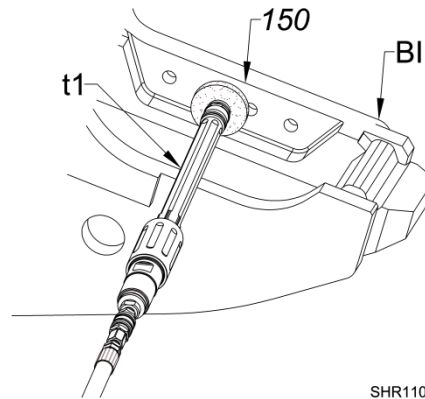

SHR1103

2. If the existing blade (BG) is being reused, the blade face must be free of scars. Remove the scars with a grinder (t1).
3. Check the blade spacer. Make sure it is straight and free of scars.

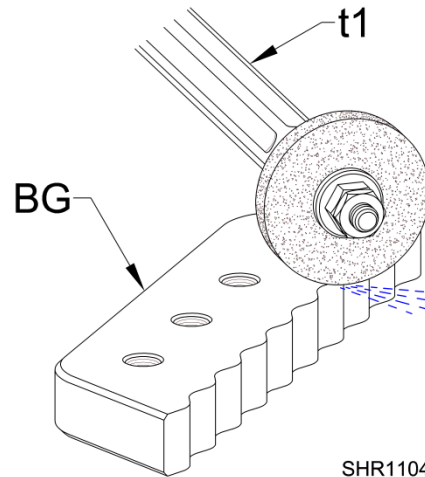

SHR1104

# GENERAL MAINTENANCE

## MAIN FRAME BLADE INSTALLATION

4. The secondary blade (BG1) will also have a blade spacer (DE) placed between it and the blade pocket (150). Install and tighten the blade and blade spacer with the four socket head cap screws (OO) threaded into the secondary blade.

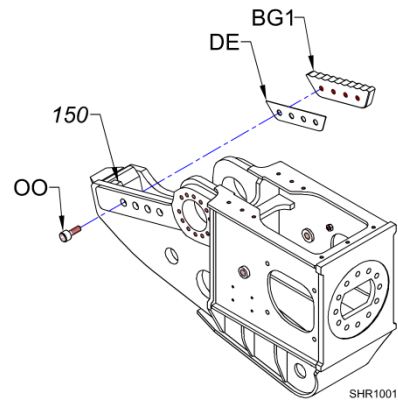

5. Once the secondary blade and blade spacer are in place, use thread adhesive (red) (t41) on the socket head cap screws (OO), then torque them to 145 ft. lbs. (200 Nm).

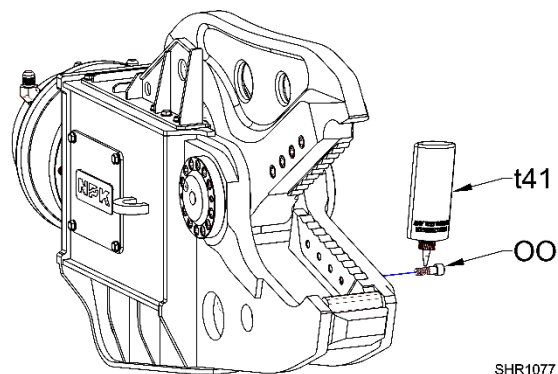

# PIVOT GROUP ADJUSTMENT

---

## PREPARATION

1. Place the shear with the moveable arm facing up and closed.
2. Support the shear assembly (GT) using wood blocks (t20) to prevent it from falling during the adjustment procedure.

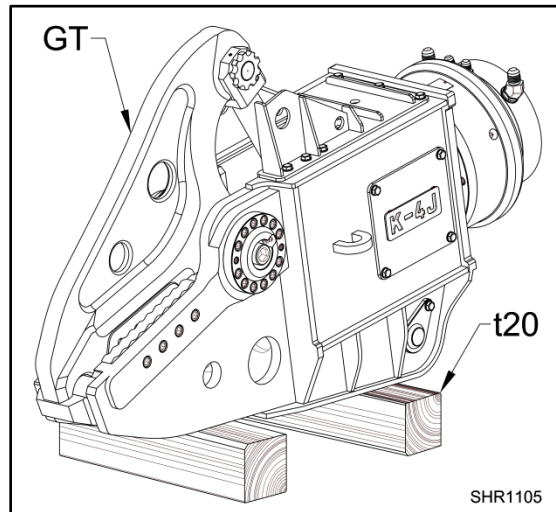

### **WARNING**

**DO NOT** adjust pivot group with the unit resting on unstable ground.

3. Disconnect the booster/cylinder assembly (c38) from the moveable jaw (BD).

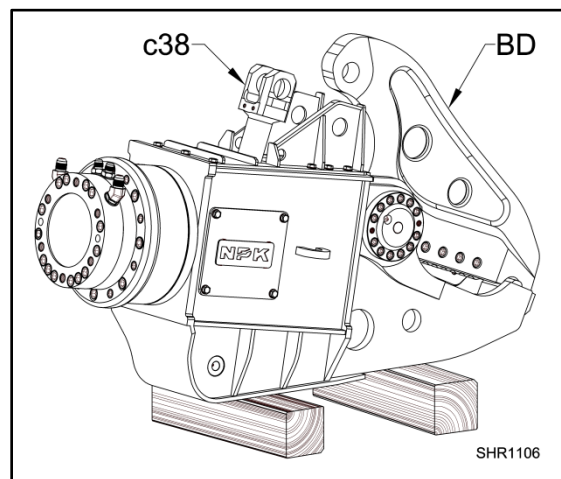

# PIVOT GROUP ADJUSTMENT

## PARTS DESCRIPTION

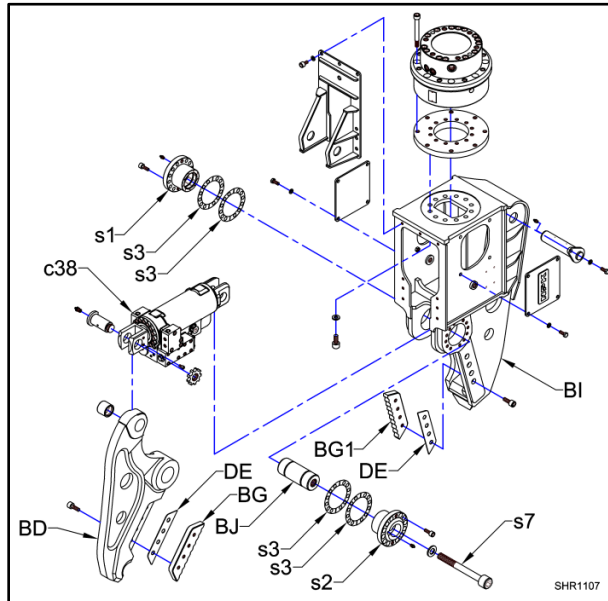

BD	MOVEABLE JAW
BG	PRIMARY CUTTING BLADE
BG1	SECONDARY CUTTING BLADE
BI	MAIN FRAME
BJ	JAW PIVOT PIN
C38	CYLINDER/BOOSTER ASSEMBLY
DE	SPACER PLATE
s1	FLANGE – “A” SIDE
s2	FLANGE – “B” SIDE
s3	PIVOT AREA SHIM
s7	PIVOT PIN BOLT

**NOTE:** *NO shims are required for the moveable jaw or the main frame cutting blades.*

**NOTE:** *Pivot group shim packs are made up of the following thicknesses of shims:*

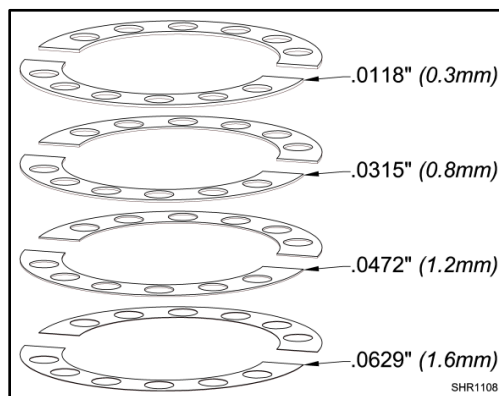

# PIVOT GROUP ADJUSTMENT

## PRINCIPAL OF JAW ADJUSTMENT

The basic principle is to maintain proper clearances (d99 and d100) between the arm (BD) and flange "A" (s1) and flange "B" (s2) while maintaining the clearance (d98) between the primary cutting blade (BG) and the secondary cutting blade (BG1) by changing the thickness of the shims (s3) between the flanges and the frame (BI).

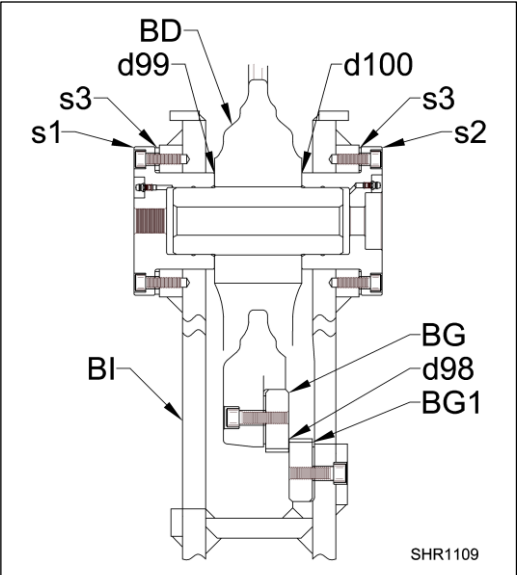

## PROPER CLEARANCES

The following examples show the desired clearances:

d98	CLEARANCE BETWEEN CUTTING BLADES (BG) & (BG1)
d99	CLEARANCE BETWEEN FLANGE "A" (s1) and ARM (BD)
d100	CLEARANCE BETWEEN FLANGE "B" (s2) and ARM (BD)

### Example 1 (Fig. 1)

If clearance d99 is 0 and clearance d100 is .0177" (0.45 mm) clearance d98 will be .010" (0.25 mm).

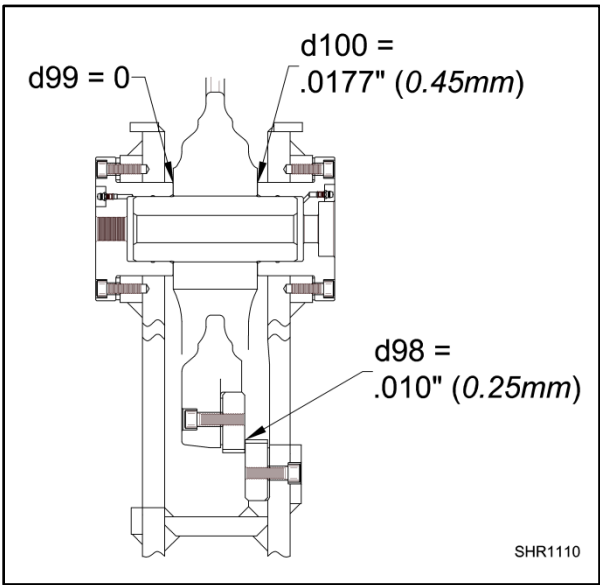

Fig. 1

# PIVOT GROUP ADJUSTMENT

## PRINCIPLE OF JAW ADJUSTMENT

### Example 2 (Fig. 2)

If clearance d100 is 0 and clearance d99 is .0177" (0.45 mm) clearance d98 will be 0.

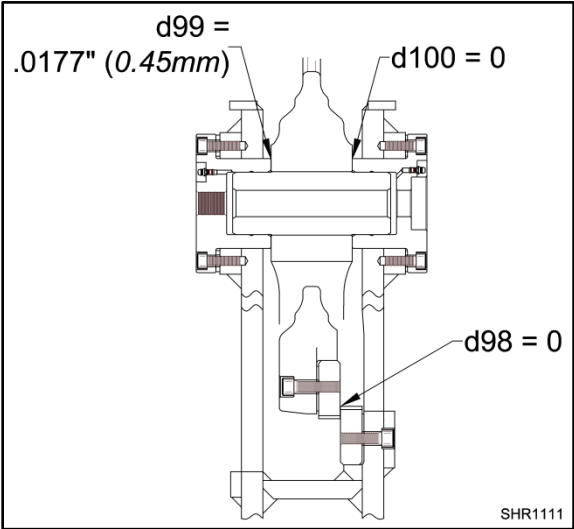

Fig. 2



# PIVOT GROUP ADJUSTMENT

## PRINCIPLE OF JAW ADJUSTMENT

### ATTENTION

To prevent the problems listed below, the clearances listed on page 51 must be set.

1. If the d99 clearance is greater than listed above, the d98 clearance will also be greater. A greater clearance at d98 will result in poor cutting ability.
2. If clearance d98 is greater than clearance d100, the cutter blades will contact each other.
3. If the clearances at d99 and d100 are 0, the arm will rub the surfaces of the flange hard. Rubbing will cause noise, heat buildup and accelerated wear.

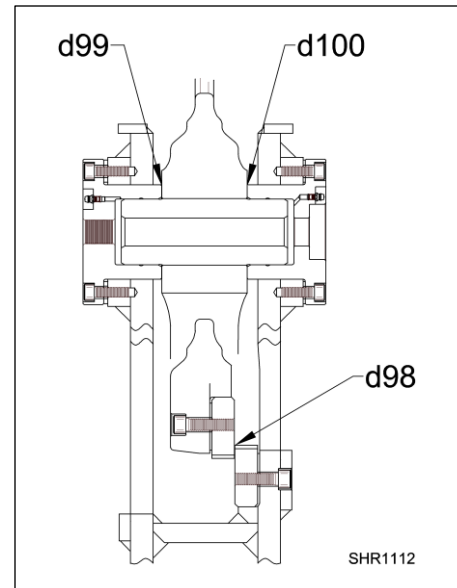

## ADJUSTMENT PROCEDURE

1. Remove pivot pin bolt (s7) from the "B" flange (s2) side of the shear.

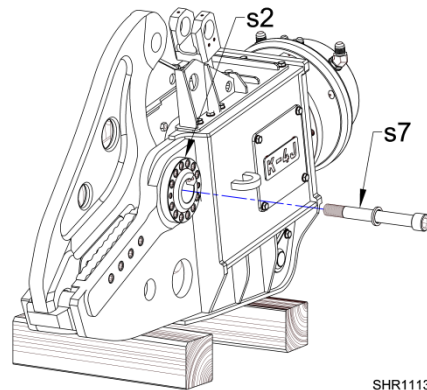

2. Remove the socket head cap screws (OO) that secure the "A" and "B" flanges (s1 and s2) to the frame.

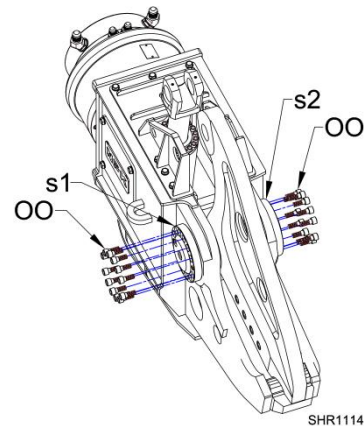

# PIVOT GROUP ADJUSTMENT

## ADJUSTMENT PROCEDURE

3. Install socket head cap screws (OO) into the two tapped holes (49) of the flanges (s1 shown).

K3J	M12 x 60mm LONG
K4J	M14 x 60mm LONG
K7J	M16 x 60mm LONG

- a. Turn the cap screws in one by one.
- b. Pull the flange away from the frame 3/8" to 1/2" (10 to 13mm).

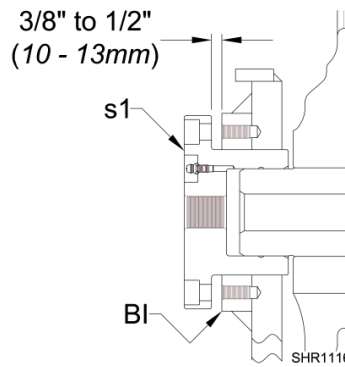
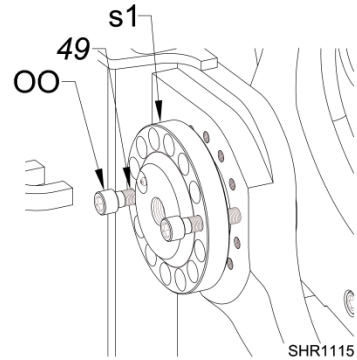

**NOTE:** Do not pull the flange away from the frame more than 1" (25mm). It could cause the flange to pull away from the arm pin.

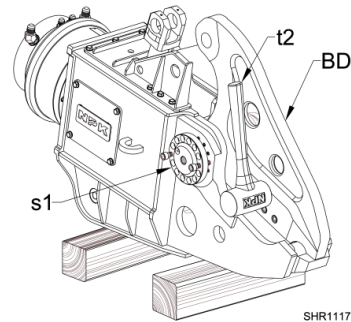

4. Hit the arm (BD) with a dead blow hammer (t2) from the flange "A" (s1) side until the primary cutter blade (BG) is in contact with the secondary cutter blade (BG1). The clearance (d98) between the blades should now be 0.

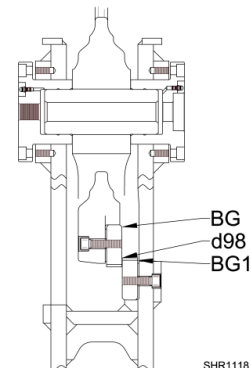

# PIVOT GROUP ADJUSTMENT

## ADJUSTMENT PROCEDURE

5. Make the flange "A" (s1) thrust surface area (31) contact the arm. Set the clearance (d99) to 0.

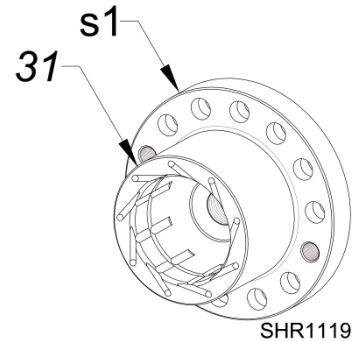

6. Measure the clearance (d101) between the rim of flange "A" (s1) and the frame (BI). Add .0275" (0.7mm) to the measured clearance.

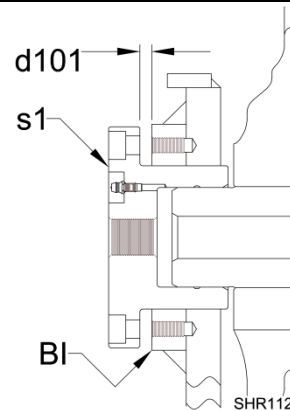
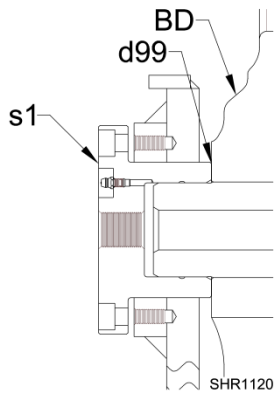

7. Add shims (s3) between the flange "A" (s1) rim and the frame. Shim thickness total should be the measured clearance plus .0275" (0.7mm).

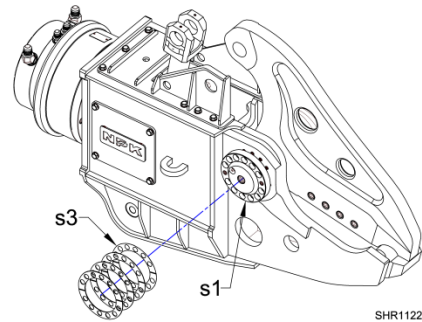

8. Install socket head cap screws (OO) into flange "A" (s1) and tighten. (No torque at this time.)

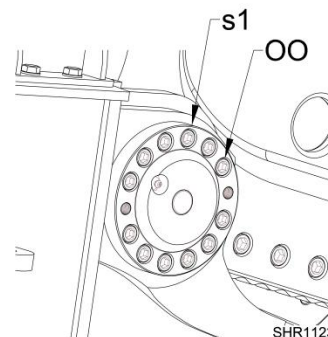

# PIVOT GROUP ADJUSTMENT

## ADJUSTMENT PROCEDURE

9. Hit the arm (BD) with a dead blow hammer (t2) from the flange "B" (s2) side until it is in contact with the thrust surface area (31) of flange "A" (s1). Set the clearance (d99) to 0.

At this time, the clearance between the cutter blades should be  $.0354''$  to  $.0472''$  (0.9 to 1.2mm).

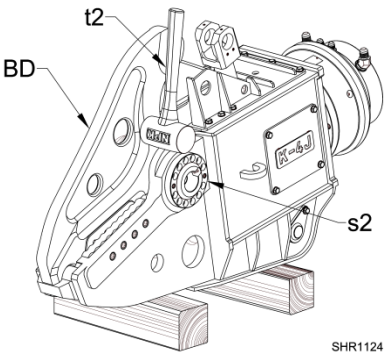

SHR1124

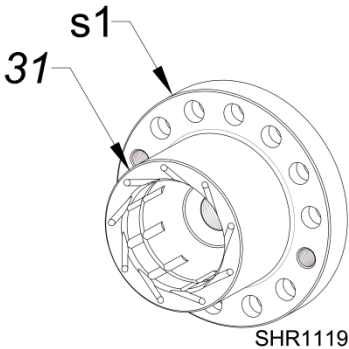

SHR1119

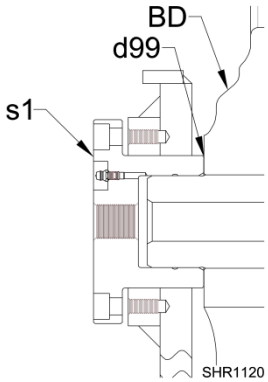

SHR1120

10. Make the flange "B" (s2) thrust surface area (31) contact the arm (BD). Set the clearance (d100) to 0.

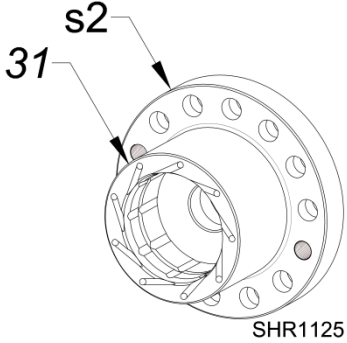

SHR1125

11. Measure the clearance (d102) between the rim of flange "B" (s2) and the frame (BI). Add  $.0118''$  (0.3mm) to the measured clearance.

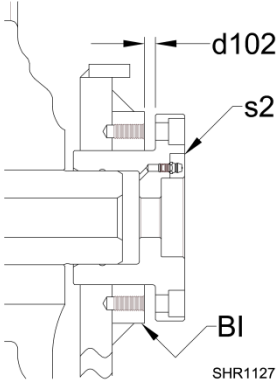

SHR1127

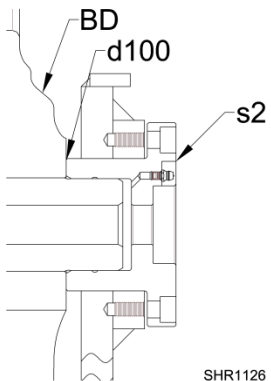

SHR1126

# PIVOT GROUP ADJUSTMENT

## ADJUSTMENT PROCEDURE

12. Add shims (s3) between the flange "B" (s2) rim and the frame. Shim thickness total should be measured clearance plus .0118" (0.3mm).

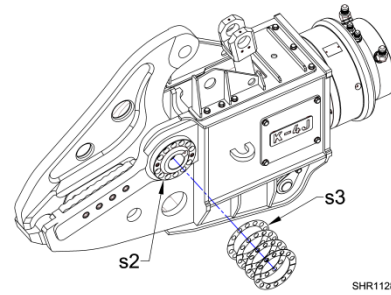

13. Install socket head cap screws (OO) into flange "B" (s2) and tighten. (No torque at this time.)

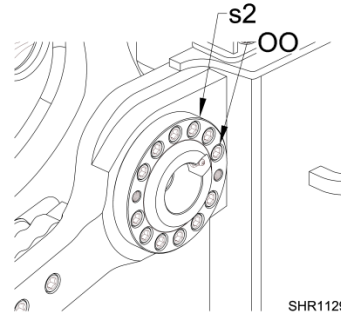

14. Measure the clearances at point's d98, d99, and d100. Make sure they measure the same as the required dimensions as shown in the "PROPER CLEARANCES" section, page 51.

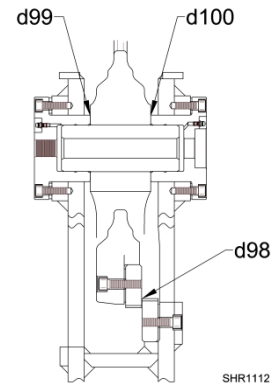

### ATTENTION

Measure the clearances (d99 and d100) using a feeler gauge (t78) between the thrust surface of flanges "A" and "B" (s1 and s2) and the mating arm (BD) surface. *Do not measure the clearance between the frame and the arm.*

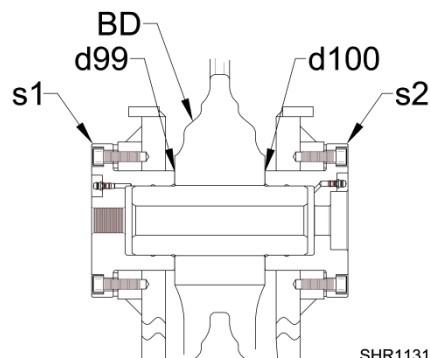
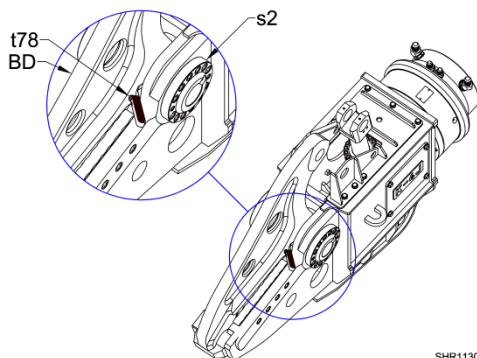

# PIVOT GROUP ADJUSTMENT

## ADJUSTMENT PROCEDURE

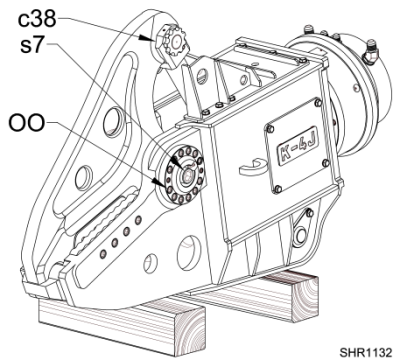
15. Torque cap screws (OO) that secure flange "A" and flange "B".	SHEAR MODEL	SOCKET HEAD CAP SCREW SIZE	TORQUE	
			ft. lbs.	(Nm)
	K3JR	M10	50	(70)
	K4JR	M12	95	(130)
	K7JR	M12	95	(130)
16. Torque main pivot pin cap screw (s7).	SHEAR MODEL	PIVOT PIN CAP SCREW SIZE	TORQUE	
			ft. lbs.	(Nm)
	K3JR	M24	405	(550)
	K4JR	M27	480	(650)
	K7JR	M36	N/A	N/A
17. Reconnect the booster/cylinder (c38). Torque pin nut keeper bolt to 21 ft. lbs. (28 Nm).	 <p>The diagram shows a detailed view of a pivot group assembly. Three callout labels are present: 'c38' points to a hydraulic cylinder/booster, 's7' points to a pin nut keeper bolt, and 'OO' points to a cap screw. The assembly is shown resting on a wooden block.</p>			

# JAW INSPECTION AND MAINTENANCE

---

## WEEKLY INSPECTION

### HARDFACING

Surfaces of the K Series Shear main frame (BI) can be hard faced (we3). The best time to apply or rebuild is as soon as the hard face pattern is worn off or when the shear is new. If the hard face pattern is worn off or when the unit is new, the surfaces should be rebuilt and hard faced such that they are even with or slightly above the adjoining blades.

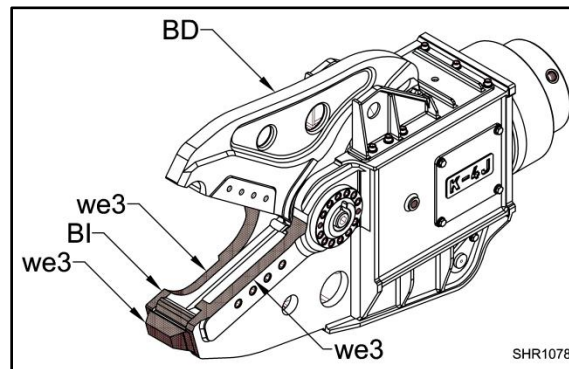

### ATTENTION

**NOTE:** *DO NOT* hard face any surface of the moveable jaw (BD).

## JAW REBUILD PROCEDURE

To ensure maximum performance of the K Series Shear, this rebuild procedure, comprised of three steps, should be followed:

1. Surface Preparation.
2. Underlayment Weld.
3. Hard Face Weld.

### 1. SURFACE PREPARATION

Grind the entire worn area until it is smooth and clean. Remove all paint, grease, oil, dirt, and old hard facing material before welding.

# JAW INSPECTION AND MAINTENANCE

## JAW REBUILD PROCEDURE

### 2. UNDERLAYMENT

Underlayment weld is necessary to build-up the base material (DH) to match the original jaw or tooth profile before hard facing. You cannot hard face over old hard facing.

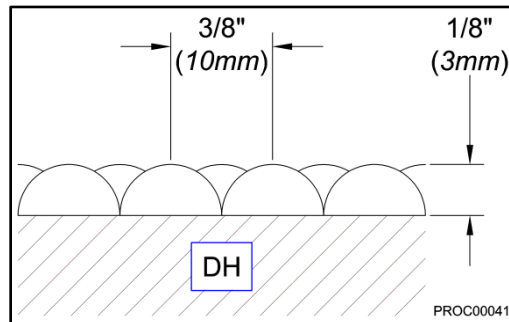

- Welding rod: Airco Austex 361, Cronatron 7770, Eutectic 3205, Postalloy 205, Stoody 2110 or equal. In Canada: NCH Canada Inc. Hi-Pact #194 or equal.
- Dry welding rod at 300°F+ (150°C+).
- Pre-heat the jaw area to 300° - 400°F (150° - 200°C) and maintain this temperature during the welding operation. It is very important to maintain this temperature in cold environments.
- Adjust weld current to rod manufacturer's specifications.
- Peen each layer.
- Cool slowly. Cover weld in cold environments.

### 3. HARD FACE

Hard face (we3) can only be applied over base material (DH) or underlayment weld (we2). **NEVER HARD FACE OVER EXISTING HARD FACE!**

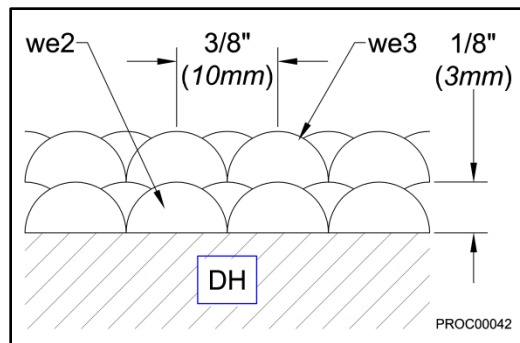



# JAW INSPECTION AND MAINTENANCE

---

## JAW REBUILD PROCEDURE

Welding Rod: Airco Tubecraft 1A, Cronatron 7355, Eutectic N6006, Postalloy 214, Stoodly 31 or equal. In Canada: NCH Canada Inc. Wear-X #176 or equal.

- Dry welding rod at 300°F+ (150°C+).
- Pre-heat the jaw area to 350°F (177°C) and maintain this temperature during the welding operation. It is very important to maintain this temperature in cold environments.
- Adjust weld current to rod manufacturer's specifications.
- Peen each layer. Do not exceed 2 – 3 layers of hard face.
- Cool slowly. Cover weld in cold environments.

### **DO NOT WELD OVER OLD HARD FACING!**

*Remove all old hard facing before applying new underlay weld.*

# FRAME MAINTENANCE – REPAIR OF MAIN FRAME

Inspect frame for cracks periodically. Crushing or shearing is an abusive operation and eventually frame cracking may occur. If the attachment has been overstressed due to improper operation or has been used for many hours of operation, the steel components may develop fatigue cracks. If cracking is found in any of the steel components of the processor, photos of the crack or cracks must be emailed to NPK immediately so that the crack can be evaluated, and a repair option recommended.

## ROUTINE WELD REPAIR

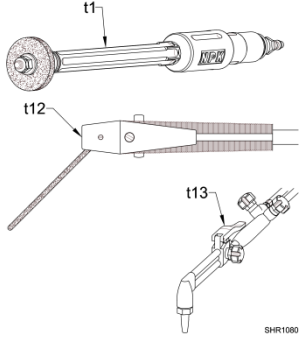
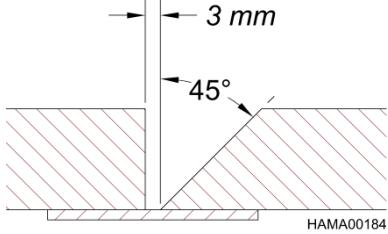
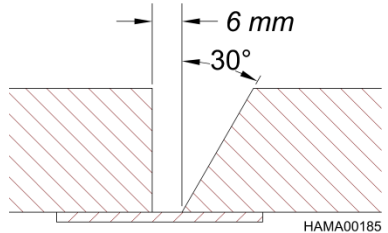
<p>1. Gouge any cracks 100% using an air or electric handheld grinder (t1), carbon arc (t12), or torch (t13).</p>	 <p>The diagram illustrates three methods for gouging a crack: t1 (handheld grinder), t12 (carbon arc gouging), and t13 (torch gouging).</p>
<p>2a. Grind gouged area to a 30° angle on each side to the full depth of the gouged area for plate sizes up to 3/4" (19 mm) thick.</p>	 <p>The diagram shows a cross-section of a 3 mm wide gouge with a 30-degree bevel on each side. The plate thickness is indicated as up to 19 mm.</p>
<p>2b. Grind gouged area to a 45° angle on each side to the full depth of the gouged area for plate sizes over 3/4" (19 mm) thick.</p>	 <p>The diagram shows a cross-section of a 6 mm wide gouge with a 45-degree bevel on each side. The plate thickness is indicated as over 19 mm.</p>
<p>3. If the crack is completely through the plate, grind the bevel in halfway from both sides. Remove all slag and grinding residue.</p>	
<p>4. Consult the <b>JAW and TOOTH REBUILD PROCEDURE, HARD FACE</b> section for pre-heat and welding instructions.</p>	

# FRAME MAINTENANCE – REPAIR OF MAIN FRAME

## ROUTINE WELD REPAIR

5. Peen or stress relieve after each pass. Maintain pre-heat.

6. After welding, grind area flush.

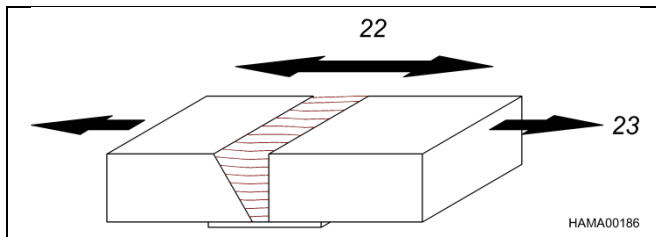

22	DIRECTION OF GRINDING
23	DIRECTION OF PRINCIPLE STRESS

7. Allow area to cool slowly (eight hours minimum). Cover with a heat blanket or other suitable insulation. **FAILURE TO DO SO MAY CAUSE CRYSTALLIZATION OF THE WELD AND SUBSEQUENT BREAKAGE.**

**NOTE:** *NPK Construction Equipment has developed this repair procedure based on known information about structure and material. This, however, does not imply that repairs made using this procedure are guaranteed to be successful. NPK, therefore, cannot warranty this procedure. There is **NO** warranty regarding this repair either expressed or implied.*

# INSPECTION AND MAINTENANCE

## BOOSTER/CYLINDER DISASSEMBLY AND INSPECTION CYLINDER COMPONENT DISASSEMBLY

1. Remove the fifteen-cylinder end cap (c5) socket head cap screws (OO) from the cylinder housing (c4).

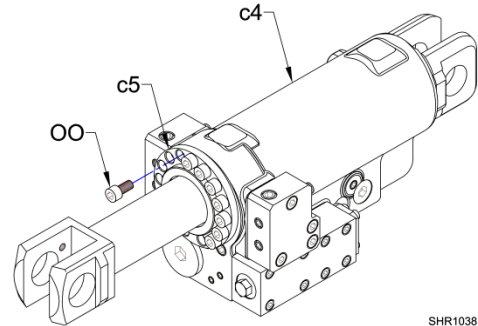

2. Remove the cylinder rod assembly (c48) from the booster/cylinder housing (c4).

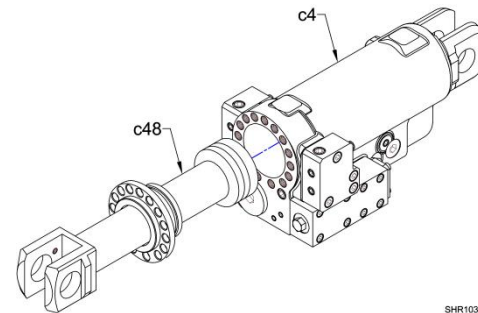

3. Remove cylinder packing (c50) from the piston (c2).

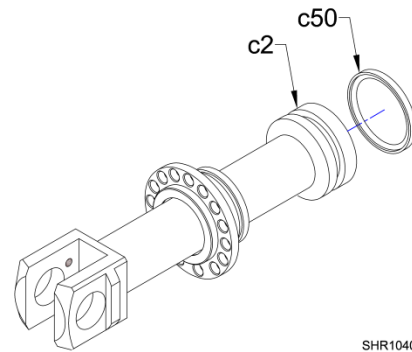

4. Lightly heat the rod nut set screw (c6) to loosen any thread adhesive that is present. Remove the set screw.

**⚠ WARNING**

**DO NOT OVERHEAT SET SCREW!**

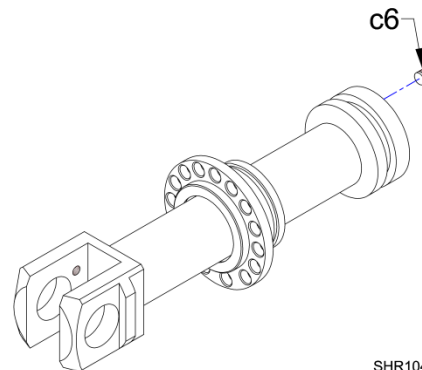

# INSPECTION AND MAINTENANCE

## BOOSTER/CYLINDER DISASSEMBLY AND INSPECTION CYLINDER COMPONENT DISASSEMBLY

5. Unscrew the piston (c2) and remove from the cylinder rod (c3). Then remove the cylinder end cap (c5).

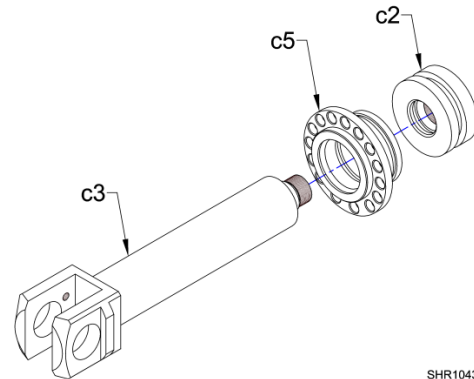

6. Remove the dirt seal (QQ), the rod seal (PP), the o-ring (RR) and backup ring (SS) from the cylinder end cap (c5) and discard.

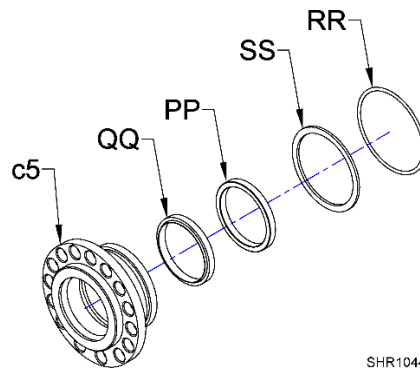

7. Remove the o-ring (RR) and backup ring (SS) from the piston (c2) and discard.

**NOTE:** The cylinder rod is a forged, high strength part. It is not possible to repair the rod. If the rod is bent or damaged, it must be replaced.

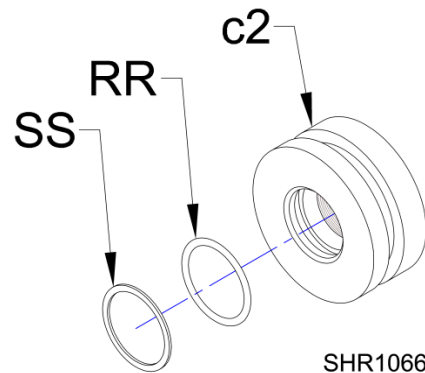

8. Using a straight edge (t15), check the cylinder rod (c3) for straightness.

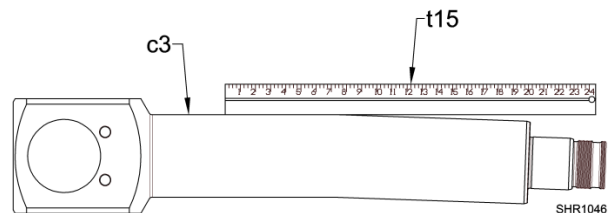

# INSPECTION AND MAINTENANCE

## BOOSTER/CYLINDER DISASSEMBLY AND INSPECTION CYLINDER COMPONENT DISASSEMBLY

9. Remove the two plugs shown (bs44) and (bs46) from the booster/cylinder housing (c4) and discard the o-rings (RR).

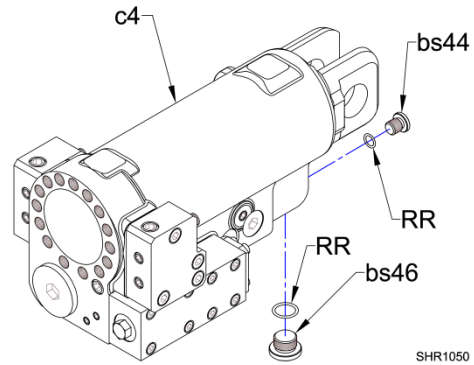

# INSPECTION AND MAINTENANCE

## BOOSTER/CYLINDER DISASSEMBLY AND INSPECTION

### BOOSTER COMPONENT DISASSEMBLY

1. Remove the eight hex head cap screws (OO) securing the main control valve block (c15) to the booster/cylinder housing (c4). Then remove the main control valve block.

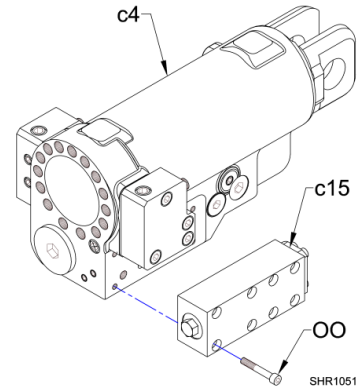

2. Remove and discard the seven o-rings (RR) from the counter bores on the machined mating surface of the block (c15).

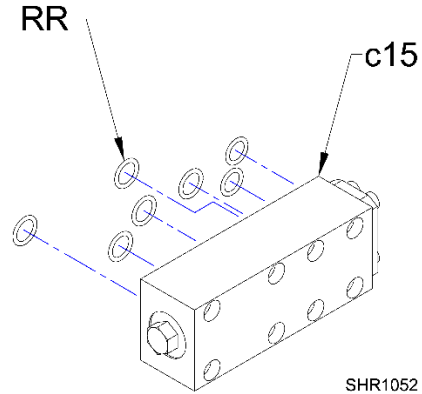

3. Disassemble the control valve block.
  - a. Remove the four hex head cap screws (OO) securing the control valve cap (bs5) to the control valve block body (bs10).

**NOTE:** Exercise care when removing the control valve cap. While removing the cap screws, push downward on the control valve cap, against the force of the spring, then allow the spring to slowly raise the cap.

- b. Remove the cap (bs5) and discard the o-rings.

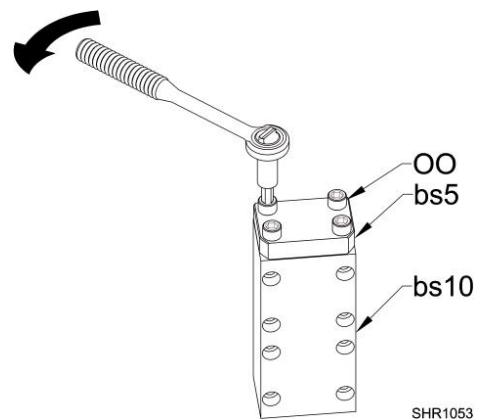

# INSPECTION AND MAINTENANCE

## BOOSTER/CYLINDER DISASSEMBLY AND INSPECTION

### BOOSTER COMPONENT DISASSEMBLY

- c. Remove the plunger (c19) from the cap and inspect.
- d. Remove the main valve spool (bs2) and inspect.
- e. Remove the spring (bs6).
- f. Remove the plug (pta) and discard the o-ring.

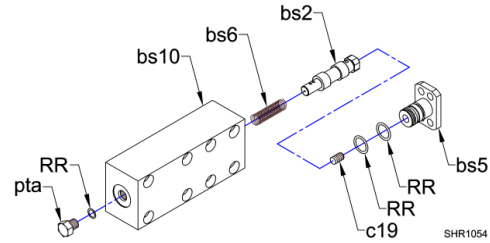

4. Remove the four hex head cap screws (OO) securing the inlet block (bs22) to the booster/cylinder housing (c4).

5. Remove and discard the o-ring (RR) from the counter bore on the machined mating surface of the block.

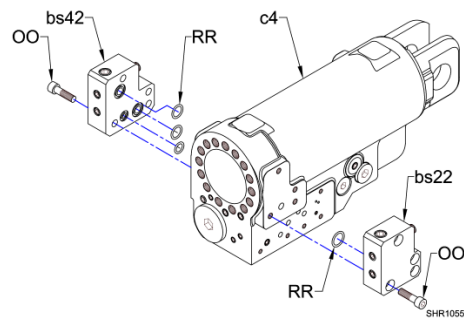

6. Remove the four hex head cap screws (OO) securing the return block (bs42) to the booster/cylinder housing (c4).
7. Remove and discard the three o-rings (RR) from the counter bores on the machined mating surface of the block.
8. Remove the plug (bs48) holding the pilot check valve poppet (c20) and spring (bs26) in place. Discard the o-ring (RR).
9. Remove the spring and check valve poppet. Inspect the seat area of the poppet.

10. Visually inspect the pilot check valve seat (bs15). Remove the seat if there is damage.

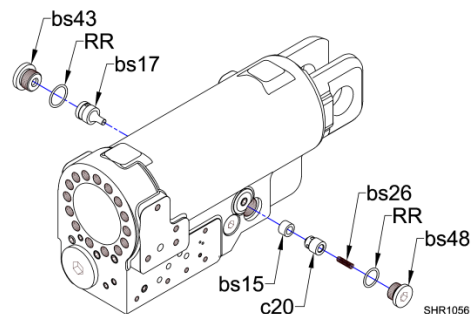



# INSPECTION AND MAINTENANCE

## BOOSTER/CYLINDER DISASSEMBLY AND INSPECTION

### BOOSTER COMPONENT DISASSEMBLY

11. Remove the plug (bs43) holding the plunger (bs17) in place. Inspect the plunger for damage. Discard the o-ring (RR).
12. Remove the (long) plug (bs47) holding the check valve poppet (c24) and spring (bs26) in place. Discard the o-ring (RR).
13. Remove the spring and check valve poppet. Inspect the seat area of the poppet.

14. Visually inspect the check valve seat (bs15). Remove the seat if there is damage.

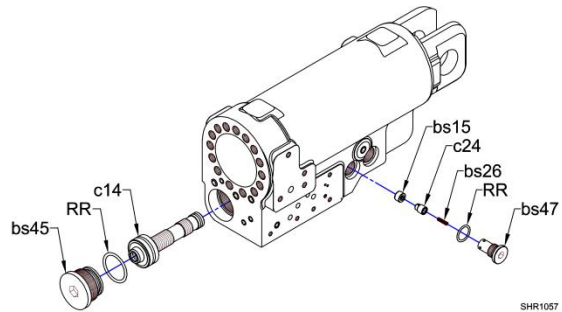

15. Remove the large plug (bs45) below the cylinder bore and discard the o-ring. Remove the booster piston (c14).

16. Disassemble the booster piston.
  - a. Break and remove both seals (bs29) by placing a screwdriver blade (t22) against the seal, then striking the screwdriver handle with a hammer.
  - b. Using a narrow jaw vise (t48), secure the piston (c14) between two wood blocks (t20), vertically, at the narrowest diameter of the piston.
  - c. Using a propane torch, heat the small diameter end of the piston sufficiently to soften the thread sealant used to secure the plug.

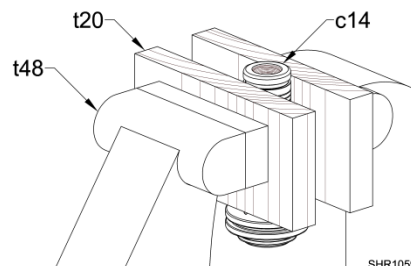
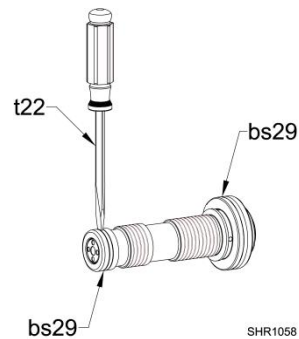

# INSPECTION AND MAINTENANCE

## BOOSTER/CYLINDER DISASSEMBLY AND INSPECTION

### BOOSTER COMPONENT DISASSEMBLY

#### **⚠ WARNING**

*Heated parts can cause severe burns! Wear thermal-protective gloves when handling heated parts. Warn other people within the work area as to the use of heat and the presence of heated parts!*

#### **⚠ CAUTION**

*Do not apply excessive heat to the end of the piston! Apply only sufficient heat required to soften the thread sealant used to secure the plug. Once cool, bluing of the end of the piston indicates over-heating, which may have permanently damaged the piston.*

- d. Remove the plug from the piston (c14) using a hex key wrench (t25), see CAUTION note above.
- e. Remove the spring (bs26) and the check valve poppet (c22). Inspect the seat area of the poppet.

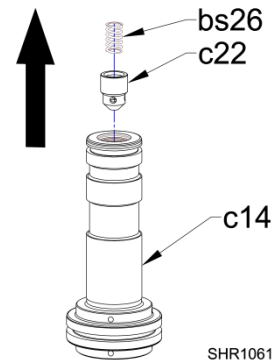
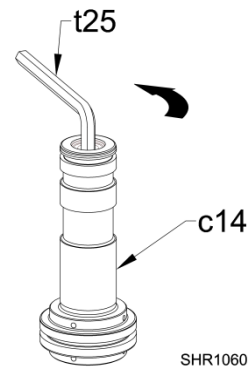

# INSPECTION AND MAINTENANCE

---

## INSPECTING AND CLEANING BOOSTER/CYLINDER COMPONENTS

### CAUTION

The prevention of foreign contaminant damage is critical when working with hydraulic equipment. Keep the work area clean. Using masking tape, cover all exposed holes and parts which may allow entry of foreign contaminants. Habitually clean the work area by wiping with a lint-free dry cloth.

Mating surfaces are machined to a smooth surface. Use care to avoid scratches, nicks, dents, or other damage to machined surfaces. If damaged, the component must be repaired or replaced as required.

1. Clean all parts with a degreaser solvent using a Scotchbrite® or equivalent cleaning pad.

### WARNING

*Compressed air can cause injury or death! Limit air pressure to a maximum of 30 psi (2 bar). Protect your eyes with safety glasses! Do not direct compressed air current at exposed skin! Do not direct compressed air current at other people within the work area!*

2. Remove all thread sealant from threads using an appropriate thread sealant solvent. Remove old thread sealant residue with a maximum of 30 psi (2 bar) of compressed air.
3. Inspect the heads and threads of all fasteners and plugs and corresponding threaded bores for damage. Repair or replace as required
4. Ensure free movement of all poppets, plungers, and spools within their corresponding bores. Inspect all poppets, plungers, spools, seats, and corresponding bores for evidence of damage, wear, or deformity. Particularly close attention should be given to conical ends and corresponding seats. Inspect for annular rings caused by striking against the seat with excessive force. Replace if damaged, worn, or otherwise deformed. Do not attempt to repair!
5. Inspect all components, particularly machined surfaces, including all hydraulic ports, for evidence of scratches, scoring, nicks, dents, wear, deformity, or other damage. Particularly close attention should be given to o-ring grooves and counter bores. Repair or replace as required.
6. Inspect drained and residual hydraulic fluid for evidence of contamination. If contaminated, inspect all components, seals, etc., to determine the cause.

# INSPECTION AND MAINTENANCE

## BOOSTER/CYLINDER ASSEMBLY

### INSPECTING AND CLEANING BOOSTER/CYLINDER COMPONENTS

7. When removed from the control valve block, inspect the main spool and bore for scuffing or cavitation. The spool should move smoothly within the bore of the block. If worn or damaged, repair or replace the affected component as required. Light scratches may be polished to a smooth surface. Heavy scoring is not repairable, and therefore, component replacement is required.

8. When removed from the booster/cylinder housing, inspect the booster piston and bore for scuffing or cavitation. The booster piston should move smoothly within its bore. If worn or damaged, repair or replace the affected component as required. Light scratches may be polished to a smooth surface. Heavy scoring is not repairable, and therefore, component replacement is required.

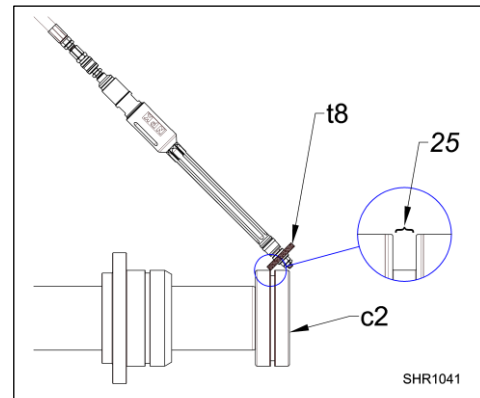

9. Using NPK's gray polishing stone (t8), polish the leading edges of the packing groove (25) to remove damage to the piston (c2) and prevent damage to the packing.

10. Inspect the cylinder bore (c4). Lightly hone using a ball hone (t17). If there is heavy scoring, booster/cylinder housing replacement will be required.

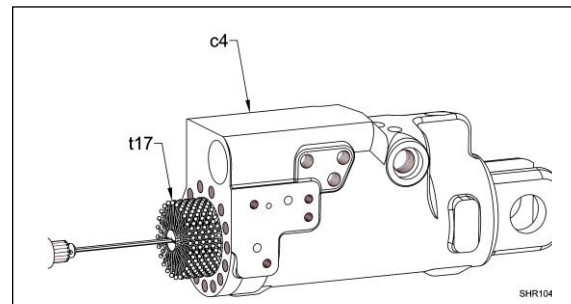

11. Inspect the check valve poppet and seat located in the small diameter end of the booster piston. Replace the check valve poppet or booster piston if they are chipped or scored.

**NOTE:** *The seat for the check valve poppet is part of the booster piston; therefore, if it is chipped or damaged, the booster piston will need to be replaced.*

12. Inspect the check valve poppet and seat located in the booster/cylinder housing (*under the long plug*). Replace these components if they are chipped or scored.

13. Inspect the pilot check valve poppet, seat and plunger located in the booster/cylinder housing. Replace these components if they are chipped or scored.

# INSPECTION AND MAINTENANCE

## BOOSTER/CYLINDER ASSEMBLY

### BOOSTER COMPONENT ASSEMBLY

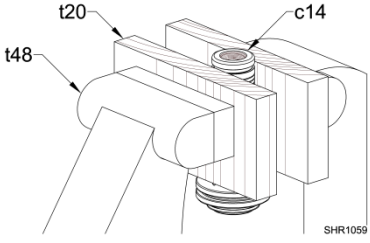
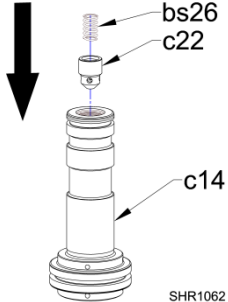
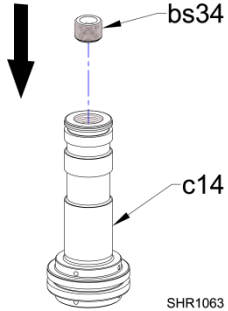
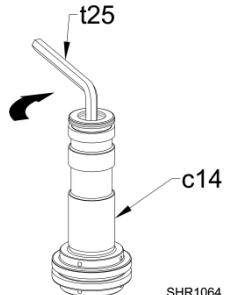
<p>1. Assemble booster piston.</p> <p>a. Using a narrow jaw vise (t48), secure the booster piston (c14) between two blocks of wood (t20) at the narrowest diameter, vertically in the vise.</p>	
<p>b. Install the poppet (c22) and spring (bs26) into the booster piston (c14).</p>	
<p>c. Lightly apply high-strength thread sealant to the clean dry threads of the plug (bs34) then install it into the threaded bore of the booster piston.</p> <p><b>NOTE:</b> Sealant sets up in about 10 minutes, cures after about 24 hours.</p>	
<p>d. Secure the plug into the booster piston (c14) using a hex key wrench (t25).</p>	
<p>e. Remove the piston from the vise.</p> <p><b>⚠ WARNING</b></p> <p><i>Boiling water can cause severe burns! Do not place fingers or hands into the boiling water! Use an appropriate tool to remove the seals from boiling water!</i></p>	

# INSPECTION AND MAINTENANCE

## BOOSTER/CYLINDER ASSEMBLY

### BOOSTER COMPONENT ASSEMBLY

- f. Immerse two new seals into a container of boiling water for several minutes. When pliable, use an appropriate tool to remove the seals from the boiling water.

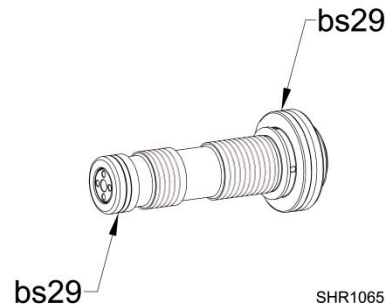

- g. Stretch the seals (bs29) over the booster piston and into place in the corresponding piston grooves. Apply a light coat of hydraulic oil or NPK Assembly Lubricant to the outside surface of the booster piston.

2. Install the booster piston (c14) into the cavity below the cylinder bore. Install a new o-ring (RR) onto the plug (bs45). Apply a light coat of hydraulic oil or NPK Assembly Lubricant to the o-ring (RR). Install the plug into the booster/cylinder housing. Torque plug to 220 ft. lbs. (300 Nm).

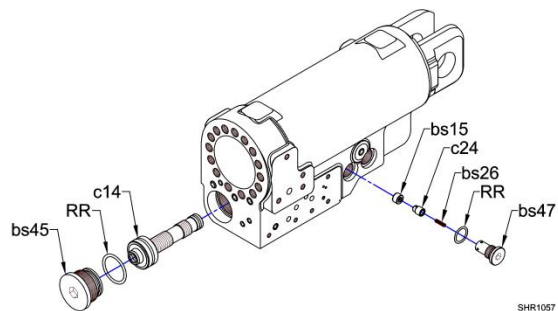

3. Install a new seat (bs15) into the check valve cavity of the booster/cylinder housing (if required). Install check valve poppet (c24) and spring (bs26). Install a new o-ring (RR) onto the (long) plug (bs47). Apply a light coat of hydraulic oil or NPK Assembly Lubricant to the o-ring. Install the plug into the housing. Torque plug to 118 ft. lbs. (160 Nm).

4. Install a new seat (bs15) into the pilot check valve cavity of the booster/cylinder housing (if required). Install the pilot check valve poppet (c20) and spring (bs26). Install a new o-ring onto the plug (bs48). Apply a light coat of hydraulic oil or NPK Assembly Lubricant to the o-ring. Install the plug into the housing. Torque plug to 132 ft. lbs. (180 Nm).

# INSPECTION AND MAINTENANCE

## BOOSTER/CYLINDER ASSEMBLY

### BOOSTER COMPONENT ASSEMBLY

<p>5. Apply hydraulic oil or NPK Assembly Lubricant to the outside surface of the plunger (bs17). Install the plunger into the booster/cylinder housing. Install a new o-ring onto the plug (bs43). Apply a light coat of hydraulic oil or NPK Assembly Lubricant to the o-ring. Install the plug into the housing. Torque plug to 118 ft. lbs. (160 Nm).</p>	
<p>6. Apply high strength thread sealant (t41) to the clean dry threads of the eight previously removed socket head cap screws (OO).</p>	
<p>7. Install new o-rings (RR) into the three counter bores of the return block (bs42). Apply a thin coat of grease on the o-rings. Install the block and four socket head cap screws (OO) onto the booster/cylinder housing (c4). Torque the socket head cap screws to 52 ft. lbs. (70 Nm).</p>	
<p>8. Install a new o-ring (RR) into the counter bore provided on the inlet block (bs22). Apply a thin coat of grease on the o-ring. Install the block and four socket head cap screws (OO) onto the booster/cylinder housing. Torque the socket head cap screws to 52 ft. lbs. (70 Nm).</p>	
<p>9. Assemble the main control valve block.</p>	

# INSPECTION AND MAINTENANCE

## BOOSTER/CYLINDER ASSEMBLY

### BOOSTER COMPONENT ASSEMBLY

- a. Install a new o-ring onto the plug (pta). Apply a light coat of hydraulic oil or NPK Assembly Lubricant to the o-ring. Install the plug into the main valve housing (bs10). Torque the plug to 21 ft. lbs. (28 Nm).
- b. Apply hydraulic oil or NPK Assembly Lubricant to the inner bore of the main valve housing, the inner bore of the control valve cap (bs5) and to the outside surfaces of the main valve spool (bs2) and the plunger (c19).
- c. Install the spring (bs6) onto the main valve spool. Install the spring (bs6) and the main valve spool into the main valve housing. Install two o-rings (RR) onto the control valve cap. Apply a light coat of hydraulic oil or NPK Assembly Lubricant on the o-rings. Lubricate and install the plunger into the end cap. Installation Note: Make sure the rounded end of the plunger faces the main valve spool (bs2) and the flat end faces the end cap (bs5).

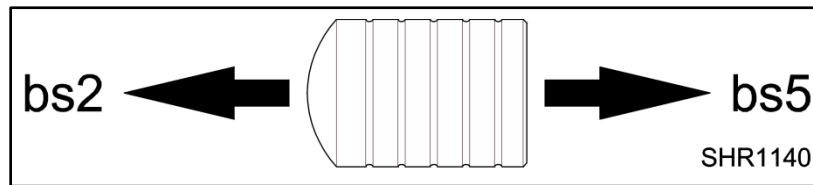

- d. Apply high strength thread sealant (t41) to the clean, dry threads of the four previously removed socket head cap screws (OO).

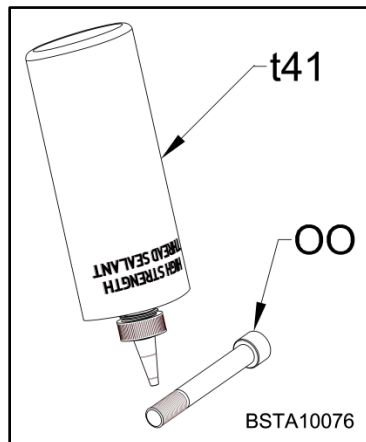



# INSPECTION AND MAINTENANCE

## BOOSTER/CYLINDER ASSEMBLY

### BOOSTER COMPONENT ASSEMBLY

- e. Ensuring proper alignment, carefully press and hold the cap with plunger, squarely onto the spool previously installed.
- f. Secure the cap to the main valve housing using the four socket head cap screws. Tighten the cap screws gradually in an opposing pattern, applying 26 ft. lbs. (35 Nm) torque.

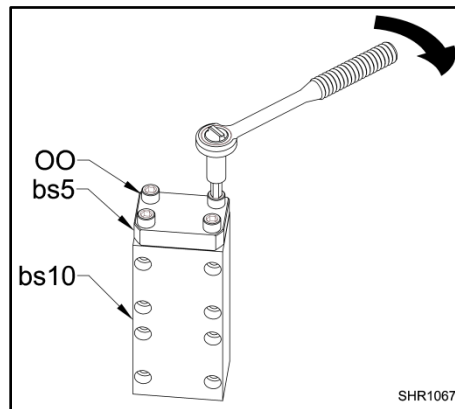

10. Install the seven o-rings into the counter bores on the machined mating surface of the main control valve (c15). Apply a thin coat of grease to the o-rings.

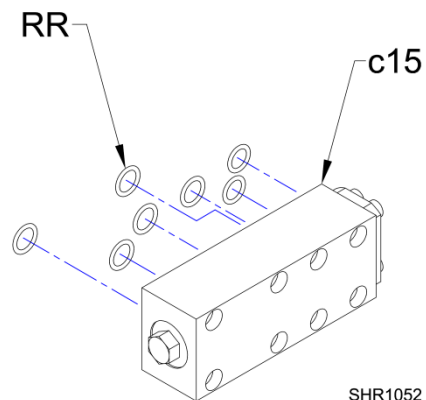

11. Apply high-strength thread sealant (t41) to the clean dry threads of the eight previously removed socket head cap screws (OO).

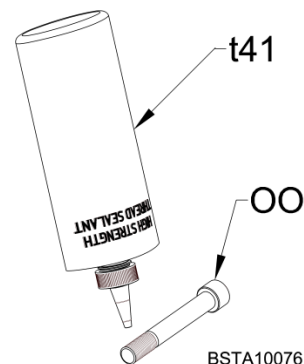

# INSPECTION AND MAINTENANCE

## BOOSTER/CYLINDER ASSEMBLY

### BOOSTER COMPONENT ASSEMBLY

12. Install the main control valve (c15) and eight socket head cap screws (OO) onto the booster/cylinder housing (c4). Torque the socket head cap screws to 26 ft. lbs. (35 Nm).

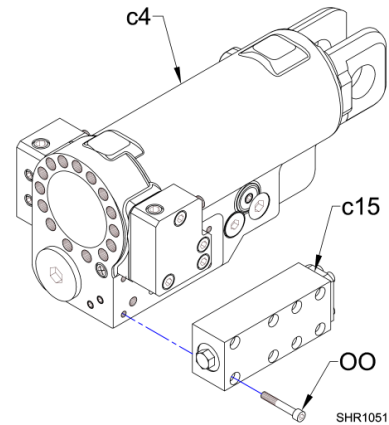

### CYLINDER COMPONENT ASSEMBLY

1. Install dirt seal (QQ) and piston seal (PP) into the seal grooves on the inner side of the cylinder end cap (c5). Install the o-ring (RR) and backup ring (SS) into the outer groove.

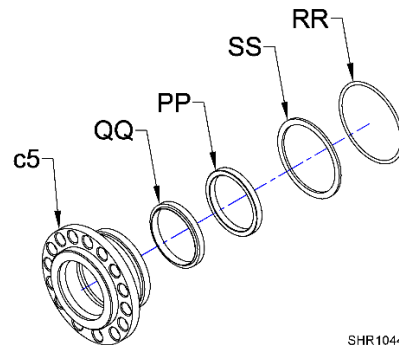

2. Thread the piston (c2) onto the cylinder rod (c3) with the spanner wrench holes (173) facing away from the rod eye (c56). Secure the piston to the cylinder rod using a spanner wrench or equal. (**DO NOT** use thread sealant at this time.)

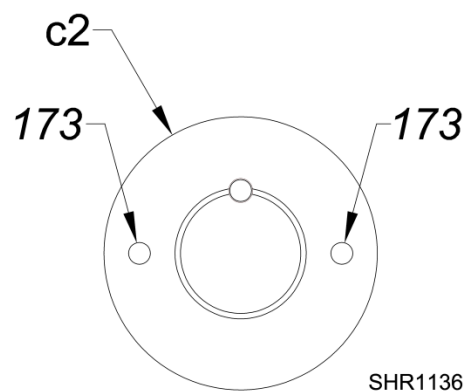
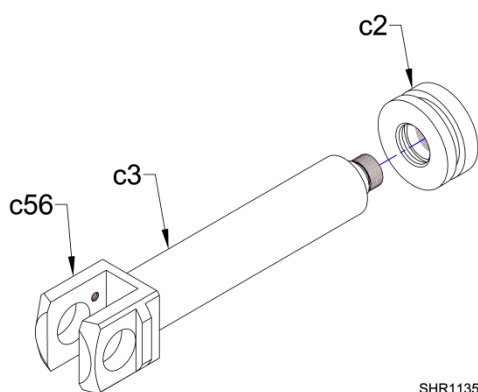

# INSPECTION AND MAINTENANCE

## BOOSTER/CYLINDER ASSEMBLY

### CYLINDER COMPONENT ASSEMBLY

3. Drill and tap a hole (75) between the cylinder rod (c3) and the piston (c2) to accept M10-1.5 thread 3/8" (10 mm) deep.

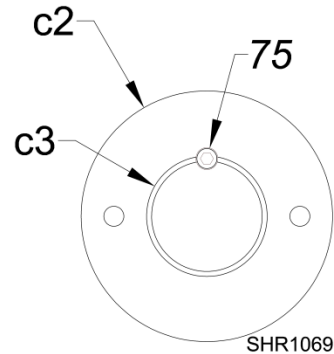

4. Remove the piston from the cylinder rod and clean both parts thoroughly.

5. Apply hydraulic oil or NPK Assembly Lube to the inner surface of the cylinder end cap (c5) coating the previously installed dirt seal and piston seal. Install the cylinder end cap onto the cylinder rod (c3).

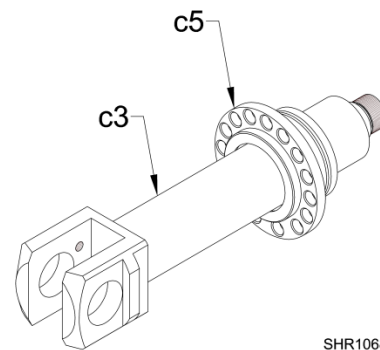

6. Install the o-ring (RR) and backup ring (SS) into the piston (c2). Apply a light coat of hydraulic oil or NPK Assembly Lubricant to the o-ring and backup ring after installation.

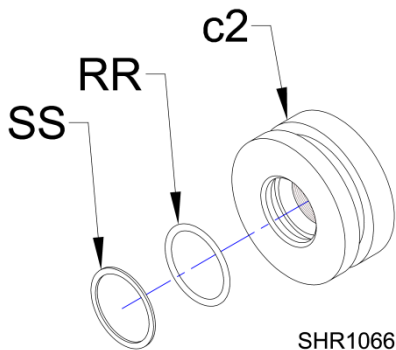

# INSPECTION AND MAINTENANCE

## BOOSTER/CYLINDER ASSEMBLY

### CYLINDER COMPONENT ASSEMBLY

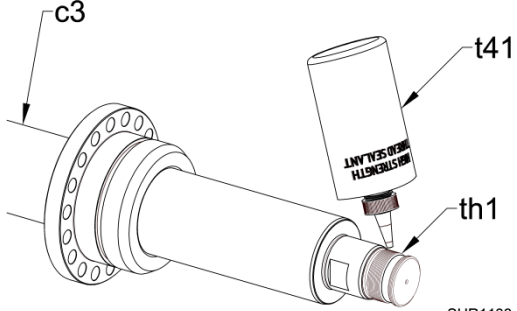
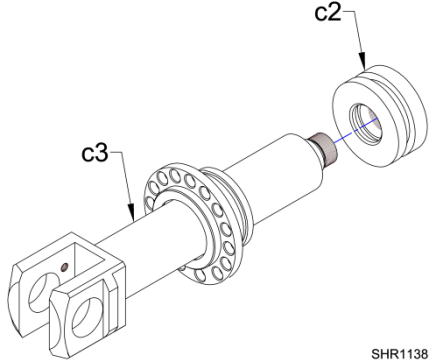
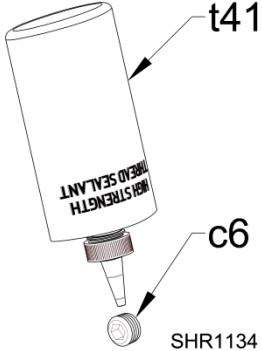
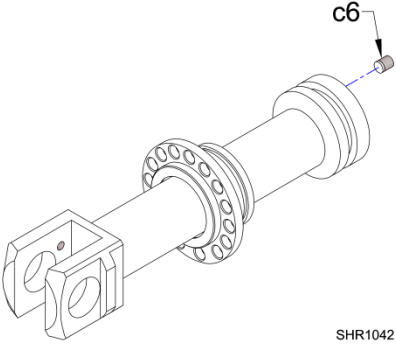
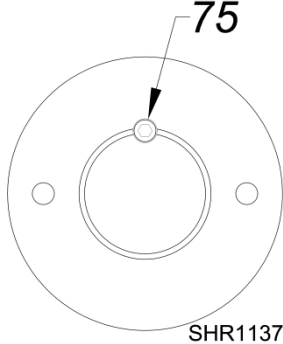
<p>7. Apply high strength thread sealant (t41) to the clean dry threads (th1) of the cylinder rod (c3).</p>	 <p>SHR1133</p>	
<p>8. Thread the piston onto the cylinder rod with the spanner wrench holes facing away from the rod eye. Secure the piston to the cylinder rod using a spanner wrench or equal.</p>	 <p>SHR1138</p>	
<p>9. Apply a small amount of thread adhesive (t41) to the flat point socket set screw (c6). Thread the set screw into the previously drilled and tapped hole (75). Torque to 10 ft. lbs. (14 Nm).</p>		
 <p>SHR1134</p>	 <p>SHR1042</p>	 <p>SHR1137</p>

# INSPECTION AND MAINTENANCE

## BOOSTER/CYLINDER ASSEMBLY

### CYLINDER COMPONENT ASSEMBLY

10. Install packing (c50) onto the cylinder piston (c2).

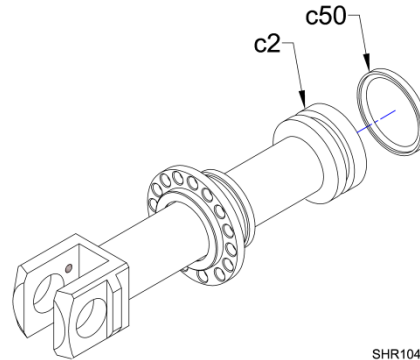

11. Apply hydraulic oil or NPK Assembly Lubricant to the outside surface of the piston/rod assembly (c48) and the inside bore of the booster/cylinder housing (c4). Slowly install the cylinder rod assembly into the booster/cylinder housing.

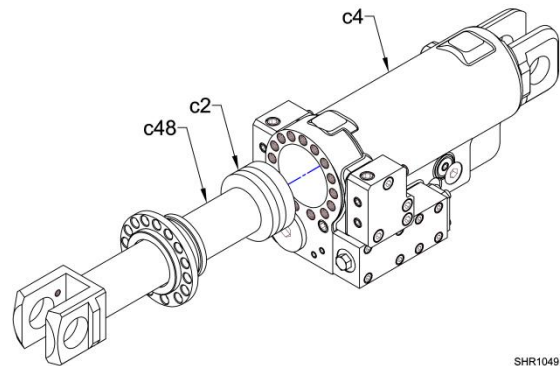

12. Install the fifteen socket head cap screws (OO) through the cylinder end cap (c5) into the booster/cylinder housing (c4). Before installation, lube the threads with grease or anti-seize compound. Torque to 145 ft. lbs. (200 Nm).

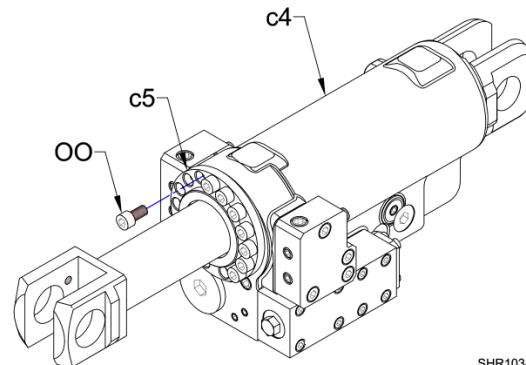

# INSPECTION AND MAINTENANCE

## ROTATOR HEAD

The rotator head assembly (HN) is located between the top bracket (m7) and the shear frame (BI) that rotates. Hydraulic oil for both the open and close operations pass through it.

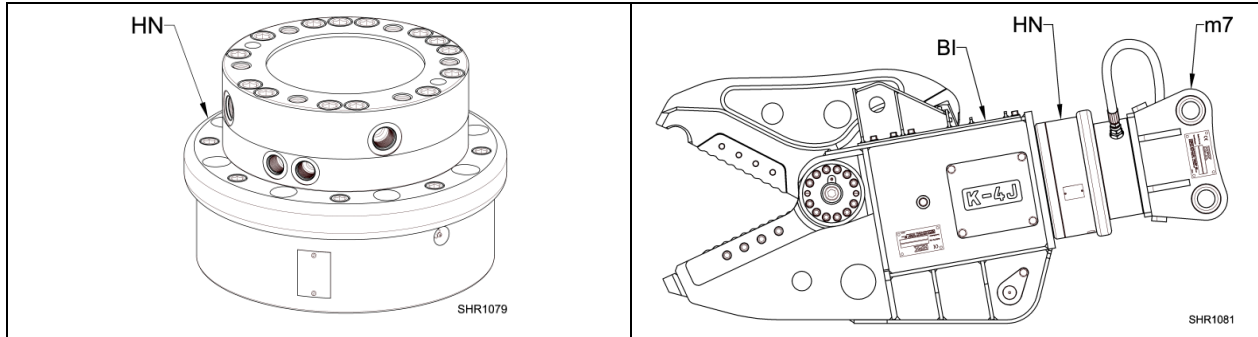

## LEAKAGE OF THE SEALS

External or internal (bypass) leakage of hydraulic oil will require the replacement of the seals in the rotator head. For external leakage, contact the NPK Service Department at 440-232-7900 for seal replacement instructions.

If internal leakage is suspected, please proceed to the “**TESTING THE ROTATOR HEAD SEALS FOR INTERNAL LEAKAGE**” section.

## TESTING THE ROTATOR HEAD SEALS FOR INTERNAL LEAKAGE

If internal leakage is suspected, before disassembling the rotator head, the relief valve pressure setting should be checked. Internal leakage will most likely prevent the unit from reaching the relief setting in the close function. *(There is no relief valve for the open function.)* The relief valve (c17) is mounted in the manifold block (c35) mounted just below the rotator head inside the shear’s main frame (see view below). Access to the relief is through the cover plates (EC) of the shear’s main frame (BI). **NOTE:** *Before attempting to adjust the relief valve setting, check that the relief valve cartridge has not loosened in the manifold.*

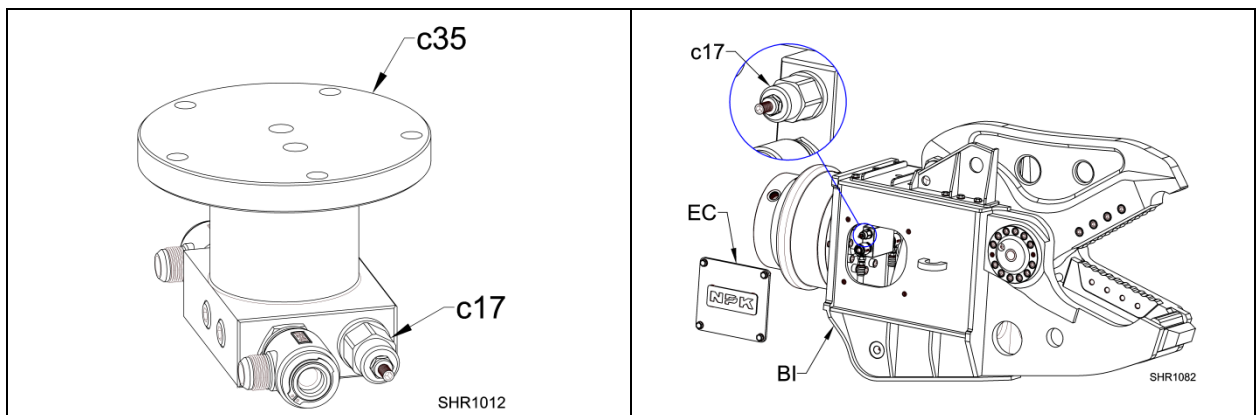

# INSPECTION AND MAINTENANCE

## ROTATOR HEAD

### PROCEDURE

Install a 0-3000 psi (0-250 bar) gauge in the NPK shut-off valve (k4) located on the stick of the carrier. NPK provides a gauge port (k8) to install the gauge. Make sure the shut-off valve is in the "ON" (k5) position during testing.

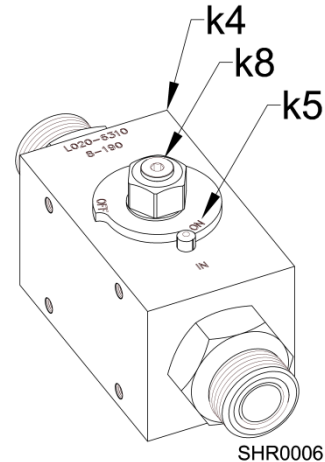

Close the jaw and keep the function activated and read the pressure. Compare the pressure reached with the operating pressure specifications for the K Series Shear. Please note that if the relief pressure cannot be reached with the jaw closed and the intensifier booster is clicking rapidly, this indicates a booster problem and not a relief problem. If the proper relief pressure cannot be reached and the booster slows or stops working, disassemble the rotator head and check for seal or component failure.



The jaw of the shear should be closed, and the frame supported or pinned to prevent rotation during repair. Turn the shut-off valves (k4) on the stick to the "OFF" (k6) position and make sure gauge (k8) port is plugged to prevent excess oil loss.

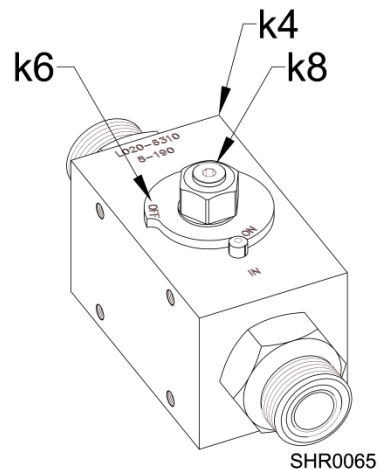

# HOSE TORQUE SPECIFICATIONS

---

## JIC ENDS

NOMINAL SIZE	FITTING DASH SIZE	THREAD SIZE	NUMBER OF FLATS FROM FINGER TIGHT	TORQUE	
				ft. lb.	(Nm)
1/2"	-8	3/4-16	1	36 - 39	(49 - 53)
3/4"	-12	1-1/16-12	1	79 - 88	(107 - 119)
1"	-16	1-5/16-12	1	108 - 113	(146 - 153)
1-1/4"	-20	1-5/8-12	1	127 - 133	(172 - 180)

## ORFS ENDS

NOMINAL SIZE	FITTING DASH SIZE	THREAD SIZE	NUMBER OF FLATS FROM FINGER TIGHT	TORQUE	
				ft. lb.	(Nm)
1/2"	-8	13/16-16	1.25 - 1.75	32 - 35	(43 - 48)
3/4"	-12	1-3/16-12	1.25 - 1.75	65 - 70	(88 - 95)
1"	-16	1-7/16-12	1.25 - 1.75	92 - 100	(125 - 136)
1-1/4"	-20	1-11/16-12	1.25 - 1.75	125 - 140	(170 - 190)



# TROUBLESHOOTING

---

## DETERMINE THE TYPE OF PROBLEM

Performance problems are classified as “**LOSS OF POWER**” or “**LOSS OF CYCLE SPEED**” (*assuming the problem is not due to misapplication*).

### 1. LOSS OF POWER

NPK Shear jaw cutting forces are determined by the operating pressure setting and NPK pressure intensifier performance.

### 2. LOSS OF CYCLE SPEED

NPK Shear cycle speed is determined by oil flow to the unit. The hydraulic installation circuit for the Shear must be set to provide the correct flow.

## DETERMINE THE CAUSE OF THE PROBLEM

Technical problems are caused by either the NPK Shear or the carrier’s hydraulic system (*hydraulic installation kit for the Shear*). Checking the hydraulic pressure and flow will determine if the problem is in the Shear or the carrier. If the pressure and flow to the Shear are correct, the problem is in the Shear.

## LOSS OF POWER

Loss of power can be caused by a low carrier relief valve setting or by a low Shear relief valve setting. Verify the correct relief valve settings of the carrier and the Shear. (See “**SHEAR RELIEF VALVE AND CARRIER RELIEF VALVE SETTINGS**” on page 92.

If the relief valve pressures are to specification, proceed to the “**INTENSIFIER CHECKS**” troubleshooting charts (pages 93 and 94) and the “**PRESSURE INTENSIFIER OPERATION**” section on page 94.

# TROUBLESHOOTING

## TROUBLESHOOTING GUIDE FOR LOW POWER RELIEF VALVE CHECKS

### LOW POWER CHECKS

PROBLEM	CAUSE	CHECK	REMEDY
Operating Pressure is less than 2,610 psi (180 bar).	Carrier hydraulic circuit relief valve.	Measure the carrier circuit relief valve with the pressure to close shut-off valve in the "OFF" position	Adjust or replace the carrier circuit relief valve. The setting for the relief valve must be 500 psi (35 bar), minimum, above the Shear operating pressure.
	Shear relief valves	Measure the relief valves with the shut-off valves on the carrier in the "ON" position. Check pressure with the jaws fully open and fully closed.	Setting should be 2,610 psi (180 bar)
		Check relief cartridges for tightness.	Tighten the relief valve cartridges.
		Check relief cartridges for mis-adjustment.	Reset to 2,610 psi (180 bar). If unable to adjust, replace the cartridge.
		Check the o-rings and backup rings of the relief valve cartridges.	Replace the o-rings and backup rings of both relief valve cartridges.
	Pilot check valve assemblies.	Inspect the booster inlet pilot check valves for damage.	Replace the inlet pilot check valve assemblies if necessary.
	Rotation head	Contact the NPK Service Department at 440-232-7900.	

# TROUBLESHOOTING

---

## TROUBLESHOOTING GUIDE FOR LOW POWER RELIEF VALVE CHECKS

### LOW POWER CHECKS

PROBLEM	CAUSE	CHECK	REMEDY
Operating pressure is at 2,610 psi (180 bar), but the intensifier does not click.	Booster control valve assembly.	Dis-assemble the main valve and inspect the spring, plungers and for free movement of the spool.	Polish or replace as necessary.
	Booster assembly	Dis-assemble the main valve and inspect the piston assembly, seals, poppets and seats.	Polish or replace as necessary.

# TROUBLESHOOTING

## MEASURING OPERATING PRESSURES

### TOOLS AND EQUIPMENT REQUIRED

(For carriers with an NPK hydraulic installation kit installed).

Pressure gauge (g8f): 5,000 psi (350 bar).

Test port adapter (g20): to fit #4 SAE female port in NPK shut-off valve (k4).

Test hose (t81): 5,000 psi (350 bar) rated.

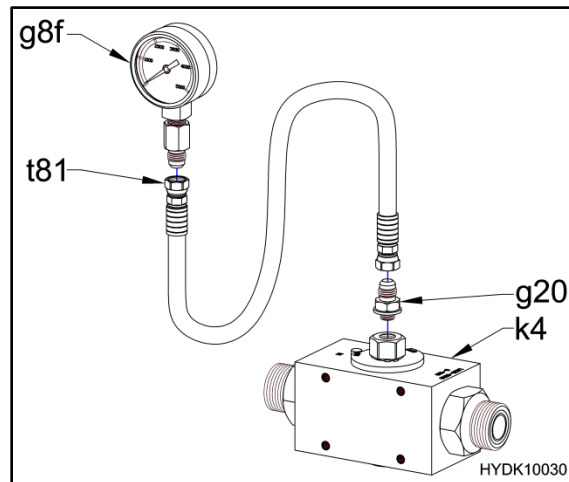

## RELIEF VALVE CHECKING AND SETTING PROCEDURE

Most Hydraulic Installation Kits provide shut-off valves (k4) with test ports (k8) in both the jaw open (m3) and close lines (m4). Install pressure test hoses in both test ports.

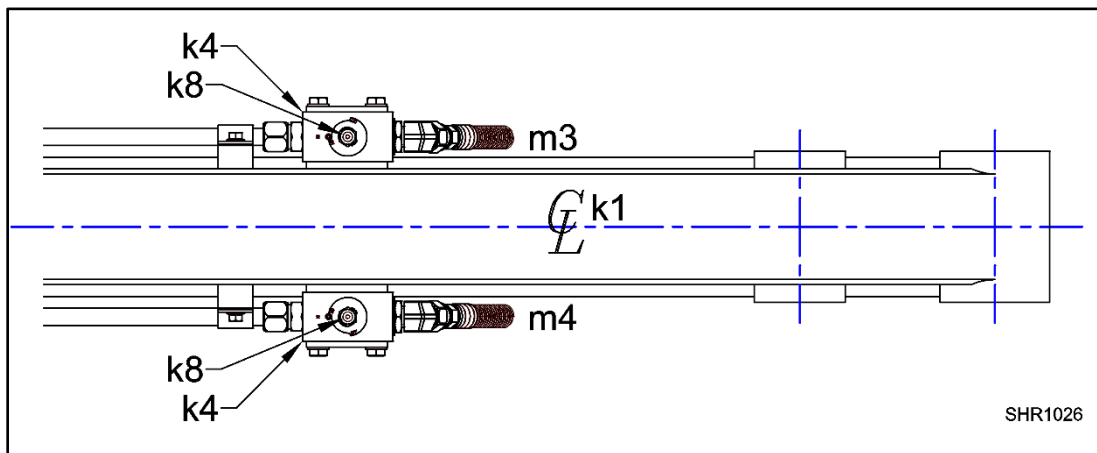

# TROUBLESHOOTING

## RELIEF VALVE CHECKING AND SETTING PROCEDURE

### 1. CARRIER CIRCUIT RELIEF VALVE CHECK

Verify that the hydraulic system of the carrier meets the requirements of the Shear.

- A. Install a 0 – 5,000 psi (350 bar) pressure gauge (g8f) in the #4 SAE test ports in each of the shut-off valves (k4) at the end of the stick.

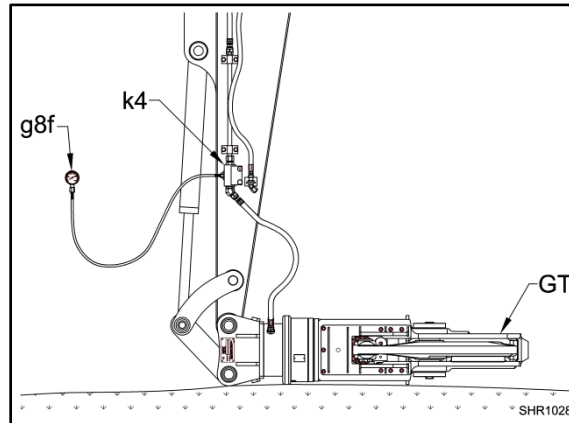

- B. Turn the shut-off valve (k4) in the close circuit to the “OFF” position (k6).

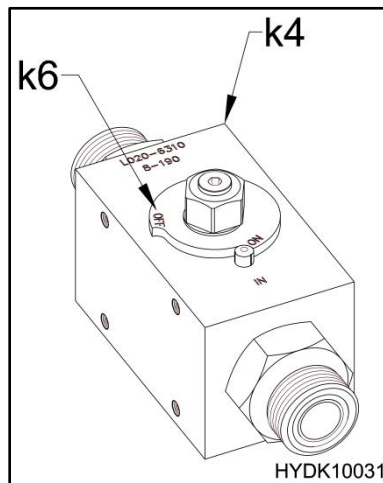

# TROUBLESHOOTING

---

## RELIEF VALVE CHECKING AND SETTING PROCEDURE

- C. Start the carrier. Set the throttle to the "FULL" position. Actuate the hydraulic circuit to close the jaws.

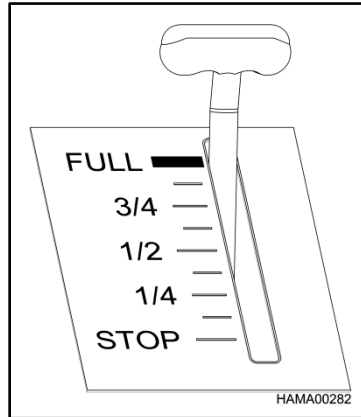

- D. The pressure reading should be at least 500 psi (35 bar) above the Shear operating pressure.

**NOTE:** If the excavator relief setting is less than 500 psi (35 bar) above the Shear operating pressure, reset the excavator accordingly.

# TROUBLESHOOTING

## RELIEF VALVE CHECKING AND SETTING PROCEDURE

### 2. SHEAR RELIEF VALVE

After the Shear hydraulic circuit has been verified, check the Shear relief valve setting for both open and close.

- A. With a 0 – 5000 psi (350 bar) gauge installed in both the open and close side of the stick, open the shut-off valves.
- B. Start the carrier. Set the throttle at full RPM and close the jaws completely and hold for 10 seconds. Check the psi (bar) reading on the gauge and compare to the specified Shear relief valve setting. If it is not the same, reset the Shear relief valve accordingly.
- C. The booster will start to click. Depending on oil temperature, the booster will continue to click slowly compensating internal leaking in the main cylinder. This is normal.
- D. If the intensifier is clicking rapidly, pressure may not reach the relief valve setting due to severe intensifier or cylinder leakage.
- E. Open the Shear jaws to the fully open position and hold for 10 seconds. Check the pressure reading on the gauge and compare to the specified Shear relief valve setting. If it is not the same, reset the Shear relief valve accordingly.

### PRESSURE INTENSIFIER RELIEF VALVE ACTUATION

Close the jaws without material in them. When the Shear's cylinder is fully stroked, the load pressure rises until it reaches the Shear's (GT) relief valve setting (P2). The excavator relief valve acts only as a safety relief and must be set a minimum of 500 psi (35 bar) above the Shear relief valve setting shown below.

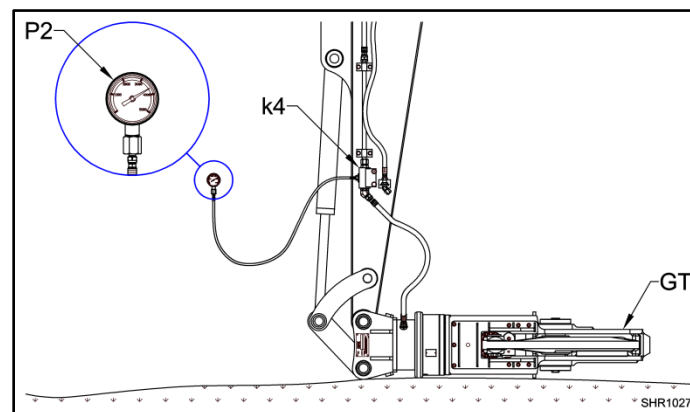

# TROUBLESHOOTING

## SHEAR RELIEF VALVE AND CARRIER RELIEF VALVE SETTINGS

MODEL	SERIAL NO.	P2 SHEAR RELIEF VALVE SETTING		P3 MINIMUM CARRIER RELIEF VALVE SETTING	
		psi	(bar)	psi	(bar)
K3	ALL	2,610	(180)	3,110	(215)
K4	ALL	2,610	(180)	3,110	(215)
K7	ALL	2,610	(180)	3,110	(215)

## RELIEF VALVE LOCATION

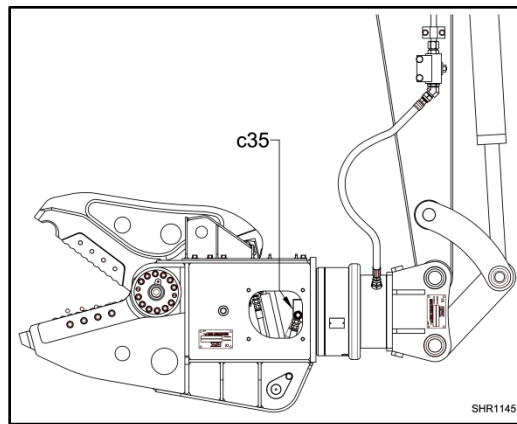

The Shear relief valve cartridge, close (c17) is located in the manifold block (c35) that is bolted to the main frame.

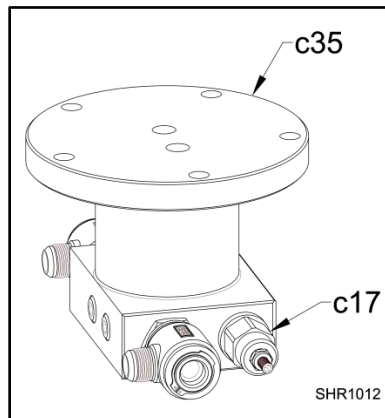



# TROUBLESHOOTING

## INTENSIFIER CHECKS *(unit does not click)*

### INTENSIFIER CHECKS

PROBLEM	CAUSE	CHECK	REMEDY
Intensifier does not click	Shear relief valves	Check relief cartridges for tightness.	Tighten the relief valve cartridges.
		Check relief cartridges for mis-adjustment.	Reset to 2,610 psi (180 bar). If unable to adjust, replace the cartridge.
		Check the o-rings and backup rings of the relief valve cartridges.	Replace the o-rings and backup rings of both relief valve cartridges.
	Booster control valve assembly.	Dis-assemble the main valve and inspect the spring, plungers and for free movement of the spool.	Polish or replace as necessary.
	Booster assembly	Check poppets and seats.	Replace poppets and seats as necessary.
		Check all o-rings and backup rings.	Replace all o-rings and backup rings.

# TROUBLESHOOTING

## INTENSIFIER CHECKS (*unit clicks – does not slow down*)

### INTENSIFIER CHECKS

PROBLEM	CAUSE	CHECK	REMEDY
Intensifier clicks but does not slow down	Shear relief valves	Check relief cartridges for tightness.	Tighten the relief valve cartridges.
	Pilot check valve assemblies.	Inspect the booster inlet pilot check valve assemblies for damaged seats.	Replace the inlet pilot check valve assemblies.
	Booster assembly	Check poppets and seats.	Replace poppets and seats as necessary.
		Check all o-rings and backup rings.	Replace all o-rings and backup rings.
	Main cylinder assemblies	Check main cylinder packing for by-passing oil.	Replace packing.
		Check for damaged seals.	Reseal cylinders

## PRESSURE INTENSIFIER OPERATION

NPK's exclusive pressure intensifier system is used in NPK Shears to boost cylinder pressure to increase the jaw closing forces. When the intensifier is working properly, a rapid clicking sound will be heard, indicating that the pressure intensifier is being actuated as the jaws begin to close against resistance. As the jaws grasp tighter onto the material, the clicking will begin to slow down. This slowing will continue until the material is either cut or the Shear meets full resistance. At full resistance, the clicking will slow dramatically or sometimes stop completely.

## PRESSURE INTENSIFIER (BOOSTER)

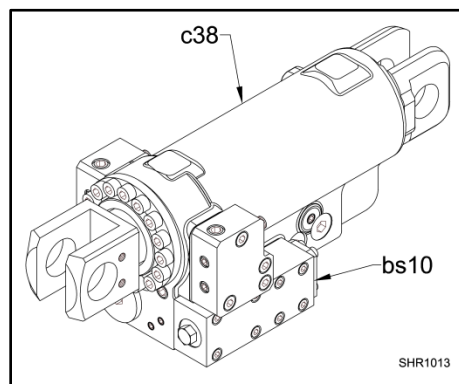

The control valve (bs10) and cylinder/booster assembly (c38) make up the pressure intensifier assembly.

# TROUBLESHOOTING

## RAPID CONTINUOUS CLICKING IS HEARD AND THE MATERIAL IS NOT BEING SHEARED AS EXPECTED

This indicates that the problem is not a relief setting, but it is in the intensifier or the cylinder of the Shear. This requires further investigation by a mechanic/technician, see “**INTENSIFIER CHECKS**” (*clicks – does not slow down*) section on page 94.

## CHECKING BOOSTED PRESSURE

**⚠ WARNING** EXTREMELY HIGH-PRESSURE OIL!

NPK test gauge assembly, **P/N L000-8000** is available to directly check the boosted pressure on all Shears. The pressure intensifier's have three test ports as shown.

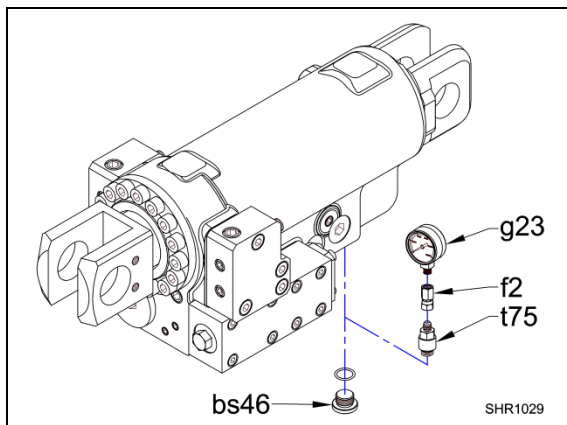

L000-8000 TEST GAUGE ASSEMBLY		
<b>g23</b>	L017-4020	gauge: 0 - 15,000 psi (0 - 1000 bar)
<b>f2</b>	L007-6630	female swivel adapter
<b>t75</b>	K032-6610	male adapter

### PROCEDURE:

1. Remove the plug (bs46) from the test port as shown above and install the male adapter (t75).
2. Install the gauge (g23) into the female swivel adapter (f2). (*Use thread sealant.*)
3. Install the gauge and swivel adapter onto the male adapter. (*No thread sealant required.*)
4. Close the jaws all the way. Pressure will rise to the full boosted pressure of approximately 8,000 psi (552 bar). When the clicking of the booster slows, it is at full intensification, click...click...click...etc., is normal. If the clicking continues rapidly and will not slow down, there may be a problem with the intensifier or the Shear cylinder.
5. Open the jaw all the way. You will now read the carrier relief valve setting. There is no jaw open relief valve on the Shear.

**NOTE:** IF ADDITIONAL ASSISTANCE IS REQUIRED, CALL THE NPK SERVICE DEPARTMENT AT 440-232-7900.

# TROUBLESHOOTING

## SLOW CYCLE SPEED

The specified cycle times of the Shear are controlled by the flow provided by the hydraulic circuit of the carrier. The published cycle times of the Shear are a direct result of the maximum published oil flow; see the “**MODEL SPECIFICATIONS**” section of this instruction manual.

**NOTE:** *If the jaws will not open or close, be sure the open and close shut-off valves are in the “ON” position.*

### Tools and equipment required:

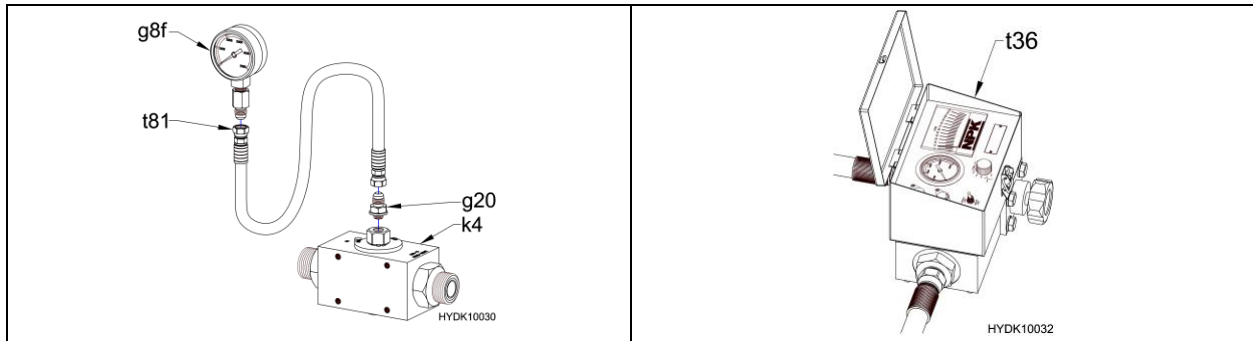

Pressure gauge (g8f): 5000 psi (350 bar).

Test port adapter (g20): to fit #4 SAE female port in NPK shut-off valve (k4).

Test hose (t81): 5000 psi (350 bar) rated.

Loading type hydraulic flow meter (t36): 50 gpm (190 l/m) hydraulic flow capacity.

## TEST PROCEDURE

Install a pressure gauge in the test port of the jaw close circuit (*left shut-off valve as seen from the operator's position*). Fully stroke the Shear cylinder. Measure the attachment operating pressure.

### SLOW CYLINDER SPEED

PROBLEM	CAUSE	CHECK	REMEDY
Slow cylinder speed. Operating pressure is at 2,610 psi (180 bar), but the intensifier does not click.	Carrier flow setting is set too low.	Check flow output of Shear hydraulic circuit at 1000 psi (69 bar).	Adjust carrier flow output to meet NPK specifications.
			Repair or replace the carrier's pump.
	Shear cylinder	Check Shear cylinder packing.	Replace if damaged or worn.

# TROUBLESHOOTING

## TEST PROCEDURE

### SLOW CYLINDER SPEED

PROBLEM	CAUSE	CHECK	REMEDY
Operating Pressure is less than 2,610 psi ( <i>180 bar</i> ).	Carrier hydraulic circuit relief valve.	Measure the carrier circuit relief valve with the pressure to close shut-off valve in the " <b>OFF</b> " position	Adjust or replace the carrier circuit relief valve. The setting for the relief valve must be 500 psi ( <i>35 bar</i> ), minimum, above the Shear operating pressure.
	Shear relief valves	Measure the relief valves with the shut-off valves on the carrier in the " <b>ON</b> " position. Check pressure with the jaws fully open and fully closed.	Setting should be 2,610 psi ( <i>180 bar</i> ).
		Check relief cartridges for tightness.	Tighten the relief valve cartridges.
		Check relief cartridges for mis-adjustment.	Reset to 2,610 psi ( <i>180 bar</i> ). If unable to adjust, replace the cartridge.
		Check the o-rings and backup rings of the relief valve cartridges.	Replace the o-rings and backup rings of both relief valve cartridges.

# TROUBLESHOOTING

## CHECKING THE HYDRAULIC FLOW AT RATED PRESSURE

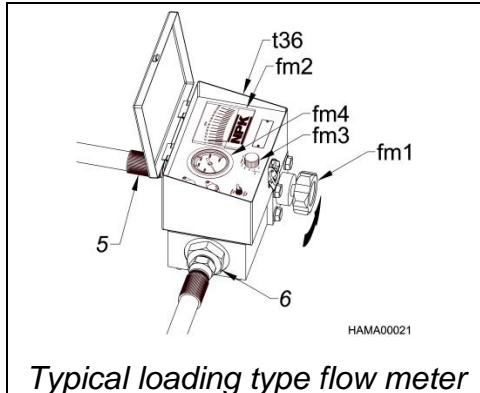

<b>5</b>	out port
<b>6</b>	in port
<b>fm1</b>	load valve
<b>fm2</b>	flow/temperature display
<b>fm3</b>	flow/temperature switch
<b>fm4</b>	pressure gauge

1. Installation of the loading type flow meter.  
Install the flow meter (t36) between the Shear close (m3) and open lines (m4) as shown. Typically, the jaw close line is on the left and the jaw open is on the right of the Shear (looking from the operator's seat).

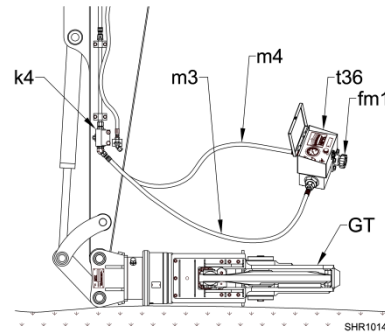

2. Determine the return line pressure (pressure drop).  
Open both shut-off valves (k4) and energize the Shear close switch. Measure the pressure on the flow meter gauge (fm2) with the load valve (fm1) in the fully open position.

3. Determine the circuit relief valve pressure and oil flow.  
NOTE: First, warm the carrier's hydraulic system to operating temperature. Measure the flow and pressure with the loading flow meter (t36). Adjust the load valve (f1) to zero restriction (fully open). Set the engine throttle to the maximum (full) position. Energize the Shear close switch.

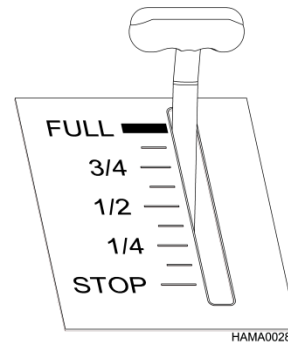
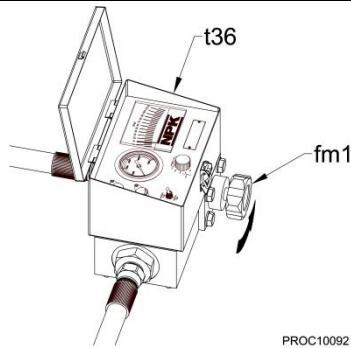

# TROUBLESHOOTING

## CHECKING THE HYDRAULIC FLOW AT RATED PRESSURE

Slowly turn the loading valve knob (fm1) clockwise and record the pressure and flow at regular pressure intervals (pr) on graph paper. Record pressure on one axis of the graph and flow (fl) on the other. This is the circuit flow chart. Refer to the “MODEL SPECIFICATIONS” section of this manual for the correct flow at 1000 psi (70 bar).

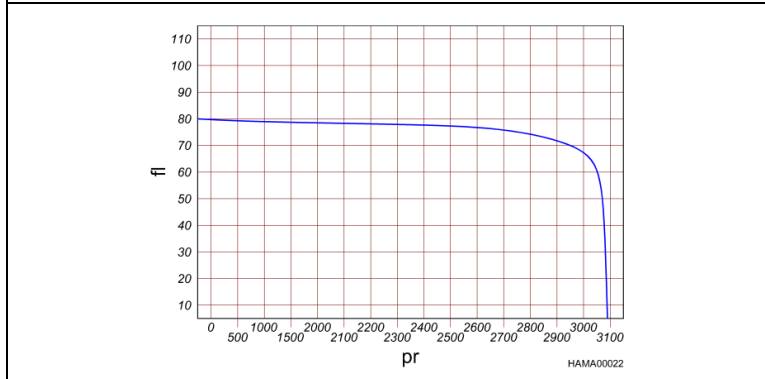

fl	FLOW (gpm)
pr	PRESSURE (psi)

## JAW DRIFT

- Some jaw drift may be experienced depending on the Shear's position.
- Acceptable drift may occur over a number of minutes.
- Rapid drift may indicate a problem with the Shear's cylinder, booster, or swivel manifold. The problem could also be in the carrier's hydraulic circuit.

## TO DETERMINE IF THE JAW DRIFT IS WITH THE SHEAR OR THE CARRIER

1. Remove the hoses (m3 and m4) from the fittings on the outside of the Shear's rotation head and close the shut-off valves on the carrier.
2. Cap (AR) the joint fittings and plug (AS) the hoses. Fitting size is 12 JIC.

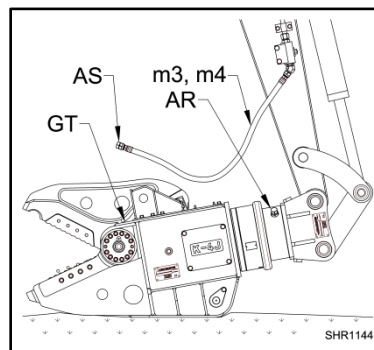

- **IF THE JAW DRIFTS:** The problem is in the cylinder, intensifier pilot checks or internal leakage in the swivel manifold of the Shear (GT).
- **IF NO DRIFT OCCURS:** The problem is in the carrier's main control valve. Contact your carrier dealer.

**NOTE:** Drift due to the main control valve internal leakage may be inherent to the carrier and not repairable.

# TROUBLESHOOTING

---

## ROTATION

The rotation speed is a direct result of the amount of flow (gpm – lpm) supplied by the rotation hydraulic circuit of the carrier. The chart below lists the recommended rotation speed and approximate flow required for your Shear.

MODEL	ROTATION SPEED	APPROXIMATE FLOW		CARRIER RELIEF VALVE SETTING	
	rpm	gpm	(lpm)	psi	(bar)
K3J	10 – 20	2.5 – 5	(9.5 – 19)	3,625	(250)
K4J	10 – 20	2.5 – 5	(9.5 – 19)	3,625	(250)
K7J	14 – 18	3 – 4	(12 – 15)	3,625	(250)

Adjust the rotation flow so that the rpm is within the guidelines shown for the Shear.

Flows are checked at a normal operating pressure of 1000 psi (70 bar). Cross port relief valves set at 2000 psi (138 bar) should be included in the attachment rotation hydraulic circuit. The relief listed in the above chart is only necessary to protect the rotation supply componentry.



*Excessive rotation speed will result in damage to the hydraulic motor, pinion gear, and slewing ring.*



# TROUBLESHOOTING

## MEASURING ROTATION PRESSURES

### ROTATION

PROBLEM	CAUSE	CHECK	REMEDY
Unit will not rotate.	Low or no flow.	Check hydraulic flow. (See <i>Shear rotation flow specifications</i> .)	Adjust rotation hydraulic circuit flow setting.
	Pressure setting of cross-port relief valves (ma4).	Check cross-port relief valve settings. See procedure above.	Adjust the cross-port relief valves on the rotation holding valve (k30). Replace the cross-port relief valves.
	Defective rotation head.	Contact NPK at 440-232-7900.	
Unit will not hold position.	Pressure setting of cross-port relief valves (ma4).	Check cross-port relief valve settings. See procedure above.	Adjust the cross-port relief valves on the rotation holding valve (k30). Replace counterbalance valve.
	Defective rotation head.	Contact NPK at 440-232-7900.	

### IF THE UNIT WILL NOT ROTATE

1. Check the rotation circuit hydraulic flow per the chart above.
  - a. If the flow is within specification, install gauges into the rotation hydraulic circuit hose lines.
  - b. Position the attachment so it will not rotate.
  - c. Attempt to rotate the unit in both directions. Each gauge should read 2000 psi (138 bar).
  - d. If 2000 psi (138 bar) is not achieved, adjust the cross-port relief valves (ma4) in the rotation valve (k30) of the attachment rotation hydraulic circuit.
  - e. If adjustment is not possible, call the NPK Service Department at 440-232-7900.
2. Check rotation head. (*Contact NPK for assistance.*)

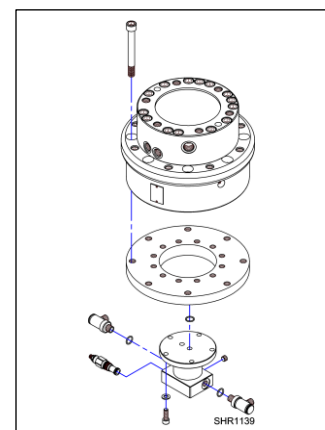
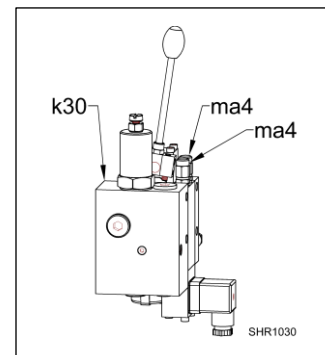

### UNIT WILL NOT HOLD POSITION

Follow steps 1a through 1e above.

# KEYWORDS FOR COMMON K-SERIES SHEAR COMPONENTS

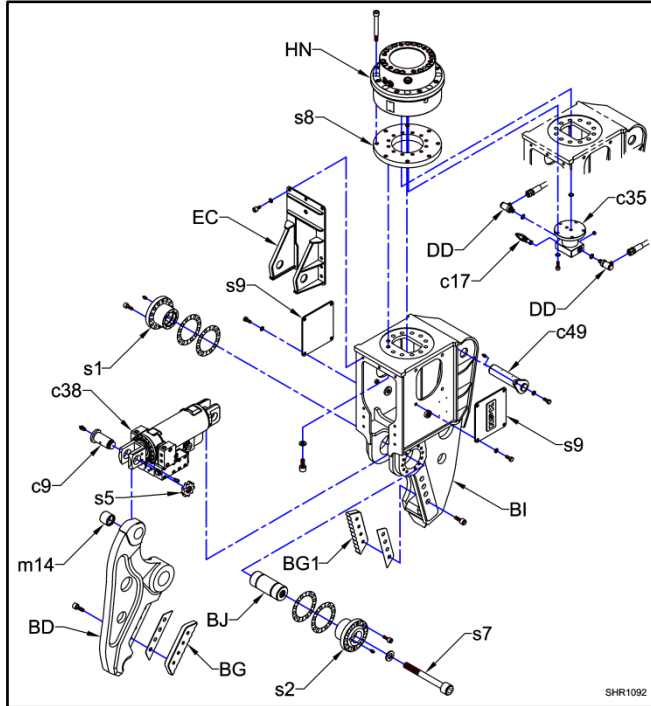

BD	MALE JAW
BG	PRIMARY BLADE
BG1	SECONDARY BLADE
BI	MAIN FRAME
BJ	PIN
c 9	JAW PIN
c17	RELIEF VALVE CARTRIDGE (close)
c35	MANIFOLD BLOCK
c38	CYLINDER/BOOSTER ASSEMBLY
c49	CYLINDER PIN
DD	SWIVEL ADAPTER ASSEMBLY
EC	COVER PLATE
HN	ROTATION HEAD
m14	BUSHING
s1	FLANGE
s2	FLANGE
s5	NUT
s7	PIVOT PIN BOLT
s8	MOUNTING PLATE
s9	COVER PLATE

# KEYWORDS FOR COMMON K-SERIES BOOSTER/CYLINDER COMPONENTS

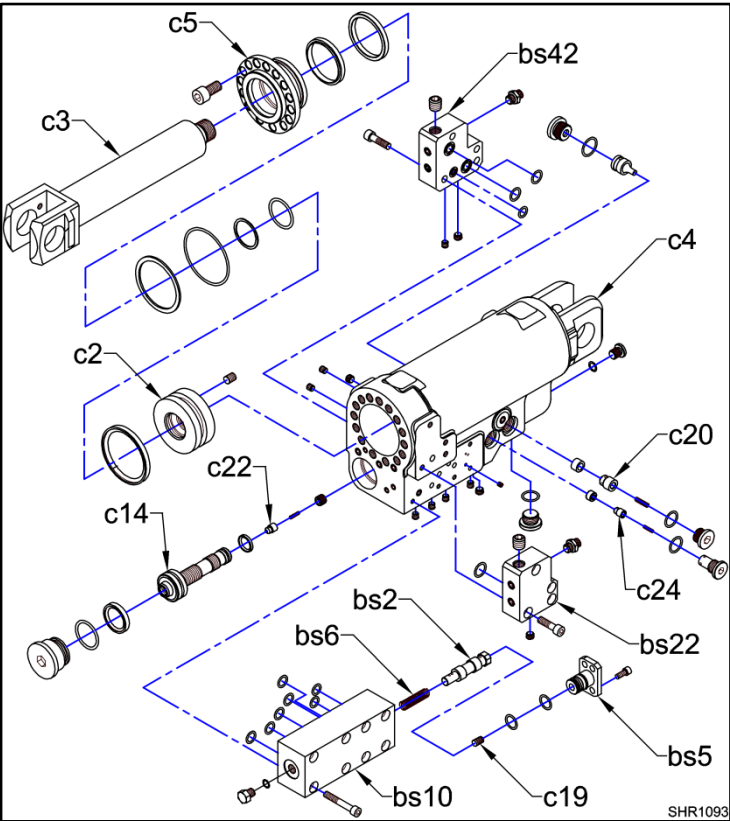

bs 2	MAIN VALVE SPOOL
bs 5	CONTROL VALVE CAP
bs 6	SPRING
bs 10	CONTROL VALVE BODY
bs 22	INLET BLOCK
bs 42	RETURN BLOCK
c 1	CYLINDER ROD NUT
c 2	PISTON
c 3	CYLINDER ROD
c 4	CYLINDER MAIN BARREL
c 5	CYLINDER END CAP
c 14	BOOSTER PISTON
c 19	PLUNGER
c 20	PILOT CHECK VALVE ASSEMBLY
c 22	CHECK VALVE
c 24	CHECK VALVE

# FASTENER TORQUE SPECIFICATIONS

These torque charts are to be used with the specific “K” Series shear parts manual for the unit being repaired.

All fasteners will be used with lube or medium strength thread adhesive. Bolts must have their threads wire brushed or cleaned with a thread die, then cleaned with solvent and finally cleaned with compressed air. Threaded holes must be cleaned with a thread tap, solvent and also with compressed air.

Use a common chassis or wheel bearing grease on fasteners listed as lubed. Grease the threads of the bolt and the contact surface under the bolt head. Grease the contact surface of nuts.

Use a few drops of medium strength thread adhesive on the threads of fasteners listed as torqued with adhesive.

Do not use anti-seize compound on any fasteners, unless otherwise noted.

## FASTENER TORQUE CHART - MAIN FRAME ASSEMBLY

BOLT LOCATION	MODEL	BOLT SIZE	BOLT TORQUE		ADHESIVE OR LUBED
			ft. lb.	(Nm)	
CYLINDER ROD END PIVOT PIN KEEPER	K3JR	M8 - 1.25	25	(35)	LUBED
	K4JR	M8 - 1.25	25	(35)	LUBED
	K7JR	M10 - 1.5	50	(70)	LUBED
CYL. BARREL END PIVOT PIN KEEPER	K3JR	M14 - 2.0	130	(180)	LUBED
	K4JR	M10 - 1.5	45	(60)	LUBED
	K7JR	M10 - 1.5	45	(60)	LUBED
JAW PIVOT PIN	K3JR	M24 - 2	405	(550)	LUBED
	K4JR	M27 - 2	480	(650)	LUBED
	K7JR	M36 - 2.0	N/A	N/A	LUBED
JAW PIVOT FLANGE	K3JR	M10 - 1.5	50	(70)	LUBED
	K4JR	M12 - 1.75	95	(130)	LUBED
	K7JR	M12 - 1.75	95	(130)	LUBED
CUTTING BLADE	K3JR	M12 - 1.75	95	(130)	ADHESIVE
	K4JR	M14 - 2.0	150	(200)	ADHESIVE
	K7JR	M16 - 2.0	260	(350)	ADHESIVE
FRAME COVER	K3JR	M10 - 1.5	45	(60)	LUBED
	K4JR	M10 - 1.5	45	(60)	LUBED
	K7JR	M10 - 1.5	45	(60)	LUBED
COVER	K3JR	M10 - 1.5	45	(60)	LUBED
	K4JR	M10 - 1.5	45	(60)	LUBED
	K7JR	M10 - 1.5	50	(70)	LUBED

# FASTENER TORQUE SPECIFICATIONS

## FASTENER TORQUE CHART - BOOSTER/CYLINDER ASSEMBLY

BOLT LOCATION	MODEL	BOLT SIZE	BOLT TORQUE		ADHESIVE OR LUBED
			ft. lb.	(Nm)	
CYLINDER END CAP	K3JR	M12 - 1.75	65	(90)	LUBED
	K4JR	M14 - 2.0	145	(200)	LUBED
	K7JR	M16 - 2.0	260	(350)	LUBED
CYLINDER PISTON SET SCREW	K3JR	M10 - 1.5	10	(14)	ADHESIVE
	K4JR	M10 - 1.5	10	(14)	ADHESIVE
	K7JR	M12 - 1.75	15	(20)	ADHESIVE
INLET AND RETURN BLOCKS	K3JR	M10 - 1.5	50	(70)	ADHESIVE
	K4JR	M10 - 1.5	50	(70)	ADHESIVE
	K7JR	M10 - 1.5	50	(70)	ADHESIVE
CONTROL VALVE	K3JR	M8 - 1.25	25	(35)	ADHESIVE
	K4JR	M8 - 1.25	25	(35)	ADHESIVE
	K7JR	M8 - 1.25	25	(35)	ADHESIVE
CONTROL VALVE PLUNGER BUSHING	K3JR	M8 - 1.25	25	(35)	ADHESIVE
	K4JR	M8 - 1.25	25	(35)	ADHESIVE
	K7JR	M8 - 1.25	25	(35)	ADHESIVE

## FASTENER TORQUE CHART - ROTATION COMPONENTS

BOLT LOCATION	MODEL	BOLT SIZE	BOLT TORQUE		ADHESIVE OR LUBED
			ft. lb.	(Nm)	
ROTATION HEAD	K3JR	M16	260	(350)	ADHESIVE
	K4JR	M16	260	(350)	ADHESIVE
MOUNTING PLATE	K3JR	M20	405	(550)	ADHESIVE
	K4JR	M20	405	(550)	ADHESIVE
ADAPTER RING	K3JR	M14	150	(200)	ADHESIVE
	K4JR	M14	150	(200)	ADHESIVE

# FASTENER TORQUE SPECIFICATIONS

---

## FASTENER TORQUE CHART - ROTATION COMPONENTS

BOLT LOCATION	MODEL	BOLT SIZE	BOLT TORQUE		ADHESIVE OR LUBED
			ft. lb.	(Nm)	
FRAME TO ADAPTER RING (CAP SCREW)	K7JR	M16	260	(350)	ADHESIVE
BEARING TO ADAPTER RING (CAP SCREW)	K7JR	M12	95	(130)	ADHESIVE
BEARING TO SWIVEL TOP (CAP SCREW)	K7JR	M12	95	(130)	ADHESIVE
MOUNTING PLATE	K7JR	M20	480	(650)	ADHESIVE

# WARRANTY STATEMENTS

"Use Genuine NPK Parts" 7/16

## **NPK** WARRANTY

### BOOM MOUNTED MATERIAL PROCESSORS, CONCRETE CRUSHERS, AND SHEARS

APPLICATION FOR WARRANTY MUST BE MADE WITHIN 30 WORKING DAYS OF FAILURE / REPAIR.

#### BASE WARRANTY (6 months or 600 hours)

NPK CONSTRUCTION EQUIPMENT, INC. ("NPK") warrants that Boom Mounted Material Processors, Concrete Crushers, and Shears sold by NPK will be free from defects in material or workmanship for a period of six (6) months or 600 operating hours, whichever occurs first, starting from the date of delivery to the first user.

#### THIS WARRANTY DOES NOT APPLY TO:

- HYDRAULIC and MOUNTING INSTALLATION KIT PARTS, HOSES, or REPLACEMENT PARTS, which are covered by other warranties.

#### NPK RESPONSIBILITY

NPK will, at its option, repair or replace with a new or reconditioned part, any warranted part that fails by reason of defective material or workmanship, free of charge delivered at a place of business of an NPK Dealer. Note: Parts replaced under warranty become the property of NPK.

During the six (6) month or 600 hour BASE WARRANTY period, NPK will pay the cost of labor at 75% of the posted shop rate that is necessary to install any repaired or replacement part during normal working hours. Overtime rates and travel expenses will not be reimbursed.

#### USER RESPONSIBILITY

- **Photos must accompany all warranties submitted to NPK. These photos can be 35mm, polaroid, or digital.**
- The installer, user, operator, repairer, assumes responsibility to read, understand and comply with NPK's written INSTALLATION, OPERATOR, SERVICE and WELDING INSTRUCTIONS.
- Returning Warranty Registration to NPK at the time of installation.
- All costs associated with transporting the boom mounted material processor, concrete crusher, or shear or equipment to which the boom mounted material processor, concrete crusher, or shear is installed, to an authorized NPK Dealer or other authorized location. NPK is not responsible for any expense incurred in field repair.
- Supplying a hydraulic oil sample from the carrier machine upon request by NPK.

#### THESE WARRANTIES DO NOT COVER FAILURES RESULTING FROM:

- Installation, alteration, operation, maintenance, repair or storage which NPK judges improper.
- Not performing DAILY VISUAL INSPECTIONS as specified in the NPK MANUALS.
- Exceeding the steel cutter wear limit.
- Failures resulting from jaw / tooth wear that is beyond the limits as specified in the NPK Service or Instruction Manuals.
- Not following the NPK recommended welding procedure.
- Operation after discovery of defective or worn parts.
- Unreasonable delay in making a repair after being notified of a potential product problem.

#### THESE WARRANTIES SPECIFICALLY EXCLUDE:

- Installations not approved by NPK.
- Hardface welding to build up wear surfaces.
- Replacement due to wear, e.g. crusher jaws and steel cutter.
- Repairs by other than an authorized NPK Dealer.
- Any attachment or alteration to the crusher jaws.
- Use of parts not sold by NPK. **THE USE OF "WILL FIT" PARTS WILL VOID ALL NPK WARRANTIES.**
- Labor charges that are deemed excessive by NPK.
- Parts shipping charges in excess of those which are usual and customary. (Air freight, unless pre-approved, will not be covered.)
- Duties, brokerage fees, and local taxes.

WARRANTY REPAIRS DO NOT EXTEND THE STANDARD WARRANTY PERIOD.

#### LIMITATIONS AND EXCLUSIONS

Violation of any federal, provincial, state or local laws, ordinances, rules or regulations, or removal or alteration of product serial numbers void NPK's written product warranties. **Application for warranty must be made within 30 days of failure / repair.**

**THIS PRODUCT MUST BE USED IN A SAFE AND LAWFUL MANNER IN COMPLIANCE WITH APPLICABLE OSHA REGULATIONS.**

The written product warranties made by NPK set forth NPK's only obligations with respect to any claims of failure, defects or deficiencies in products sold by NPK. **NPK MAKES NO OTHER WARRANTIES OR REPRESENTATIONS WHATSOEVER, EXPRESS OR IMPLIED, OF THE QUALITY, PERFORMANCE, DURABILITY, MATERIALS, WORKMANSHIP, SUITABILITY, CONDITION, DESIGN OR UTILITY OF PRODUCTS SOLD BY NPK, INCLUDING, WITHOUT LIMITATION, IMPLIED WARRANTIES OF MERCHANTABILITY AND FITNESS, ALL SUCH OTHER WARRANTIES AND REPRESENTATIONS BEING HEREBY EXPRESSLY EXCLUDED. NPK SHALL NOT BE LIABLE FOR SPECIAL, INCIDENTAL OR CONSEQUENTIAL DAMAGES, INCLUDING, WITHOUT LIMITATION, COSTS, LOSSES OR LIABILITIES ON ACCOUNT OF DELAY OR DOWNTIME.**

#### DISCLAIMER REGARDING OTHER REPRESENTATIONS OR WARRANTIES

No person is authorized to grant any other warranties or to assume any other liability on NPK's behalf unless made or assumed in writing by an officer of NPK. No person is authorized to grant any warranties or to assume any liabilities on the seller's behalf unless made or assumed in writing by the seller.

Internet: [www.npkce.com](http://www.npkce.com)

As used in this warranty the term NPK means NPK CONSTRUCTION EQUIPMENT, INC., WALTON HILLS, OHIO, U.S.A.

# WARRANTY STATEMENTS

"Use Genuine NPK Parts" 6/08

## **NPK** WARRANTY REPLACEMENT PARTS

**APPLICATION FOR WARRANTY MUST BE MADE WITHIN 30 WORKING DAYS OF FAILURE / REPAIR.**

### **REPLACEMENT PARTS WARRANTY (90 days)**

NPK CONSTRUCTION EQUIPMENT, INC. ("NPK") warrants that new Replacement Parts sold by NPK will be free from defects in material or workmanship for a period of ninety (90) days, starting from the date of installation. NPK Replacement Parts Warranty **does not** cover labor or travel expenses. Note: Unexpired New Product Warranty has priority over Replacement Parts Warranty.

### **THIS WARRANTY DOES NOT APPLY TO:**

- Wear items such as upper and lower tool bushings, impact ring, retaining bars and pins.
- Tools (covered under separate Tool Warranty).

### **NPK RESPONSIBILITY**

NPK will, at its option, repair or replace with a new or reconditioned part, any warranted part that fails by reason of defective material or workmanship, free of charge delivered at a place of business of an NPK Dealer. Note: Parts replaced under warranty become the property of NPK.

### **USER RESPONSIBILITY**

- **Photos must accompany all warranties submitted to NPK. These photos can be 35mm, polaroid, or digital.**
- The installer, user, operator, repairer, assumes responsibility to read, understand and comply with NPK's written INSTALLATION, OPERATOR and SERVICE INSTRUCTIONS.
- All labor costs.
- Any expense incurred by field repair.
- Supplying a hydraulic oil sample from the carrier machine upon request by NPK.

### **THESE WARRANTIES DO NOT COVER FAILURES RESULTING FROM:**

- Installation, alteration, operation, maintenance, repair or storage which NPK judges improper.
- Not performing DAILY VISUAL INSPECTIONS and/or RETIGHTENING of fasteners after initial 20 operating hours after repair.
- Exceeding the tool and/or tool bushing wear limit.
- Underwater operation.
- Operation after discovery of defective or worn parts.
- Unreasonable delay in making a repair after being notified of a potential product problem.

### **THESE WARRANTIES SPECIFICALLY EXCLUDE:**

- Installations not approved by NPK.
- Replacement due to normal wear.
- Use of parts not sold by NPK. **THE USE OF "WILL FIT" PARTS WILL VOID ALL NPK WARRANTIES.**
- Parts shipping charges in excess of those which are usual and customary. (Air freight, unless pre-approved, will not be covered.)
- Duties, brokerage fees, and local taxes.

**WARRANTY REPAIRS DO NOT EXTEND THE STANDARD WARRANTY PERIOD.**

### **LIMITATIONS AND EXCLUSIONS**

Violation of any federal, provincial, state or local laws, ordinances, rules or regulations, or removal or alteration of product serial numbers void NPK's written product warranties. **Application for warranty must be made within 30 days of failure / repair.**

**THIS PRODUCT MUST BE USED IN A SAFE AND LAWFUL MANNER IN COMPLIANCE WITH APPLICABLE OSHA REGULATIONS.**

The written product warranties made by NPK set forth NPK's only obligations with respect to any claims of failure, defects or deficiencies in products sold by NPK. **NPK MAKES NO OTHER WARRANTIES OR REPRESENTATIONS WHATSOEVER, EXPRESS OR IMPLIED, OF THE QUALITY, PERFORMANCE, DURABILITY, MATERIALS, WORKMANSHIP, SUITABILITY, CONDITION, DESIGN OR UTILITY OF PRODUCTS SOLD BY NPK, INCLUDING, WITHOUT LIMITATION, IMPLIED WARRANTIES OF MERCHANTABILITY AND FITNESS, ALL SUCH OTHER WARRANTIES AND REPRESENTATIONS BEING HEREBY EXPRESSLY EXCLUDED. NPK SHALL NOT BE LIABLE FOR SPECIAL, INCIDENTAL OR CONSEQUENTIAL DAMAGES, INCLUDING, WITHOUT LIMITATION, COSTS, LOSSES OR LIABILITIES ON ACCOUNT OF DELAY OR DOWNTIME.**

### **DISCLAIMER REGARDING OTHER REPRESENTATIONS OR WARRANTIES**

No person is authorized to grant any other warranties or to assume any other liability on NPK's behalf unless made or assumed in writing by an officer of NPK. No person is authorized to grant any warranties or to assume any liabilities on the seller's behalf unless made or assumed in writing by the seller.

Internet: [www.npkce.com](http://www.npkce.com)

As used in this warranty the term NPK means NPK CONSTRUCTION EQUIPMENT, INC., WALTON HILLS, OHIO, U.S.A.





---

**NPK**

7550 INDEPENDENCE DRIVE WALTON HILLS, OHIO 44146

PHONE: 440-232-7900

FAX: 440-232-6294

---